



Republic of the Philippines
Benguet State University
 2601 La Trinidad, Benguet
 www.bsu.edu.ph
 Telefax No. (074) 661-1839;

REQUEST FOR QUOTATION (RFQ)
(ALL ENTRIES ARE MANDATORY)

Name of Owner/ Corporation/ Cooperative/	QUOTATION NO. <u>618</u>
Name of Business :	DATE: <u>May 17, 2024</u>
Address:	P.R. NO. : <u>2024-01-131</u>
Email address: _____ Telephone No. _____	ABC: <u>Php. 250,000.00</u>
	FUND SOURCE: <u>GAA-FLR 2023</u>

The Benguet State University through its Bids and Awards Committee will undertake ^{NP-STP} for the item/s listed below under the following terms and conditions:

- All entries must be written legibly and accurately.
- Delivery period is within 15 calendar days.
- Warranty period shall be for a minimum of three months, in case of expendable supplies, and a minimum of one year in case of non- expendable supplies from date of acceptance by the University.
- Price validity shall be for a period of 30 calendar days.
- Compliance with specifications: Kindly specify in the column provided below whether the offer fully complies with the specifications or a counter offer.
- Deadline of submission of quotation is on or before 5:00 pm of May 24, 2024 **Offers may be submitted in sealed or open quotation in person, or through facsimile (074-661-1839) or email (procurement@bsu.edu.ph)**
- The item/s shall be procured by: / a) line item; _____ b) lot; _____ c) sub-lot
- Business Permit Number : _____, date of issue: _____, place of issue: _____, (If renewal of Business Permit is still on process, please indicate OR No: _____, date of OR : _____ for the payment of renewal).
- PhilGEPS Registration Number: _____

SAMUEL S. POLIDEN
 Chairperson, BAC (Goods & Services)

College/Dept./ Office: OVPAA/ College of Medicine

Item No.	Qty	Unit	Item	Technical Specifications (Brand and Model)		ABC	Unit Cost	Total Cost
				COMPLY	COUNTER OFFER			
1	10	unit	FACULTY PLATFORM: 0.90m x 1.20m x 0.20m H; Fiber cement board; with carpet roll covering; finish; <u>see attached design</u>			250,000.00		
TOTAL						250,000.00		

Counter offers:
 Delivery Period: _____
 Warranty: _____
 Price Validity: _____

We hereby submit our quotations, accept the general conditions for the above items and be bound by our offer.

 Signature over Printed Name _____
 Date and Time of Receipt of RFQ

* Not a ground for disqualification for failure to indicate but required as a condition for award.

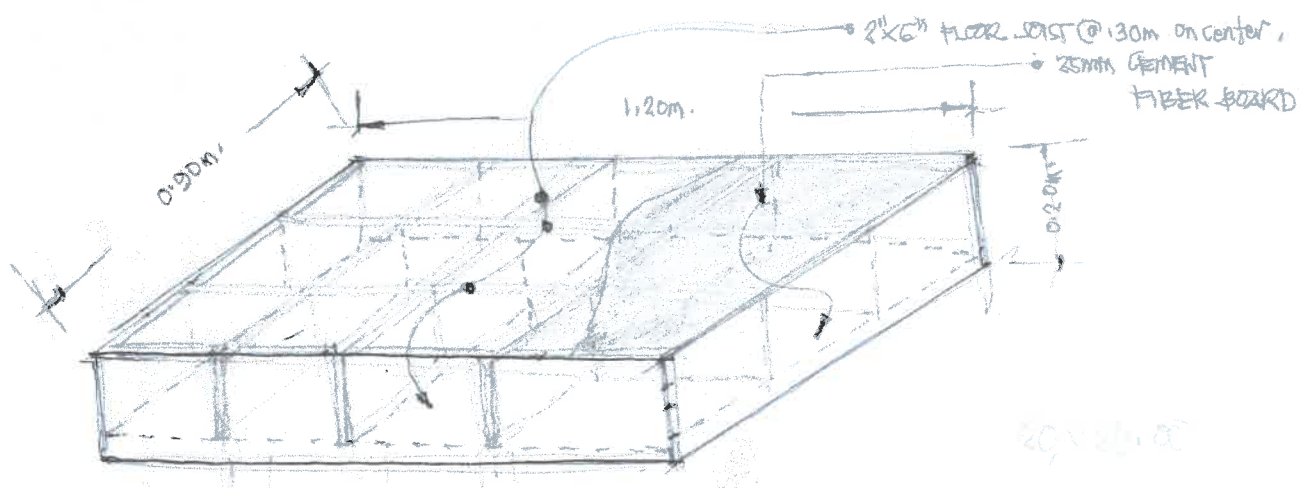

10-UNITS - (0.90m x 1.20m x 0.20m)