



Republic of the Philippines
Benguet State University
 2601 La Trinidad, Benguet
 www.bsu.edu.ph

REQUEST FOR QUOTATION (RFQ)
(ALL ENTRIES ARE MANDATORY)

Name of Owner/ Corporation/ Cooperative/ Agency: _____
 Name of Business : _____
 Address: _____
 Email address: _____ Telephone No. _____

QUOTATION NO. 994
 DATE: AUG 12 2024
 P.R. NO. : 2024-05-889
 ABC: Php. 140,000.00
 FUND SOURCE: JP

The Benguet State University through its Bids and Awards Committee will undertake NP-VVP for the item/s listed below under the following terms and conditions:

- All entries must be written legibly and accurately.
- Delivery period is within 30 calendar days.
- Warranty period shall be for a minimum of three months, in case of expendable supplies, and a minimum of one year in case of non- expendable supplies from date of acceptance by the University.
- Price validity shall be for a period of 30 calendar days.
- Compliance with specifications: Kindly specify in the column provided below whether the offer fully complies with the specifications or a counter offer.
- Deadline of submission of quotation is on or before 5:00 PM of Aug. 19 2024. Offers may be submitted in sealed or open quotation in person, or through facsimile (074-661-1839) or email (procurement@bsu.edu.ph)
- The item/s shall be procured by: a) line item; b) lot; c) sub-lot
 Business Permit Number : _____, date of issue: _____, place of issue: _____
- _____,(If renewal of Business Permit is still on process, please indicate OR No: _____, date of OR : _____ for the payment of renewal).
- * PhilGEPS Registration Number: _____

SAMUEL S. POLIDEN
 Chairperson, BAC (Goods & Services)

College/Dept./Office: **BAPTC**

Item No.	Qty	Unit	Item	Technical Specifications		ABC	Unit Cost	Total Cost
				COMPLY	COUNTER OFFER			
<i>supply and delivery of furnitures</i>								
1	2	set	Wooden sofa set; two (2) long with four seating capacity each; 6 single seater with foam and 1 center table (design attached) foam: 6" thick, with covers, fitted to chairs			P 140,000.00		
TOTAL							140,000.00	

Counter offers:
 Delivery Period: _____
 Warranty: _____
 Price Validity: _____

We hereby submit our quotations, accept the general conditions for the above items and be bound by our offer.

 Signature over Printed Name

 Date and Time of Receipt of RFQ

* Not a ground for disqualification for failure to indicate but required as a condition for award. Revised: 9/19/2022

CENTER TABLE

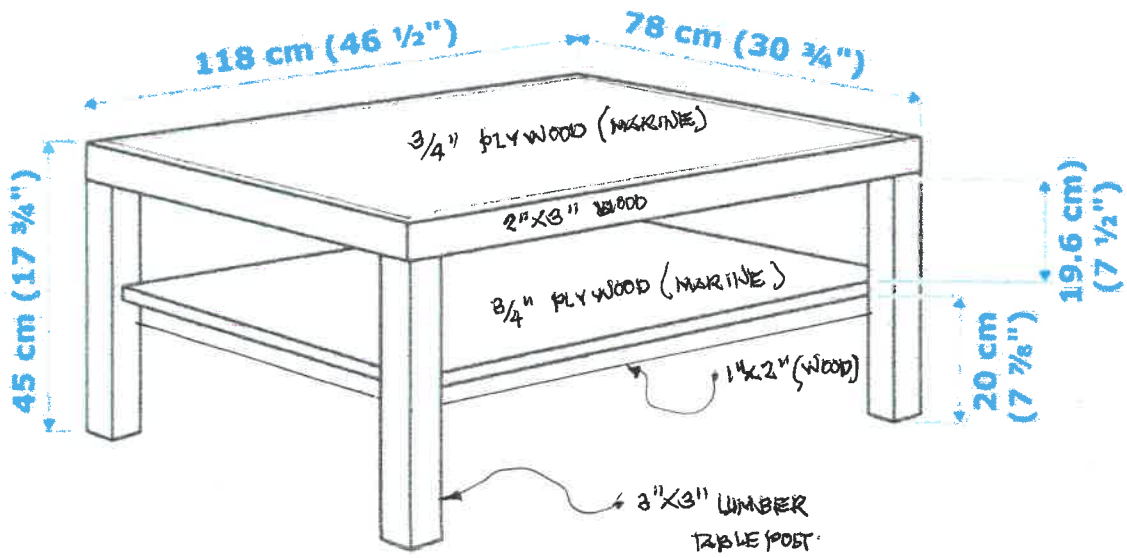

VARNISH FINISHED

Sofa

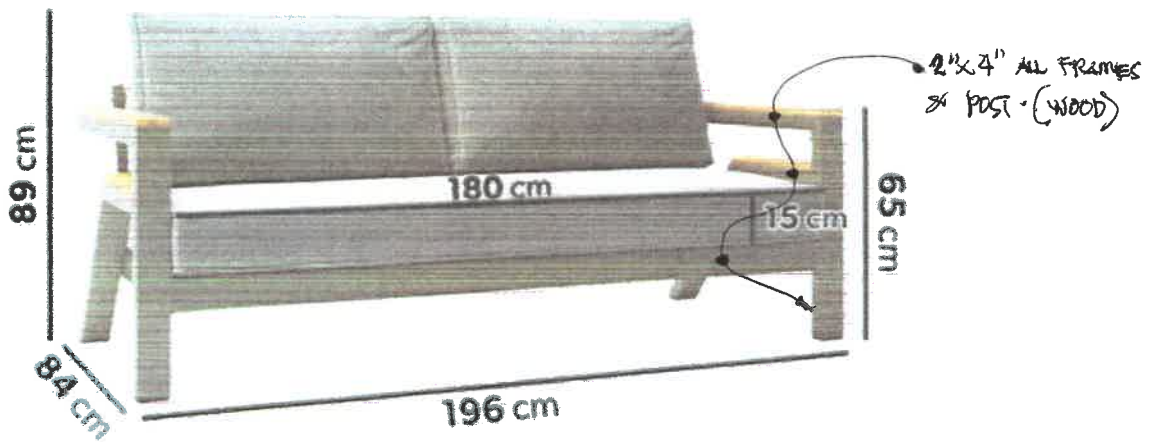

VARNISH FINISHED.