

PHILIPPINE BIDDING DOCUMENTS



Republic of the Philippines
Benguet State University
La Trinidad, 2601 Benguet
TeleFax (074) 661-1839
www.bsu.edu.ph



IB 2024-26A– REPAIR OF THE POULTRY PROJECT OFFICE BUILDING (SECOND INVITATION TO BID)



Project Location	BSU La Trinidad Campus, Km 5, Balili, La Trinidad, Benguet
Brief Description	The project is a renovation of the One-storey office building. The scope of work includes earthworks, structural works, plumbing works, electrical works and finishing works.
Approved Budget for the Contract (ABC)	PhP. 2,200,000.00
Contract Duration	85 calendar days
Amount of Bidding Documents	Php. 3,000.00

Preface

These Philippine Bidding Documents (PBDs) for the procurement of Infrastructure Projects (hereinafter referred to also as the “Works”) through Competitive Bidding have been prepared by the Government of the Philippines for use by all branches, agencies, departments, bureaus, offices, or instrumentalities of the government, including government-owned and/or -controlled corporations, government financial institutions, state universities and colleges, local government units, and autonomous regional government. The procedures and practices presented in this document have been developed through broad experience, and are for mandatory use in projects that are financed in whole or in part by the Government of the Philippines or any foreign government/foreign or international financing institution in accordance with the provisions of the 2016 revised Implementing Rules and Regulations (IRR) of Republic Act (RA) No. 9184.

The PBDs are intended as a model for admeasurements (unit prices or unit rates in a bill of quantities) types of contract, which are the most common in Works contracting.

The Bidding Documents shall clearly and adequately define, among others: (i) the objectives, scope, and expected outputs and/or results of the proposed contract; (ii) the eligibility requirements of Bidders; (iii) the expected contract duration; and (iv) the obligations, duties, and/or functions of the winning Bidder.

Care should be taken to check the relevance of the provisions of the PBDs against the requirements of the specific Works to be procured. If duplication of a subject is inevitable in other sections of the document prepared by the Procuring Entity, care must be exercised to avoid contradictions between clauses dealing with the same matter.

Moreover, each section is prepared with notes intended only as information for the Procuring Entity or the person drafting the Bidding Documents. They shall not be included in the final documents. The following general directions should be observed when using the documents:

- a. All the documents listed in the Table of Contents are normally required for the procurement of Infrastructure Projects. However, they should be adapted as necessary to the circumstances of the particular Project.
- b. Specific details, such as the “*name of the Procuring Entity*” and “*address for bid submission*,” should be furnished in the Instructions to Bidders, Bid Data Sheet, and Special Conditions of Contract. The final documents should contain neither blank spaces nor options.
- c. This Preface and the footnotes or notes in italics included in the Invitation to Bid, BDS, General Conditions of Contract, Special Conditions of Contract, Specifications, Drawings, and Bill of Quantities are not part of the text of the final document, although they contain instructions that the Procuring Entity should strictly follow.
- d. The cover should be modified as required to identify the Bidding Documents as to the names of the Project, Contract, and Procuring Entity, in addition to date of issue.

- e. Modifications for specific Procurement Project details should be provided in the Special Conditions of Contract as amendments to the Conditions of Contract. For easy completion, whenever reference has to be made to specific clauses in the Bid Data Sheet or Special Conditions of Contract, these terms shall be printed in bold typeface on Sections I (Instructions to Bidders) and III (General Conditions of Contract), respectively.
- f. For guidelines on the use of Bidding Forms and the procurement of Foreign-Assisted Projects, these will be covered by a separate issuance of the Government Procurement Policy Board.

TABLE OF CONTENTS

Glossary of Terms, Abbreviations, and Acronyms	5
Section I. Invitation to Bid	7
Section II. Instructions to Bidders	10
1. Scope of Bid.....	11
2. Funding Information	11
3. Bidding Requirements.....	11
4. Corrupt, Fraudulent, Collusive, Coercive, and Obstructive Practices.....	11
5. Eligible Bidders	11
6. Origin of Associated Goods	12
7. Subcontracts.....	12
8. Pre-Bid Conference	12
9. Clarification and Amendment of Bidding Documents	12
10. Documents Comprising the Bid: Eligibility and Technical Components	12
11. Documents Comprising the Bid: Financial Component	13
12. Alternative Bids	13
13. Bid Prices	13
14. Bid and Payment Currencies	13
15. Bid Security.....	14
16. Sealing and Marking of Bids	14
17. Deadline for Submission of Bids	14
18. Opening and Preliminary Examination of Bids	14
19. Detailed Evaluation and Comparison of Bids.....	14
20. Post Qualification	15
21. Signing of the Contract.....	15
Section III. Bid Data Sheet.....	16
Section IV. General Conditions of Contract	19
1. Scope of Contract.....	20
2. Sectional Completion of Works	20
3. Possession of Site	20
4. The Contractor’s Obligations	20
5. Performance Security.....	20

6.	Site Investigation Reports	21
7.	Warranty	21
8.	Liability of the Contractor	21
9.	Termination for Other Causes.....	21
10.	Dayworks.....	21
11.	Program of Work.....	22
12.	Instructions, Inspections and Audits.....	22
13.	Advance Payment	22
14.	Progress Payments.....	22
15.	Operating and Maintenance Manuals	22
	Section V. Special Conditions of Contract	23
	Section VI. Specifications	25
	Section VII. Drawings.....	58
	Section VIII. Bill of Quantities	59
	Section IX. Checklist of Technical and Financial Documents.....	61

Glossary of Terms, Abbreviations, and Acronyms

ABC – Approved Budget for the Contract.

ARCC – Allowable Range of Contract Cost.

BAC – Bids and Awards Committee.

Bid – A signed offer or proposal to undertake a contract submitted by a bidder in response to and in consonance with the requirements of the bidding documents. Also referred to as *Proposal* and *Tender*. (2016 revised IRR, Section 5[c])

Bidder – Refers to a contractor, manufacturer, supplier, distributor and/or consultant who submits a bid in response to the requirements of the Bidding Documents. (2016 revised IRR, Section 5[d])

Bidding Documents – The documents issued by the Procuring Entity as the bases for bids, furnishing all information necessary for a prospective bidder to prepare a bid for the Goods, Infrastructure Projects, and/or Consulting Services required by the Procuring Entity. (2016 revised IRR, Section 5[e])

BIR – Bureau of Internal Revenue.

BSP – Bangko Sentral ng Pilipinas.

CDA – Cooperative Development Authority.

Consulting Services – Refer to services for Infrastructure Projects and other types of projects or activities of the GOP requiring adequate external technical and professional expertise that are beyond the capability and/or capacity of the GOP to undertake such as, but not limited to: (i) advisory and review services; (ii) pre-investment or feasibility studies; (iii) design; (iv) construction supervision; (v) management and related services; and (vi) other technical services or special studies. (2016 revised IRR, Section 5[i])

Contract – Refers to the agreement entered into between the Procuring Entity and the Supplier or Manufacturer or Distributor or Service Provider for procurement of Goods and Services; Contractor for Procurement of Infrastructure Projects; or Consultant or Consulting Firm for Procurement of Consulting Services; as the case may be, as recorded in the Contract Form signed by the parties, including all attachments and appendices thereto and all documents incorporated by reference therein.

Contractor – is a natural or juridical entity whose proposal was accepted by the Procuring Entity and to whom the Contract to execute the Work was awarded. Contractor as used in these Bidding Documents may likewise refer to a supplier, distributor, manufacturer, or consultant.

CPI – Consumer Price Index.

DOLE – Department of Labor and Employment.

DTI – Department of Trade and Industry.

Foreign-funded Procurement or Foreign-Assisted Project – Refers to procurement whose funding source is from a foreign government, foreign or international financing institution as specified in the Treaty or International or Executive Agreement. (2016 revised IRR, Section 5[b]).

GFI – Government Financial Institution.

GOCC – Government-owned and/or –controlled corporation.

Goods – Refer to all items, supplies, materials and general support services, except Consulting Services and Infrastructure Projects, which may be needed in the transaction of public businesses or in the pursuit of any government undertaking, project or activity, whether in the nature of equipment, furniture, stationery, materials for construction, or personal property of any kind, including non-personal or contractual services such as the repair and maintenance of equipment and furniture, as well as trucking, hauling, janitorial, security, and related or analogous services, as well as procurement of materials and supplies provided by the Procuring Entity for such services. The term “related” or “analogous services” shall include, but is not limited to, lease or purchase of office space, media advertisements, health maintenance services, and other services essential to the operation of the Procuring Entity. (2016 revised IRR, Section 5[r])

GOP – Government of the Philippines.

Infrastructure Projects – Include the construction, improvement, rehabilitation, demolition, repair, restoration or maintenance of roads and bridges, railways, airports, seaports, communication facilities, civil works components of information technology projects, irrigation, flood control and drainage, water supply, sanitation, sewerage and solid waste management systems, shore protection, energy/power and electrification facilities, national buildings, school buildings, hospital buildings, and other related construction projects of the government. Also referred to as *civil works or works*. (2016 revised IRR, Section 5[u])

LGUs – Local Government Units.

NFCC – Net Financial Contracting Capacity.

NGA – National Government Agency.

PCAB – Philippine Contractors Accreditation Board.

PhilGEPS - Philippine Government Electronic Procurement System.

Procurement Project – refers to a specific or identified procurement covering goods, infrastructure project or consulting services. A Procurement Project shall be described, detailed, and scheduled in the Project Procurement Management Plan prepared by the agency which shall be consolidated in the procuring entity's Annual Procurement Plan. (GPPB Circular No. 06-2019 dated 17 July 2019)

PSA – Philippine Statistics Authority.

SEC – Securities and Exchange Commission.

SLCC – Single Largest Completed Contract.

UN – United Nations.

Section I. Invitation to Bid

Notes on the Invitation to Bid

The Invitation to Bid (IB) provides information that enables potential Bidders to decide whether to participate in the procurement at hand. The IB shall be posted in accordance with Section 21.2 of the 2016 revised IRR of RA No. 9184.

Apart from the essential items listed in the Bidding Documents, the IB should also indicate the following:

- a. The date of availability of the Bidding Documents, which shall be from the time the IB is first advertised/posted until the deadline for the submission and receipt of bids;
- b. The place where the Bidding Documents may be acquired or the website where it may be downloaded;
- c. The deadline for the submission and receipt of bids; and
- d. Any important bid evaluation criteria.

The IB should be incorporated into the Bidding Documents. The information contained in the IB must conform to the Bidding Documents and in particular to the relevant information in the Bid Data Sheet.



Republic of the Philippines
Benguet State University
La Trinidad, 2601 Benguet
TeleFax (074) 661-1839
www.bsu.edu.ph



Invitation to Bid

IB 2024-26A Repair of the Poultry Project Office Building (Second Invitation to Bid)

1. The *Benguet State University (BSU)*, through the *General Appropriations Act – FY 2024* intends to apply the sum of *Two Million Two Hundred Thousand (Php. 2,200,000.00)* being the Approved Budget for the Contract (ABC) to payments under the contract for the *Repair of the Poultry Project Office Building – IB 2024-26A*. Bids received in excess of the ABC shall be automatically rejected at bid opening.
2. The *Benguet State University* now invites bids for the above Procurement Project. Completion of the Works is required *within 85 Calendar Days upon receipt of the Notice to Proceed*. Bidders should have completed a contract similar to the Project. The description of an eligible bidder is contained in the Bidding Documents, particularly, in Section II (Instructions to Bidders).
3. Bidding will be conducted through open competitive bidding procedures using non-discretionary “*pass/fail*” criterion as specified in the 2016 revised Implementing Rules and Regulations (IRR) of Republic Act (RA) No. 9184.
4. Interested bidders may obtain further information from *BSU-Bids and Awards Committee (BAC) Secretariat* through the contact details given below and inspect the Bidding Documents at the address given below from *8:00 AM to 5:00 PM office hours*.
5. A complete set of Bidding Documents may be acquired by interested bidders on *August 10, 2024 until August 16, 2024* from given address and website/s below, *and upon payment of the applicable fee for the Bidding Documents, pursuant to the latest Guidelines issued by the GPPB, in the amount of Three Thousand Pesos only (Php. 3,000.00)*.

Payment may be made in either mode, as follows:

- a. Payment, in person, to the BSU Cashier’s Office, First Floor, Administration Building, Km 5, Balili, La Trinidad, Benguet. The Procuring Entity shall allow the bidder to present its proof of payment for the fees which will be presented in person, by facsimile, or through electronic means.
- b. Online payment through the Landbank payment portal- <https://www.lbp-eservices.com/egps/portal/index.jsp>. Bidders shall present its confirmation receipt to

the BAC Secretariat in person, by facsimile, or through electronic means, which shall be used as proof of payment for the bidding documents fee.

6. The *Benguet State University* will not hold a Pre-Bid Conference
7. Bids must be duly received by the BAC Secretariat through **manual submission** at the office address as indicated below, on or before 2:00 PM, August 19, 2024. Late bids shall not be accepted.
8. All bids must be accompanied by a bid security in any of the acceptable forms and in the amount stated in **ITB** Clause 16.
9. Bid opening shall be on 2:15 PM, August 19, 2024 at the given address below and/or through *via Google Meet Platform at the link: meet.google.com/iih-nrds-cpo*. Bids will be opened in the presence of the bidders' representatives who choose to attend the activity.
10. The *Benguet State University* reserves the right to reject any and all bids, declare a failure of bidding, or not award the contract at any time prior to contract award in accordance with Sections 35.6 and 41 of the 2016 revised Implementing Rules and Regulations (IRR) of RA No. 9184, without thereby incurring any liability to the affected bidder or bidders.
11. For further information, please refer to:

*BAC Secretariat
Procurement Management Office (PMO)
Benguet State University – La Trinidad Campus
1/F Administration Building
Km. 5, La Trinidad, Benguet
Email: procurement@bsu.edu.ph
Telefax: (074) 661-1839*

12. You may visit the following websites:
For downloading of Bidding Documents: www.bsu.edu.ph/bids-awards

August 9, 2024

*(SGD) **SAMUEL S. POLIDEN**
Chairperson, Bids and Awards Committee*

Section II. Instructions to Bidders

Notes on the Instructions to Bidders

This Section on the Instruction to Bidders (ITB) provides the information necessary for bidders to prepare responsive bids, in accordance with the requirements of the Procuring Entity. It also provides information on bid submission, eligibility check, opening and evaluation of bids, post-qualification, and on the award of contract.

1. Scope of Bid

The Procuring Entity, *Benguet State University* invites Bids for the Repair of the Poultry Project Office Building (2nd Invitation to Bid), with Project Identification Number IB 2024-26A. The Procurement Project (referred to herein as “Project”) is for the construction of Works, as described in Section VI (Specifications).

2. Funding Information

- 2.1. The GOP through the source of funding as indicated below for *FY 2024* in the amount of *Php. 2,200,000.00*.
- 2.2. The source of funding is: *FY 2024 Business Type Income- Poultry Project*

3. Bidding Requirements

The Bidding for the Project shall be governed by all the provisions of RA No. 9184 and its 2016 revised IRR, including its Generic Procurement Manual and associated policies, rules and regulations as the primary source thereof, while the herein clauses shall serve as the secondary source thereof.

Any amendments made to the IRR and other GPPB issuances shall be applicable only to the ongoing posting, advertisement, or invitation to bid by the BAC through the issuance of a supplemental or bid bulletin.

The Bidder, by the act of submitting its Bid, shall be deemed to have inspected the site, determined the general characteristics of the contracted Works and the conditions for this Project, such as the location and the nature of the work; (b) climatic conditions; (c) transportation facilities; (c) nature and condition of the terrain, geological conditions at the site communication facilities, requirements, location and availability of construction aggregates and other materials, labor, water, electric power and access roads; and (d) other factors that may affect the cost, duration and execution or implementation of the contract, project, or work and examine all instructions, forms, terms, and project requirements in the Bidding Documents.

4. Corrupt, Fraudulent, Collusive, Coercive, and Obstructive Practices

The Procuring Entity, as well as the Bidders and Contractors, shall observe the highest standard of ethics during the procurement and execution of the contract. They or through an agent shall not engage in corrupt, fraudulent, collusive, coercive, and obstructive practices defined under Annex “I” of the 2016 revised IRR of RA No. 9184 or other integrity violations in competing for the Project.

5. Eligible Bidders

- 5.1. Only Bids or Bidders found to be legally, technically, and financially capable will be evaluated.
- 5.2. The Bidder must have an experience of having completed a Single Largest Completed Contract (SLCC) that is similar to this Project, equivalent to at least fifty percent (50%) of the ABC adjusted, if necessary, by the Bidder to current prices using the PSA's CPI, except under conditions provided for in Section 23.4.2.4 of the 2016 revised IRR of RA No. 9184.

A contract is considered to be "similar" to the contract to be bid if it has the major categories of work stated in the **BDS**.

- 5.3. For Foreign-funded Procurement, the Procuring Entity and the foreign government/foreign or international financing institution may agree on another track record requirement, as specified in the Bidding Document prepared for this purpose.
- 5.4. The Bidders shall comply with the eligibility criteria under Section 23.4.2 of the 2016 IRR of RA No. 9184.

6. Origin of Associated Goods

There is no restriction on the origin of Goods other than those prohibited by a decision of the UN Security Council taken under Chapter VII of the Charter of the UN.

7. Subcontracts

- 7.1. The Procuring Entity has prescribed that:
Subcontracting is not allowed.

8. Pre-Bid Conference

The Procuring Entity will not hold a pre-bid conference for this Project as indicated in paragraph 6 of the **IB**.

9. Clarification and Amendment of Bidding Documents

Prospective bidders may request for clarification on and/or interpretation of any part of the Bidding Documents. Such requests must be in writing and received by the Procuring Entity, either at its given address or through electronic mail indicated in the **IB**, at least ten (10) calendar days before the deadline set for the submission and receipt of Bids.

10. Documents Comprising the Bid: Eligibility and Technical Components

- 10.1. The first envelope shall contain the eligibility and technical documents of the Bid as specified in **Section IX. Checklist of Technical and Financial Documents**.
- 10.2. If the eligibility requirements or statements, the bids, and all other documents for submission to the BAC are in foreign language other than English, it must be accompanied by a translation in English, which shall be authenticated by the appropriate Philippine foreign service establishment, post, or the equivalent office having jurisdiction over the foreign bidder's affairs in the Philippines. For Contracting

Parties to the Apostille Convention, only the translated documents shall be authenticated through an apostille pursuant to GPPB Resolution No. 13-2019 dated 23 May 2019. The English translation shall govern, for purposes of interpretation of the bid.

- 10.3. A valid special PCAB License in case of Joint Ventures, and registration for the type and cost of the contract for this Project. Any additional type of Contractor license or permit shall be indicated in the **BDS**.
- 10.4. A List of Contractor's key personnel (e.g., Project Manager, Project Engineers, Materials Engineers, and Foremen) assigned to the contract to be bid, with their complete qualification and experience data shall be provided. These key personnel must meet the required minimum years of experience set in the **BDS**.
- 10.5. A List of Contractor's major equipment units, which are owned, leased, and/or under purchase agreements, supported by proof of ownership, certification of availability of equipment from the equipment lessor/vendor for the duration of the project, as the case may be, must meet the minimum requirements for the contract set in the **BDS**.

11. Documents Comprising the Bid: Financial Component

- 11.1. The second bid envelope shall contain the financial documents for the Bid as specified in **Section IX. Checklist of Technical and Financial Documents**.
- 11.2. Any bid exceeding the ABC indicated in paragraph 1 of the **IB** shall not be accepted.
- 11.3. For Foreign-funded procurement, a ceiling may be applied to bid prices provided the conditions are met under Section 31.2 of the 2016 revised IRR of RA No. 9184.

12. Alternative Bids

Bidders shall submit offers that comply with the requirements of the Bidding Documents, including the basic technical design as indicated in the drawings and specifications. Unless there is a value engineering clause in the **BDS**, alternative Bids shall not be accepted.

13. Bid Prices

All bid prices for the given scope of work in the Project as awarded shall be considered as fixed prices, and therefore not subject to price escalation during contract implementation, except under extraordinary circumstances as determined by the NEDA and approved by the GPPB pursuant to the revised Guidelines for Contract Price Escalation guidelines.

14. Bid and Payment Currencies

14.1. Bid prices may be quoted in the local currency or tradeable currency accepted by the BSP at the discretion of the Bidder. However, for purposes of bid evaluation, Bids denominated in foreign currencies shall be converted to Philippine currency based on the exchange rate as published in the BSP reference rate bulletin on the day of the bid opening.

14.2. Payment of the contract price shall be made in: **Philippine Pesos**.

15. Bid Security

- 15.1. The Bidder shall submit a Bid Securing Declaration or any form of Bid Security in the amount indicated in the **BDS**, which shall be not less than the percentage of the ABC in accordance with the schedule in the **BDS**.
- 15.2. The Bid and bid security shall be valid until *December 7, 2024 or One hundred Twenty (120) calendar days from opening of bids*. Any bid not accompanied by an acceptable bid security shall be rejected by the Procuring Entity as non-responsive.

16. Sealing and Marking of Bids

Each Bidder shall submit **three (3) copies of the first and second components of its Bid**. It will be marked as original, Copy 1 and copy 2.

The Procuring Entity may request additional hard copies and/or electronic copies of the Bid. However, failure of the Bidders to comply with the said request shall not be a ground for disqualification.

If the Procuring Entity allows the submission of bids through online submission to the given website or any other electronic means, the Bidder shall submit an electronic copy of its Bid, which must be digitally signed. An electronic copy that cannot be opened or is corrupted shall be considered non-responsive and, thus, automatically disqualified.

17. Deadline for Submission of Bids

The Bidders shall submit on the specified date and time and either at its physical address or through online submission as indicated in paragraph 7 of the **IB**.

18. Opening and Preliminary Examination of Bids

- 18.1. The BAC shall open the Bids in public at the time, on the date, and at the place specified in paragraph 9 of the **IB**. The Bidders' representatives who are present shall sign a register evidencing their attendance. In case videoconferencing, webcasting or other similar technologies will be used, attendance of participants shall likewise be recorded by the BAC Secretariat.

In case the Bids cannot be opened as scheduled due to justifiable reasons, the rescheduling requirements under Section 29 of the 2016 revised IRR of RA No. 9184 shall prevail.

- 18.2. The preliminary examination of Bids shall be governed by Section 30 of the 2016 revised IRR of RA No. 9184.

19. Detailed Evaluation and Comparison of Bids

- 19.1. The Procuring Entity's BAC shall immediately conduct a detailed evaluation of all Bids rated "*passed*" using non-discretionary pass/fail criteria. The BAC shall

consider the conditions in the evaluation of Bids under Section 32.2 of 2016 revised IRR of RA No. 9184.

- 19.2. If the Project allows partial bids, all Bids and combinations of Bids as indicated in the **BDS** shall be received by the same deadline and opened and evaluated simultaneously so as to determine the Bid or combination of Bids offering the lowest calculated cost to the Procuring Entity. Bid Security as required by **ITB** Clause 15 shall be submitted for each contract (lot) separately.
- 19.3. In all cases, the NFCC computation pursuant to Section 23.4.2.6 of the 2016 revised IRR of RA No. 9184 must be sufficient for the total of the ABCs for all the lots participated in by the prospective Bidder.

20. Post Qualification

Within a non-extendible period of five (5) calendar days from receipt by the Bidder of the notice from the BAC that it submitted the Lowest Calculated Bid, the Bidder shall submit its latest income and business tax returns filed and paid through the BIR Electronic Filing and Payment System (eFPS), and other appropriate licenses and permits required by law and stated in the **BDS**.

21. Signing of the Contract

The documents required in Section 37.2 of the 2016 revised IRR of RA No. 9184 shall form part of the Contract. Additional Contract documents are indicated in the **BDS**.

Section III. Bid Data Sheet

Notes on the Bid Data Sheet (BDS)

The Bid Data Sheet (BDS) consists of provisions that supplement, amend, or specify in detail, information, or requirements included in the ITB found in Section II, which are specific to each procurement.

This Section is intended to assist the Procuring Entity in providing the specific information in relation to corresponding clauses in the ITB and has to be prepared for each specific procurement.

The Procuring Entity should specify in the BDS information and requirements specific to the circumstances of the Procuring Entity, the processing of the procurement, and the bid evaluation criteria that will apply to the Bids. In preparing the BDS, the following aspects should be checked:

- a. Information that specifies and complements provisions of the ITB must be incorporated.
- b. Amendments and/or supplements, if any, to provisions of the ITB as necessitated by the circumstances of the specific procurement, must also be incorporated.

Bid Data Sheet

ITB Clause																									
5.2	<p>For this purpose, contracts similar to the Project refer to contracts which have the same major categories of work, which shall be:</p> <p>a. Repair of buildings with at least 50% similarities with the major work component of the project;</p> <p>b. Have been completed within 5 years prior to submission of bids</p>																								
7.1	<i>Subcontracting is not allowed</i>																								
10.3	<p><i>PCAB License requirement shall be:</i></p> <p><i>Size Range: Small B</i></p> <p><i>License Category: C & D</i></p> <p><i>Principal Classification: General building/ General Engineering</i></p>																								
10.4	<p>The key personnel must meet the required minimum years of experience set below:</p> <table border="1" style="width: 100%; border-collapse: collapse; margin-bottom: 10px;"> <thead> <tr> <th style="width: 30%;">Key Personnel</th> <th style="width: 15%;">No. of Personnel</th> <th style="width: 20%;">General Experience</th> <th style="width: 35%;">Relevant Experience</th> </tr> </thead> <tbody> <tr> <td><i>Site Engineer/ Site Architect</i></td> <td style="text-align: center;"><i>1</i></td> <td><i>At least 3 years</i></td> <td><i>At least 3 years</i></td> </tr> <tr> <td><i>Safety Officer – Part time, with COSH training from accredited provider by DOLE</i></td> <td style="text-align: center;"><i>1</i></td> <td><i>At least 3 years</i></td> <td><i>At least 3 years</i></td> </tr> <tr> <td><i>Electrical Engineer/ Registered Master Electrician</i></td> <td style="text-align: center;"><i>1</i></td> <td><i>At least 3 years</i></td> <td><i>At least 3 years</i></td> </tr> <tr> <td><i>Sanitary Engineer/ Registered Master Plumber</i></td> <td style="text-align: center;"><i>1</i></td> <td><i>At least 3 years</i></td> <td><i>At least 3 years</i></td> </tr> <tr> <td><i>Construction Foreman</i></td> <td style="text-align: center;"><i>1</i></td> <td><i>At least 3 years</i></td> <td><i>At least 3 years</i></td> </tr> </tbody> </table> <p>Note:</p> <ol style="list-style-type: none"> 1. All the key personnel should have applicable and prescribed General and Relevant Experiences in line on specialization. 2. Key personnel must have valid PRC licenses/certificates and PTR 	Key Personnel	No. of Personnel	General Experience	Relevant Experience	<i>Site Engineer/ Site Architect</i>	<i>1</i>	<i>At least 3 years</i>	<i>At least 3 years</i>	<i>Safety Officer – Part time, with COSH training from accredited provider by DOLE</i>	<i>1</i>	<i>At least 3 years</i>	<i>At least 3 years</i>	<i>Electrical Engineer/ Registered Master Electrician</i>	<i>1</i>	<i>At least 3 years</i>	<i>At least 3 years</i>	<i>Sanitary Engineer/ Registered Master Plumber</i>	<i>1</i>	<i>At least 3 years</i>	<i>At least 3 years</i>	<i>Construction Foreman</i>	<i>1</i>	<i>At least 3 years</i>	<i>At least 3 years</i>
Key Personnel	No. of Personnel	General Experience	Relevant Experience																						
<i>Site Engineer/ Site Architect</i>	<i>1</i>	<i>At least 3 years</i>	<i>At least 3 years</i>																						
<i>Safety Officer – Part time, with COSH training from accredited provider by DOLE</i>	<i>1</i>	<i>At least 3 years</i>	<i>At least 3 years</i>																						
<i>Electrical Engineer/ Registered Master Electrician</i>	<i>1</i>	<i>At least 3 years</i>	<i>At least 3 years</i>																						
<i>Sanitary Engineer/ Registered Master Plumber</i>	<i>1</i>	<i>At least 3 years</i>	<i>At least 3 years</i>																						
<i>Construction Foreman</i>	<i>1</i>	<i>At least 3 years</i>	<i>At least 3 years</i>																						
10.5	<p>The minimum major equipment requirements are the following:</p> <table border="1" style="width: 100%; border-collapse: collapse; margin-top: 10px;"> <thead> <tr> <th style="width: 40%;">Equipment</th> <th style="width: 30%;">Capacity</th> <th style="width: 30%;">Number of Units</th> </tr> </thead> <tbody> <tr> <td><i>Welding Machine</i></td> <td></td> <td style="text-align: center;"><i>1</i></td> </tr> <tr> <td><i>Jackhammer</i></td> <td></td> <td style="text-align: center;"><i>1</i></td> </tr> <tr> <td><i>Concrete Saw</i></td> <td></td> <td style="text-align: center;"><i>1</i></td> </tr> <tr> <td><i>One-Bagger Mixer</i></td> <td></td> <td style="text-align: center;"><i>1</i></td> </tr> </tbody> </table>	Equipment	Capacity	Number of Units	<i>Welding Machine</i>		<i>1</i>	<i>Jackhammer</i>		<i>1</i>	<i>Concrete Saw</i>		<i>1</i>	<i>One-Bagger Mixer</i>		<i>1</i>									
Equipment	Capacity	Number of Units																							
<i>Welding Machine</i>		<i>1</i>																							
<i>Jackhammer</i>		<i>1</i>																							
<i>Concrete Saw</i>		<i>1</i>																							
<i>One-Bagger Mixer</i>		<i>1</i>																							

	<i>Bar Bender</i>		1
	<i>Bar Cutter</i>		1
	<i>Dump truck</i>	10 y.d capacity	1
	<i>Plate Compactor</i>	5 HP	1
12	<i>Alternative Bid is not Allowed</i>		
15.1	<p>The bid security shall be in the form of a Bid Securing Declaration or any of the following forms and amounts:</p> <p>a. The amount of not less than 2% of ABC or Php. 44,000.00, if bid security is in cash, cashier's/manager's check, bank draft/guarantee or irrevocable letter of credit;</p> <p>b. The amount of not less than 5% of ABC or Php. 110,000.00 if bid security is in Surety Bond.</p>		
16	<p>The Procuring Entity may request additional hard copies and/or electronic copies of the Bid; hence, each bidder shall submit 1 copy of original and 2 copies of the first and second components of its bids marked as original, copy 1 and copy 2, respectively.</p> <p>** in the original copy of the bid: All the photocopied documents must be certified as true copy indicating the Name and Position of the signatory.</p>		
19.2	Partial bids are not allowed.		
20	<p>The bidder with the Lowest Calculated Bid shall submit ALL of the following post-qualification requirements:</p> <p>a. Latest Income and Business Tax returns, filed and paid through the Electronic Filing and Payment System (EFPS), consisting of the following:</p> <p>i. 2023 Income tax Returns with proof of payment; and</p> <p>ii. VAT returns or Percentage Tax Returns with proof of payment covering six (6) months prior to the bid opening</p>		
21	<p>Additional contract documents relevant to the Project as required:</p> <p>a. PERT/CPM</p> <p>b. Construction Safety and Health Program duly approved by DOLE;</p> <p>c. Construction Schedule and S-curve;</p> <p>d. Manpower Schedule;</p> <p>e. Construction Methods;</p> <p>f. Updated Program of works showing general methods, arrangement, order and timing for all activities in the works;</p> <p>g. Equipment Utilization Scheduled; and</p> <p>h. Contractor's All Risk Insurance (CARI)</p>		

Section IV. General Conditions of Contract

Notes on the General Conditions of Contract

The General Conditions of Contract (GCC) in this Section, read in conjunction with the Special Conditions of Contract in Section V and other documents listed therein, should be a complete document expressing all the rights and obligations of the parties.

Matters governing performance of the Contractor, payments under the contract, or matters affecting the risks, rights, and obligations of the parties under the contract are included in the GCC and Special Conditions of Contract.

Any complementary information, which may be needed, shall be introduced only through the Special Conditions of Contract.

1. Scope of Contract

This Contract shall include all such items, although not specifically mentioned, that can be reasonably inferred as being required for its completion as if such items were expressly mentioned herein. All the provisions of RA No. 9184 and its 2016 revised IRR, including the Generic Procurement Manual, and associated issuances, constitute the primary source for the terms and conditions of the Contract, and thus, applicable in contract implementation. Herein clauses shall serve as the secondary source for the terms and conditions of the Contract.

This is without prejudice to Sections 74.1 and 74.2 of the 2016 revised IRR of RA No. 9184 allowing the GPPB to amend the IRR, which shall be applied to all procurement activities, the advertisement, posting, or invitation of which were issued after the effectivity of the said amendment.

2. Sectional Completion of Works

If sectional completion is specified in the **Special Conditions of Contract (SCC)**, references in the Conditions of Contract to the Works, the Completion Date, and the Intended Completion Date shall apply to any Section of the Works (other than references to the Completion Date and Intended Completion Date for the whole of the Works).

3. Possession of Site

3.1 The Procuring Entity shall give possession of all or parts of the Site to the Contractor based on the schedule of delivery indicated in the **SCC**, which corresponds to the execution of the Works. If the Contractor suffers delay or incurs cost from failure on the part of the Procuring Entity to give possession in accordance with the terms of this clause, the Procuring Entity's Representative shall give the Contractor a Contract Time Extension and certify such sum as fair to cover the cost incurred, which sum shall be paid by Procuring Entity.

3.2 If possession of a portion is not given by the above date, the Procuring Entity will be deemed to have delayed the start of the relevant activities. The resulting adjustments in contract time to address such delay may be addressed through contract extension provided under Annex "E" of the 2016 revised IRR of RA No. 9184.

4. The Contractor's Obligations

The Contractor shall employ the key personnel named in the Schedule of Key Personnel indicating their designation, in accordance with **ITB** Clause 10.3 and specified in the **BDS**, to carry out the supervision of the Works.

The Procuring Entity will approve any proposed replacement of key personnel only if their relevant qualifications and abilities are equal to or better than those of the personnel listed in the Schedule.

5. Performance Security

- 5.1. Within ten (10) calendar days from receipt of the Notice of Award from the Procuring Entity but in no case later than the signing of the contract by both parties, the successful Bidder shall furnish the performance security in any of the forms prescribed in Section 39 of the 2016 revised IRR.
- 5.2. The Contractor, by entering into the Contract with the Procuring Entity, acknowledges the right of the Procuring Entity to institute action pursuant to RA No. 3688 against any subcontractor be they an individual, firm, partnership, corporation, or association supplying the Contractor with labor, materials and/or equipment for the performance of this Contract.

6. Site Investigation Reports

The Contractor, in preparing the Bid, shall rely on any Site Investigation Reports referred to in the **SCC** supplemented by any information obtained by the Contractor.

7. Warranty

- 7.1. In case the Contractor fails to undertake the repair works under Section 62.2.2 of the 2016 revised IRR, the Procuring Entity shall forfeit its performance security, subject its property(ies) to attachment or garnishment proceedings, and perpetually disqualify it from participating in any public bidding. All payables of the GOP in his favor shall be offset to recover the costs.
- 7.2. The warranty against Structural Defects/Failures, except that occasioned-on force majeure, shall cover the period from the date of issuance of the Certificate of Final Acceptance by the Procuring Entity. Specific duration of the warranty is found in the **SCC**.

8. Liability of the Contractor

Subject to additional provisions, if any, set forth in the **SCC**, the Contractor's liability under this Contract shall be as provided by the laws of the Republic of the Philippines.

If the Contractor is a joint venture, all partners to the joint venture shall be jointly and severally liable to the Procuring Entity.

9. Termination for Other Causes

Contract termination shall be initiated in case it is determined *prima facie* by the Procuring Entity that the Contractor has engaged, before, or during the implementation of the contract, in unlawful deeds and behaviors relative to contract acquisition and implementation, such as, but not limited to corrupt, fraudulent, collusive, coercive, and obstructive practices as stated in **ITB** Clause 4.

10. Dayworks

Subject to the guidelines on Variation Order in Annex "E" of the 2016 revised IRR of RA No. 9184, and if applicable as indicated in the **SCC**, the Dayworks rates in the Contractor's Bid shall be used for small additional amounts of work only when the Procuring Entity's Representative has given written instructions in advance for additional work to be paid for in that way.

11. Program of Work

- 11.1. The Contractor shall submit to the Procuring Entity's Representative for approval the said Program of Work showing the general methods, arrangements, order, and timing for all the activities in the Works. The submissions of the Program of Work are indicated in the **SCC**.
- 11.2. The Contractor shall submit to the Procuring Entity's Representative for approval an updated Program of Work at intervals no longer than the period stated in the **SCC**. If the Contractor does not submit an updated Program of Work within this period, the Procuring Entity's Representative may withhold the amount stated in the **SCC** from the next payment certificate and continue to withhold this amount until the next payment after the date on which the overdue Program of Work has been submitted.

12. Instructions, Inspections and Audits

The Contractor shall permit the GOP or the Procuring Entity to inspect the Contractor's accounts and records relating to the performance of the Contractor and to have them audited by auditors of the GOP or the Procuring Entity, as may be required.

13. Advance Payment

The Procuring Entity shall, upon a written request of the Contractor which shall be submitted as a Contract document, make an advance payment to the Contractor in an amount not exceeding fifteen percent (15%) of the total contract price, to be made in lump sum, or at the most two installments according to a schedule specified in the **SCC**, subject to the requirements in Annex "E" of the 2016 revised IRR of RA No. 9184.

14. Progress Payments

The Contractor may submit a request for payment for Work accomplished. Such requests for payment shall be verified and certified by the Procuring Entity's Representative/Project Engineer. Except as otherwise stipulated in the **SCC**, materials and equipment delivered on the site but not completely put in place shall not be included for payment.

15. Operating and Maintenance Manuals

- 15.1. If required, the Contractor will provide "as built" Drawings and/or operating and maintenance manuals as specified in the **SCC**.
- 15.2. If the Contractor does not provide the Drawings and/or manuals by the dates stated above, or they do not receive the Procuring Entity's Representative's approval, the Procuring Entity's Representative may withhold the amount stated in the **SCC** from payments due to the Contractor.

Section V. Special Conditions of Contract

Notes on the Special Conditions of Contract

Similar to the BDS, the clauses in this Section are intended to assist the Procuring Entity in providing contract-specific information in relation to corresponding clauses in the GCC found in Section IV.

The Special Conditions of Contract (SCC) complement the GCC, specifying contractual requirements linked to the special circumstances of the Procuring Entity, the Procuring Entity's country, the sector, and the Works procured. In preparing this Section, the following aspects should be checked:

- a. Information that complements provisions of the GCC must be incorporated.
- b. Amendments and/or supplements to provisions of the GCC as necessitated by the circumstances of the specific purchase, must also be incorporated.

However, no special condition which defeats or negates the general intent and purpose of the provisions of the GCC should be incorporated herein.

Special Conditions of Contract

GCC Clause	
2	<i>No further instructions</i>
4.1	<i>The Benguet State University shall give possession of all parts of the Site to the Contractor upon receipt of the Notice to Proceed.</i>
6	<i>No further instructions</i>
7.2	<i>In case of permanent structures, such as buildings of types 4 and 5 as classified under the National Building Code of the Philippines and other structures made of steel, iron, or concrete which comply with relevant structural codes (e.g., DPWH Standard Specifications), such as, but not limited to, steel/concrete bridges, flyovers, aircraft movement areas, ports, dams, tunnels, filtration and treatment plants, sewerage systems, power plants, transmission and communication towers, railway system, and other similar permanent structures: Fifteen (15) years.</i>
10	Dayworks are applicable at the rate shown in the Contractor's original Bid.
11.1	The Contractor shall submit the updated Program of Work to the Procuring Entity's Representative within ten (10) days upon receipt of the Notice of Award.
11.2	The amount to be withheld for late submission of an updated Program of Work is 1% of the ABC or Php. 22,000.00.
13	The amount of the advance payment is equivalent to fifteen percent (15%) <i>of the total contract price to be paid in a lump sum by BSU.</i>
14	Materials and equipment delivered on the site but not completely put in place shall not be included for payment.
15.1	The date by which operating and maintenance manuals are required is within seven (7) calendar days upon completion of the project. The date by which "as built" drawings are required is within seven (7) after the completion.
15.2	The amount to be withheld for failing to produce "as built" drawings and/or operating and maintenance manuals by the date required is 1% of the ABC or Php. 22,000.00.

Section VI. Specifications

Notes on Specifications

A set of precise and clear specifications is a prerequisite for Bidders to respond realistically and competitively to the requirements of the Procuring Entity without qualifying or conditioning their Bids. In the context of international competitive bidding, the specifications must be drafted to permit the widest possible competition and, at the same time, present a clear statement of the required standards of workmanship, materials, and performance of the goods and services to be procured. Only if this is done will the objectives of economy, efficiency, and fairness in procurement be realized, responsiveness of Bids be ensured, and the subsequent task of bid evaluation facilitated. The specifications should require that all goods and materials to be incorporated in the Works be new, unused, of the most recent or current models, and incorporate all recent improvements in design and materials unless provided otherwise in the Contract.

Samples of specifications from previous similar projects are useful in this respect. The use of metric units is mandatory. Most specifications are normally written specially by the Procuring Entity or its representative to suit the Works at hand. There is no standard set of Specifications for universal application in all sectors in all regions, but there are established principles and practices, which are reflected in these PBDs.

There are considerable advantages in standardizing General Specifications for repetitive Works in recognized public sectors, such as highways, ports, railways, urban housing, irrigation, and water supply, in the same country or region where similar conditions prevail. The General Specifications should cover all classes of workmanship, materials, and equipment commonly involved in construction, although not necessarily to be used in a particular Works Contract. Deletions or addenda should then adapt the General Specifications to the particular Works.

Care must be taken in drafting specifications to ensure that they are not restrictive. In the specification of standards for goods, materials, and workmanship, recognized international standards should be used as much as possible. Where other particular standards are used, whether national standards or other standards, the specifications should state that goods, materials, and workmanship that meet other authoritative standards, and which ensure substantially equal or higher quality than the standards mentioned, will also be acceptable. The following clause may be inserted in the SCC.

Sample Clause: Equivalency of Standards and Codes

Wherever reference is made in the Contract to specific standards and codes to be met by the goods and materials to be furnished, and work performed or tested, the provisions of the latest current edition or revision of the relevant standards and codes in effect shall

apply, unless otherwise expressly stated in the Contract. Where such standards and codes are national, or relate to a particular country or region, other authoritative standards that ensure a substantially equal or higher quality than the standards and codes specified will be accepted subject to the Procuring Entity's Representative's prior review and written consent. Differences between the standards specified and the proposed alternative standards shall be fully described in writing by the Contractor and submitted to the Procuring Entity's Representative at least twenty-eight (28) days prior to the date when the Contractor desires the Procuring Entity's Representative's consent. In the event the Procuring Entity's Representative determines that such proposed deviations do not ensure substantially equal or higher quality, the Contractor shall comply with the standards specified in the documents.

These notes are intended only as information for the Procuring Entity or the person drafting the Bidding Documents. They should not be included in the final Bidding Documents.

TECHNICAL SPECIFICATIONS

Name of Project: **REPAIR OF THE POULTRY OFFICE BUILDING**

Location: BALILI, BSU LA TRINIDAD CAMPUS, LA TRINIDAD, BENGUET

B.3 – PERMITS AND CLEARANCES (BUILDING PERMIT)

B.3.1 Description

This item shall consist of securing building permit documents before construction and occupancy permit after the construction of the building.

B.3.2 Method of Measurement

The accepted quantities, measured as prescribed in section B.3.1 shall be paid for at the contract unit price for regulatory permits which price and payment shall be full compensation for furnishing and placing all materials, including all labor, equipment, tools, and incidentals necessary to complete the work prescribed in this item.

B.3.3 Basis of Payment

Payment will be made under:

Pay Item No.	Description	Unit of Measurement
B.3	PERMITS AND CLEARANCES (BUILDING PERMIT)	LUMP SUM

B.5 - PROJECT BILLBOARD / SIGNBOARD

B.5.1 Material Requirements:

Tarpaulin

The design and format of the tarpaulin shall have the following specifications:

Color	: White
Size	: 8 ft. x 8 ft.
Resolution	: 70 dpi
Font	: Helvetica
Font Size of Main Information	: 3 inches
Font Size of Sub-Information	: 1 inch
Font Color	: Black
Suitable Frame	: Rigid wood frame with post; and
Posting	: Outside display at the project location after award has been made.

The information shall contain but not limited to i.) logo of the funding agencies, ii.) the name of implementing agencies, iii.) name of contractor, iv.) project's title, location, cost and description, v.) project details to include duration, date started, target date of completion and project status, and vi.) COA Anti-corruption Hotline.

The display/and or affixture of the picture, image, motto, logo, color motif, initials or other symbol or graphic representation associated with the top leadership of the project proponent or implementing agency/unit/office, on project billboard, is considered unnecessary. (General Guidelines No. 2.2.6)

B.5.2 Post and Frame

Posts and frames/braces shall be made from good lumber with a 2X3 and 2x2 inches size respectively and shall be well-seasoned, straight and free of injurious defects. The frame will be covered with 2 pieces ¼ inch thick marine plywood where the tarpaulin will be attached.

B.5.3 Method of Measurement

The quantities of project billboard shall be in pieces of such signs of the size specified, including the necessary posts and supports erected and accepted.

B.5.4 Basis of Payment

The quantities measured as determined in the Method of Measurement, shall be paid for at the contract unit price for the Pay Items shown in the Bid Schedule which price and payment shall be full compensation for furnishing and installing project billboard, all labor, equipment, tools and incidentals necessary to complete the Item.

Payment will be made under:

Pay Item No.	Description	Unit of Measurement
B.5	Project Billboard / Signboard	Each

ITEM B.7 – OCCUPATIONAL SAFETY AND HEALTH PROGRAM

B.7.1 Description

A Company Safety Policy which shall serve as the general guiding principles in the implementation of safety and health on site duly signed by the highest company official or his duly authorized representative who has the over---all control of project execution and should include the contractor's general policy towards occupational safety, worker's welfare and health, and environment.

A Safety policy, which shall include the commitment that the contractor shall comply with DOLE minimum safety requirements, including reporting requirements of the Occupational Health and Safety Standards (OSHS), and other relevant DOLE issuances. These may include, but are not limited to the following:

Registration (Rule 1020 and DO 18--02)

Report of Safety Committee Organization (Rule 1040)

Notification of Accidents and Occupational Illnesses (Rule 1050)

Annual Work Accident/Illness Exposure Data Report (Rule 1050)

Application for installation of mechanical/electrical equipment for construction of structure for industrial use (Rule 1070 and 1160)

Annual Medical Report (Rule 1960)

1.2 *Specific Construction Safety and Health Program* shall contain the tendering agency's requirements in addition to the minimum requirements under the appropriate sections of D.O. No. 13 whenever deemed as applicable.

B.7.2 Method of Measurement

Payment shall be made on a proportional basis, calculated by multiplying the percentage rate of physical progress to the total lump sum amount every progress billing.

B.7.3 Basis of Payment

Payment will be made under:

Pay Item Number	Description	Unit of Measurement
B.7	Occupational Safety and Health Program	Lump Sum

ITEM B.9 – MOBILIZATION / DEMOBILIZATION

B.9.1 Description

This item shall consist of the mobilization and demobilization of equipment needed for the project. In addition, this item also includes the cleaning of the project site including its surroundings before the final inspection.

B.9.2 Method of Measurement

The accepted quantities, measured as prescribed in section B.9.1 shall be paid for at the contract unit price for mobilization / demobilization which price and payment shall be full compensation for furnishings and placing all materials, including all labor, equipment, tools, and incidentals necessary to complete the work prescribed in this item.

B.9.3 Basis of Payment

Payment will be made under:

Pay Item Number	Description	Unit of Measurement
B.9	MOBILIZATION / DEMOBILIZATION	LUMP SUM

ITEM 803(1)a – STRUCTURE EXCAVATION (COMMON SOIL)

803.1 Description

This Item shall consist of the necessary excavation for foundation of the motor pool, and other structures not otherwise provided for in the Specifications.

It shall also include the furnishing and placing of approved foundation fill material to replace unsuitable material encountered below the foundation elevation of structures.

No allowance will be made for classification of different types of material encountered.

803(1)a.2 Construction Requirements

803(1)a.2.1 Clearing and Grubbing

Prior to starting excavation operations in any area, all necessary clearing and grubbing in that area shall have been performed in accordance with Item 100, Clearing and Grubbing.

803(1)a.2.2 Excavation

General, all structures. The Contractor shall notify the Engineer sufficiently in advance of the beginning of any excavation so that cross-sectional elevations and measurements may be taken on the undisturbed ground. The natural ground adjacent to the structure shall not be disturbed without permission of the Engineer.

Trenches or foundation pits for structures or structure footings shall be excavated to the lines and grades or elevations shown on the Plans or as staked by the Engineer. They shall be of sufficient size to permit the placing of structures or structure footings of the full width and length shown in the Structural Plan under Footing Schedule. The elevations of the bottoms of footings, as shown on the Plans, shall be considered as approximate only and the Engineer may order, in writing, such changes in dimensions or elevations of footings as may be deemed necessary, to secure a satisfactory foundation.

Trenches or foundation pits for structures or structure footings shall be excavated to the lines and grades or elevations shown on the Plans or as staked by the Engineer. They shall be of sufficient size to permit the placing of structures or structure footings of the full width and length shown. The elevations of the bottoms of footings, as shown on the Plans, shall be considered as approximate only and the Engineer may order, in writing, such changes in dimensions or elevations of footings as may be deemed necessary, to secure a satisfactory foundation.

803(1)a.2.3 Utilization of Excavated Materials

All excavated materials, so far as suitable, shall be utilized as backfill or embankment. The surplus materials shall be disposed off in such manner as not to obstruct the stream or otherwise impair the efficiency or appearance of the Structure. No excavated materials shall be deposited at any time so as to endanger the partly finished structure.

803(1)a.3 Method of Measurement

The volume of excavation to be paid for will be the number of cubic meters measured in original position of material acceptably excavated in conformity with the Plans or as directed by the Engineer:

Pay Item Number	Description	Unit of Measurement
803(1)a	STRUCTURE EXCAVATION (COMMON SOIL)	Cu.m.

ITEM 804 – EMBANKMENT (BACKFILL FROM STRUCTURE EXCAVATION)

804(1)a.1 Description

This Item shall consist of the backfilling of the excavated footings and preparation of base materials for the slab-on-fill as indicated in the plan and specification.

It shall also include the furnishing and placing of approved foundation fill material to replace unsuitable material encountered below the foundation elevation of structures.

804(1)a.2 Construction Requirements

Embankment for the base of the slab-on-fill of earth material shall be placed in horizontal layers not exceeding 200 mm (8 inches), loose measurement, and shall be compacted as specified before the next layer is placed. However, thicker layer maybe placed if vibratory roller with high compactive effort is used provided that density requirement is attained and as approved by the Engineer. Trial section to this effect must be conducted and approved by the Engineer. Effective spreading equipment shall be used on each lift to obtain uniform thickness as determined in the trial section prior to compaction. As the compaction of each layer progresses, continuous leveling and manipulating will be required to assure uniform density. Water shall be added or removed, if necessary, in order to obtain the required density. Removal of water shall be accomplished through aeration by plowing, blading, discing, or other methods satisfactory to the Engineer.

Throughout the periods when compaction of earthwork is in progress, the Contractor shall adhere to the compaction procedures found from compaction trials for each type of material being compacted, each type of compaction equipment employed and each degree of compaction specified.

804(1)a.3 Method of Measurement

The volume of embankment (Backfill from Structure Excavation) to be paid for will be the number of cubic meters measured in original position of material acceptably backfilled and compacted in conformity with the Plans or as directed by the Engineer:

Pay Item Number	Description	Unit of Measurement
804(1)a	EMBANKMENT (BACKFILL FROM STRUCTURE EXCAVATION)	Cu.m.

ITEM 804(4) – GRAVEL BEDDING

804(4).1 Description

This Item shall consist of placing and compacting of gravel bedding materials for the footing and slab-on-fill as indicated in the plan and specification.

It shall also include the furnishing and placing of approved foundation fill material to replace unsuitable material encountered below the foundation elevation of structures.

804(4).2 Material and Construction Requirements

Materials for this item is a G1 Gravel as indicated in the DUPA for this item.

Throughout the periods when compaction of gravel fill is in progress, the contractor shall adhere to the compaction procedures found from compaction trials for each type of material being compacted, each type of compaction equipment employed and each degree of compaction specified.

804(4).3 Method of Measurement

The volume of G1 gravel bedding of footings and slab on fill to be paid for will be the number of cubic meters measured in original position of material acceptably of compacted gravel in conformity with the Plans or as directed by the Engineer:

Pay Item Number	Description	Unit of Measurement
804(4)	GRAVEL BEDDING	Cu.m.

ITEM 900(7) - REINFORCED CONCRETE (3500 PSI @ 28 DAYS)

900(7).1 Description

This Item shall consist of furnishing, placing and finishing concrete in buildings and related structures in accordance with this specification and conforming to the lines, grades, and dimension shown on the plans.

900(7).2 Materials Requirements

900(7).2.1 Portland Cement

This shall conform to the requirement of ITEM 700, Volume II (Blue Book), Hydraulic cement.

900(7).2.2 Concrete Aggregates

Concrete aggregate shall conform to the requirements of subsection 311.2.2 and 311.2.3 under Item 311 of Volume II, (Blue Book) and ASTM C 33 for lightweight aggregates, except that aggregates failing to meet these specifications but which have been shown by special that or actual service to produce concrete of adequate strength and durability may be used under method (2) of determining the proportion of concrete, where authorized by the Engineer.

Except as permitted elsewhere in this section, the maximum size of the aggregate shall be not larger than one-fifth (1/5) of the narrowest dimensions between sides of forms of the member for which the concrete is to be used nor larger than three-fourths of the minimum clear spacing between individual reinforcing bars or bundles of bars or pretensioning strands.

900(7).2.2.1 Aggregate Tests

Samples of the fine and coarse aggregates to be used shall be selected by the Engineer for tests at least 30 days before the actual concreting operations are to begin. It shall be the responsibility of the contractor to designate the source or sources of aggregate to give the Engineer sufficient time to obtain the necessary samples and submit them for testing.

No aggregate shall be used until official advice has been received that it has satisfactorily passed all test, at which time written authority shall be given for its use.

900(7).2.3 Water

Water used in mixing concrete shall conform to the requirement of subsection 311.2.4 under Item 311, Part E, of Volume II, (BlueBook).

900(7).2.4 Metal Reinforcement

Reinforcing steel bars shall conform to the requirements of the following Specifications:

Deformed & Plain Billet Steel Bars for concrete Reinforcement (ASTM A 615)

Bars for concrete Reinforcement AASHTO M 31

Deformed Rail - Steel and Plain

Bars for Concrete Reinforcement ASTM A 616

Deformed A x b - Steel and Plain

Bars for Concrete Reinforcement ASTM A 617

If reinforcing bars are to be welded, these ASTM specifications shall be supplemented by requirements assuring satisfactory weldability.

Bar and rod mats for concrete reinforcement ASTM A 187

Cold-Drawn Steel Wire for concrete reinforcement (ASTM A 82)

AASHTO M 32

Welded steel wire fabric for concrete reinforcement except that (ASTM A 185)

the weld shear strength requirement of those specification shall AASHTO M55

be extended to include a wire size differential up to and including six gages.

Wire and Strands for prestressed concrete ASTM A 416

ASTM A 421

Used in making strands for post-tensioning shall be cold- drawn and either stress-relieved in the case of uncoated strands, or hot dip galvanized in the case of galvanized strands.

High strength alloy steel bar for post- tensioning shall be proof stressed to 90 % of the granted tensile strength. After proof stressing, the bars shall conform to the following minimum properties:

Tensile strength f_s' 1000 MPa

Yield strength (0.2 offset) 0.90 f_s'

Elongation at rupture in 20 diameter 4 percent

Reduction of area at rupture 25 percent

Structural steel ASTM A 36

Steel Pipe for concrete-filled pipe column ASTM A 53

Cast-Iron Pipe for composite columns ASTM A 377

900(7).2.5 Admixtures

Air-entraining admixtures, if used, shall conform to ASTM C 260.

Water-reducing admixtures, retarding admixtures, water-reducing and retarding admixtures and water reducing and accelerating admixtures, if used, shall conform to the requirements of ASTM C 494.

900(7).2.6 Storage of Materials

Cement and aggregates shall be stored in such a manner as to prevent their deterioration or the intrusion of foreign matter. Cement shall be stored, immediately upon arrival on the site of the work, in substantial, waterproof bodegas, with a floor raised from the ground sufficiently high to be free from dampness. Aggregates shall be stored in such a manner as to avoid the inclusion of foreign materials.

900(7).3 Construction Requirements

Notations: The notations used in these regulations are defined as follows:

f'_c = compressive strength of concrete

f_{sp} = ratio of splitting tensile strength to square root of compressive strength.

900(7).3.1 Concrete Quality

All plans submitted for approval or used for any project shall clearly show the specified strength, f_c' , of concrete of the specified age for which each part of the structure was designed.

Concrete that will be exposed to sulfate containing or other chemically aggressive solutions shall be proportioned in accordance with "Recommended Practice for Selecting Proportions for Concrete (ACI 613)" and Recommended Practice for Selecting Proportions for Structural Lightweight Concrete (ACI 613A)."

900.3.2 Methods of Determining the Proportions of Concrete

The determination of the proportions of cement, aggregate, and water to attain the required strengths shall be made by one of the following methods, but lower water-cement ratios may be required for conformance with the quality of concrete.

Method 1, Without preliminary test

Where preliminary test data on the materials to be used in the concrete have not been obtained the water-cement ratio for a given strength of concrete shall not exceed the values shown in Table 900.1. When strengths in excess of 281 kilograms per square centimeter (4000 pounds per square inch) are required or when light weight aggregates or admixtures (other than those exclusively for the purpose of entraining - air) are used, the required water-cement ratio shall be determined in accordance with Method 2.

Method 2. For combination of materials previously evaluated or to be established by trial mixtures.

Water-cement ratios for strengths greater than that shown in Table I 900(7).1 may be used provided that the relationship between strength and water-cement ratio for the materials to be used has been previously established by reliable test data and the resulting concrete satisfies the requirements of concrete quality.

Where previous data are not available. Concrete trial mixtures having proportions and consistency suitable for the work shall be made using at least three different water-cement ratios (or cement content in the case of lightweight aggregates) which will produce a range of strengths encompassing those required for the work. For each water-cement ratio (or cement content) at least three specimens for each age to be tested shall be made, cured and tested for strength in accordance with ASTM C 39 and C 192.

The strength test shall be made at 7, 14 and 28 days at which the concrete is to receive load, as indicated on the plans. A curve shall be established showing the relationship between water-cement ratio (or cement content) and compressive strength. The maximum permissible water-cement ratio for the concrete to be used in the structure shall be that shown by the curve to produce an average strength to satisfy the requirements of the strength test of concrete provided that the water-cement ratio shall be no greater than that required by concrete quality when concrete that is to be subjected to the freezing temperatures which weight shall have a water-cement ratio not exceeding 6 gal per bag and it shall contain entrained air.

Where different materials are to be used for different portions of the work, each combination shall be evaluated separately.

TABLE 900(7).1 MAXIMUM PERMISSIBLE WATER-CEMENT RATIOS FOR CONCRETE (METHOD NO.1)

Specified compressive strength at 28 days, psi f_c'	Maximum permissible water-cement ratio			
	Non air-entrained concrete		Air-entrained concrete	
	U.S. gal. per 42.6 kg. bag of cement	Absolute ratio by weight	U.S. gal per 42.6 kg. bag of cement	Absolute ratio by weight
2500	7 ¼	0.642	6 ¼	0.554
3000	6 ½	0.576	5 ¼	0.465
3500	5 ¾	0.510	4 ½	0.399
4000	5	0.443	4	0.354

900(7).3.3 Concrete Proportions and Consistency

The proportions of aggregate to cement for any concrete shall be such as to produce a mixture which will work readily into the corners and angles of the form and around reinforcement with the method of placing employed on the work, but without permitting the materials to segregate or excess free water to collect on the surface. The methods of measuring concrete materials shall be such that the proportions can be accurately controlled and easily checked at any time during the work.

900(7).3.4 Sampling and Testing of Structural Concrete

As work progresses, at least one (1) set of samples consisting of three (3) concrete cylinder test specimens, 150 x 300 mm shall be taken from each class of concrete placed each day, and each set to represent not more than 75 cu m of concrete.

900(7).3.5 Consistency

Concrete shall have a consistency such that it will be workable in the required position. It shall be such a consistency that it will flow around reinforcing steel but individual particles of the coarse aggregate when isolated shall show a coating or mortar containing its proportionate amount of sand. The consistency of concrete shall be gauged by the ability of the equipment to properly place it and not by the difficulty of mixing water shall be determined by the Engineer and shall not be varied without his consent. Concrete as dry as it is practical to place with the equipment specified shall be used.

900(7).3.6 Strength Test of Concrete

When strength is a basis for acceptance, each class of concrete shall be represented by at least five test (10 specimens). Two specimens shall be made for each test at a given age, and not less than one test shall be made for each 150 cu yd of structural concrete, but there shall be at least one test for each days concreting. The Building Official may require a reasonable number of additional tests during the progress of the work. Samples from which compression test specimens are molded shall be secured in accordance with ASTM C 172. Specimens made to check the adequacy of the proportions for strength of concrete or as a basis for acceptance of concrete shall be made and laboratory-cured in accordance with ASTM C 31. Additional test specimens cured entirely under field conditions may be required by the Building Official to check the adequacy of curing and protection of the concrete. Strength tests shall be made in accordance with ASTM C 39.

The age for strength tests shall be 28 days of, where specified, the earlier age at which the concrete is to receive its full load or maximum stress. Additional test may be made at earlier ages to obtain advance information on the adequacy of strength development where age-strength relationships have been established for the materials and proportions used.

To conform to the requirements of this Item:

- 1) For structures designed in accordance with the working stress design method of this chapter, the average of any five consecutive strength tests of the laboratory-cured specimens representing each class of concrete shall be equal to or greater than the specified strength, f_c' , and not more than 20 percent of the strength test shall have values less than that specified.
- 2) For structures designed in accordance with the ultimate strength design method of this chapter, and for prestressed structures the average of any three consecutive strength test of the laboratory, cured specimens representing each class of concrete shall be equal to or greater than the specified strength, f_c' and not more than 10 percent of the strength tests shall have values less than the specified strength. When it appears that the laboratory-cured specimens will fail to conform to the requirements for strength, the Engineer shall have the right to order changes in the concrete sufficient to increase the strength to meet these requirements. The strengths of the specimens cured on the job are intended to indicate the adequacy of protection and curing of the concrete and may be used to determine when the forms may be stripped, shoring removed, or the structure placed in service. When, in the opinion of the Building Official, the strengths of the job-cured specimens, the contractor may be required to improve the procedures for protecting and curing the concrete, or when test of field-cured cylinders indicate deficiencies in protection and curing, the Engineer may require test in accordance with ASTM Specification C 42 or order load tests as outlined in the load tests of structures for that portion of the structure where the questionable concrete has been placed.

900(7).3.7 Splitting Tensile Test of Concrete

To determine the splitting ratio, F_{sp} , for a particular aggregate, test of concrete shall be made as follows:

1. Twenty-four (24) 15 cm. dia. by 30 cm long (6 in. dia. by 12 in. long) cylinders shall be made in accordance with ASTM C 192, twelve at a compressive strength level of approximately 210 kilograms per square centimeter (3000 psi) and twelve at approximately 280 kilograms per square centimeter (4000 psi) or 350 kilograms per square centimeter (5000 psi). After 7 days moist curing followed by 21 days drying at 23C (73F) and 50 percent relative humidity, eight of the test cylinders at each of the two strength levels shall be tested for splitting strength and four for compressive strength.
2. The splitting tensile strength shall be determined in accordance with ASTM C 496, and compressive strength in accordance with ASTM C 39. The ratio, F_{sp} , of splitting tensile strength to the square root of compressive strength shall be obtained by using the average of all 16 splitting tensile test and all 8 compressive tests. Minimum Strength, Concrete other than fill, shall have a minimum compressive strength at 28 days of 140 kilograms per square centimeter (2000 psi).

900(7).3.8 Batching

Batching shall conform to the requirements of Item 405, Structural Concrete.

900(7).3.9 Mixing and Delivery

Mixing and delivery shall conform to the requirements of Item 405, Structural Concrete.

900(7).4 Concrete Surface Finishing: General

This shall be in accordance with Item 407, Concrete Structures.

900(7).5 Curing Concrete (See subsection 407)

900(7).6 Acceptance of Concrete

The strength of concrete shall be deemed acceptable if the average of 3 consecutive strength test results is equal to or exceed the specified strength and no individual test result falls below the specified strength by more than 15 %.

Concrete deemed to be not acceptable using the above criteria may be rejected unless contractor can provide evidence, by means of core tests, that the quality of concrete represented by the failed test result is acceptable in place. Three (3) cores shall be obtained from the affected area and cured and tested in accordance with AASHTO T24.

Concrete in the area represented by the cores will be deemed acceptable if the average of cores is equal to or at least 85 % and no sample core is less than 75 % of the specified strength otherwise it shall be rejected.

900(7).7 Method of Measurement

The quantity of concrete to be paid shall be the quantity shown in the Bid Schedule, unless changes in design are made in which case the quantity shown in the Bid Schedule will be adjusted by the amount of the change for the purpose of payment. No deduction will be made for the volume occupied by the pipe less than 101 mm (4") in diameter nor for reinforcing steel anchors, weep holes or expansion materials.

900(7).8 Basis of Payment

The accepted quantities of gravel bedding completed in place will be paid for at the contract unit price for cubic meter as indicated on the Bid Schedule.

Pay Item Number	Description	Unit of Measurement
900(7)	REINFORCED CONCRETE (3000 PSI @ 28 DAYS)	Cu.m.

Such prices and payment shall be full compensation for furnishing all materials, including metal water stops, joints, joint fillers, weep holes, and rock backing and timber bumpers; for all form and false work; for mixing, placing, furnishing, and curing the concrete; and for all labor, materials, equipment, tools and incidentals necessary to complete the item, except that reinforcing steel shall be paid for at the contract unit price per kilogram for reinforcing steel metal pipes and drains, metal conduits and ducts, and metal expansion angles shall be paid for as structural steel that when the proposal does not include an item for structural steel these miscellaneous metal parts shall be paid for as reinforcing steel.

ITEM 1046(2)a1 – CHB NON-LOAD BEARING, 100mm (INCLUDING REINFORCING STEEL)

1046(2)a1.1 Description

This item shall consist of the laying of CHB including concrete mortar fill and reinforcing bars to the proposed Repair of Poultry Project Office.

1046(2)a1.2 Method of Measurement

The accepted quantities, measured as prescribed in section 1046(2)a1.1 shall be paid for at the contract unit price for the laying of CHB including concrete mortar fill and reinforcing bars which price and payment shall be full compensation for furnishings and placing all materials, including all labor, equipment, tools, and incidentals necessary to complete the work prescribed in this item.

1046(2)a1.3 Basis of Payment

Payment will be made under:

Pay Item Number	Description	Unit of Measurement
1046(2)a1	CHB NON-LOAD BEARING, 100mm (INCLUDING REINFORCING STEEL)	SQ.M.

ITEM 1027(1) – CEMENT PLASTER FINISH

1027(1). 1 Description

This item shall consist of furnishing all cement plaster materials, labor, tools and equipment required in undertaking cement plaster finish as shown on the Plans and in accordance with this specification.

1027(1). 2 Material Requirements

Manufactured materials shall be delivered in the manufacturer's original unbroken packages or containers which are labelled plainly with the manufacturer's name and trademark.

1027(1). 2.1 Cement

Portland cement shall conform to the requirements as defined in item 700, Hydraulic Cement.

1027(1). 2.2 Hydrated Lime

Hydrated lime shall conform to the requirements as defined in item 701, Hydrated Lime.

1027(1). 2.3 Fine Aggregates

Fine aggregate shall be clean, washed sharp river sand and free from dirt, clay, organic matter or other deleterious substance. Sand derived from crushed gravel or stone may be used with the Engineer's approval but in no case shall such sand be derived from stone unsuitable for use as coarse aggregates.

1027(1). 3 Construction Requirements

1027(1). 3.1 Mixture

- a) Mortar mixture for brown coat shall be freshly prepared and uniformly mixed in the proportion by volume of one part Portland Cement, three (3) parts sand and one fourth (1/4) part hydrated lime.
- b) Finish coat shall be pure Portland Cement properly graded conforming to the requirements of item 700, Hydraulic Cement and mixed with water to approved consistency and plasticity.

1027(1). 3.2 Surface Preparation

- a) After removals of formworks reinforce concrete surfaces shall be roughened to improve adhesion of cement plaster.
- b) Surfaces to receive cement plaster shall be cleaned of all projections, dust, loose particles, grease and bond breakers. Before any application of brown coat is commenced all surfaces that are to be plastered shall be wetted thoroughly with clean water to produce a uniformly moist condition.

1027(1). 3.3 Application

- a) Brown coat mortar mix shall be applied with sufficient pressure starting from the lower portion of the surface to fill the grooved and to prevent air pockets in the reinforced concrete / masonry work and avoid mortar mix drooping. The brown coat shall be lightly broomed/ or scratch before surface had properly set and allowed to cure.
- b) Finish coat shall not be applied until after the brown coat has seasoned for seven days and corrective measures had been done by the contractor on surfaces that are defective. Just before the application of the finish coat, the brown coat surface shall be evenly moistened with potable water. Finish coat shall be floated first to a true and even surface, then troweled in a manner that will force the mixture to penetrate into the brown coat. Surface applied with finish coat shall then be smooth with paper in circular motion to remove trowel marks, checks and blemishes. All cement plaster finish shall be 10mm thick minimum on vertical concrete and/or masonry walls.

Wherever indicated on the plans to be "Simulated Red Brick Finish", the contractor shall render brick design on plaster surface before brown coat had properly set and then allowed to dry. Cement plaster shall not be applied directly to:

- a) Concrete or masonry surface that had been coated with bituminous compound and,
- b) Surfaces that had been painted and previously plastered.

1027(1). 3.4 Workmanship

Cement plaster finish shall be true to details and plumed. Finish surface shall have no visible junction marks where one (1) day's work adjoins the other. Where directed by the Engineer or as shown on the plans vertical and horizontal groove joints shall be 25 mm wide and 10 mm deep.

1027(1). 4 Method of Measurement

All cement plaster finish shall be measured in square meters or part thereof for work actually completed in the building.

1027(1). 5 Basis of Payment

The work quantified and determined as provided in the Bill of Quantities shall be paid for at the contract unit price which price constitutes full compensation including labor, materials, tools and equipment and incidentals necessary to complete this item.

Payment will be made under:

Pay Item Number	Description	Unit of Measurement
1027(1)	CEMENT PLASTER FINISH	SQ.M.

ITEM 1021(1)a - CEMENT FLOOR FINISH (PLAIN)

1021(1)a.1 Description

This Item shall consist of furnishing all materials, labor, tools and equipment in undertaking cement floor finishing were shown on the Plans and in accordance with this Specification.

1021(1)a.2 Material Requirements

Manufactured materials shall be delivered in the manufacturer's original unbroken packages or containers which are labeled plainly with the manufacturer's name and trademark.

1021(1)a.2.1 Cement

Portland cement shall conform to the requirement of Item 700, Hydraulic Cement.

1021(1)a.2.2 Fine Aggregates

Fine aggregates shall be clean, washed, Sharp River sand and free from dirt, clay, organic matter or other deleterious substances. Sand derived from crushed gravel or stone may be used with the Engineer's approval but in no case shall such sand be derived from stone unsuitable for use as coarse aggregate.

1021(1)a.2.3 Coloring Material

The coloring material shall be red or green oxide powder of the quality capable of achieving the best staining power and homogeneity.

1021(1)a.2.4 Metallic Floor Hardener (Premix)

Metallic floor hardener shall be a mixture of oil-free specially graded clean iron particles, mineral oxide pigment and Portland cement binder, premixed according to the manufacturer's instruction manual.

Non-Metallic Floor Hardener

- a) Powder type hardener shall be silica quartz aggregates, workability admixtures, mineral oxide pigments and Portland cement mixed according to the manufacturer's instruction manual.
- b) Epoxy type topping hardener shall be a combination of epoxy resins filled with hard and natural emery or silica quartz aggregates, premixed according to the manufacturer's instruction manual.

1021(1)a.3 Construction Requirements

1021(1)a.3.1 Mixture

Concrete topping materials shall be measured accurately in accordance with the following:

- a) Mortar topping shall be one (1) part Portland cement and three (3) parts fine aggregate by loose volume.
- b) Finish topping shall be pure Portland cement properly graded conforming to the requirements of Item 700, Hydraulic Cement, mixed with water to approved consistency and plasticity. Where required to be colored cement floor finish, red or green oxide powder shall be premixed with Portland cement complying with finish topping requirements and the desired color intensity. Cement floor finish floor hardener shall be premixed as required and applied in accordance with the manufacturer's instruction manual.

1021(1)a.3.2 Preparation of Concrete Surface

Surface to receive mortar concrete topping shall be cleaned of all projections, dust, loose particles and other foreign matters.

Finish elevation shall be established over the areas indicated on the Plans.

1021(1)a.3.3 Application

Before any mortar concrete topping is applied, the prepared concrete base surface shall first be wetted and grouted with Portland cement.

- a) Mortar topping of the thickness specified on the Plans, shall be spread over the prepared concrete base and shall be float finished using wood hand trowel. Batches of mortar topping shall be emplaced within one hour of mixing thereof.
- b) As soon as the water sheen has disappeared the surface shall be lightly scratched with a stiff bristle broom

- c) The finish topping mixture whether plain, colored, or with floor hardener shall be spread over the lightly scratched surface before final set taken place and hand troweled to produce a smooth surface.
- d) The finished surface shall be free of trowel marks, have uniform texture and true to a plane within an allowable tolerance of 3 mm in 3.0 meters.

1021(1)a.3.4 Protection of Finished Surface

Cement floor finished surface shall be covered with burlap or appropriate covering to avoid injurious action by sun, rain, flowing water and mechanical injury.

1021(1)a.3.5 Workmanship

Cement floor shall be finished level and true to finish elevation as shown on the Plans Finish topping shall have no visible junction marks where one (1) day's work adjoins the other. V-cut groove lines shall be provided where shown on the Plans or as directed by the Engineer.

1021(1)a.4 Method of Measurement

All cement floor finish shall be measured in square meters or part thereof for work actually completed and accepted.

1021(1)a.5 Basis of Payment

The work actually completed and accepted as measured in square meters shall be paid for at the Unit Price or contract price which price constitute full compensation including labor, materials, tools and incidentals necessary to complete this Item.

Payment shall be made under:

Pay Item Number	Description	Unit of Measurement
1021(1)a	CEMENT FLOOR FINISH (PLAIN)	SQ.M.

ITEM 1003 - METAL STUD DRYWALL

1003.1 Description of Work

The work under this Item shall consist of furnish all labor, materials and equipment necessary to complete entire metal stud partition system as indicated on the Drawings and finish schedule and herein specified.

1003.2 Material Requirements

1003.2.1 Materials

- A. Studs shall be 3-5/8 in. wide metal "C" studs, roll-formed from 20-gage galvanized steel, designed for screw attachment, in lengths indicated on the drawings.
 - 1. Studs shall not be spliced, but shall be transported to the partition location in lengths shown on the Drawings.
 - 2. Contractor shall submit method of how to get the studs into the basement, for approval by the Engineer, since basement access is limited.
- B. Bottom runner and ceiling track shall be metal runners formed of galvanized steel, and in sizes to correspond with the studs. Ceiling tracks shall be galvanized steel, with slotted vertical holes, to allow deflection of the ceiling above, as the floor above takes live load.
- C. Metal studs, runners, tracks, and all framing, shall be all from one manufacturer.
 - 1. Acceptable manufacturers: Marino \ WARE, LLC, South Plainfield, NJ 07080, or equal.
- D. Wallboard shall have eased radial edges specially designed to overcome joint deformation, shall comply with Federal Specifications SS1-30c and ASTM C36, and shall be:
- E. Wallboard sealant shall be sheetrock Brand W/R sealant.
- F. Fasteners, for wallboard shall be 7/8 in. Brand HI-LO type S Bugle Head Screws.
- G. Fasteners, for stud to runner shall be 3/8 in. Brand Type S Fan Head Screws.
- H. Fasteners, for stud to door frame shall be 1/2-inch Brand Type S-12 Fan Head Screws.
- I. Metal trim shall be galvanized, of sizes corresponding with the wallboard thickness and types as detailed on the drawings.
- J. Caulking shall be a resilient, non-hardening, non- shrinking, non-skinning, non-straining material.

1003.2.2 Anchorage of Framing to Concrete and Grouted Masonry

- A. Steel framing shall be secured to concrete and grouted masonry as shown on the Drawings.
 - 1. Anchors shall be ITW Buildex "Tapcon" Concrete Screws, or equal. Install in strict accordance with manufacturer's printed instructions.

1003.3 Installation

- A. Metal runners shall be aligned accurately according to partition layouts and secured to perimeter surfaces as shown on the Drawings.

- B. Metals studs shall be placed as spacing shown on the Drawings. All studs shall span full height, in one piece, with no splices. Pipe or conduit chases may be provided by cutting round holes in the center of the stud web, spaced at least 12 in. apart, and no larger than 75% of the stud width.
- C. Unless shown otherwise on the Drawings, metal door frame studs shall be located within 2 in. of all door-frame jambs and shall be anchored to the jamb and head anchor clips of each frame by bolt or screw attachment.
- D. All metal door frames shall be spot grouted at the jamb anchor clips, after the stud and before the gypsum wallboard is installed.
- E. Wallboard screws shall be applied with an electric screw gun. Screws shall be driven not less than 3/8 in. from ends or edges of wallboard to provide uniform dimple not over 1/32 in. deep.
- F. Vertical wallboard shall be fastened to web of corner runner and flange of ceiling runner with 1-inch screws spaced 12 in. o.c. Studs shall be inserted between corner runner and wall runner. Alternate studs shall be attached to runners with USG Metal Lock Fastener Tool. Bottom wallboard shall be attached to studs and runners with 1-in. screws spaced 12 in. o.c. Screws in the corner runner shall be located at least 1-in. from the edge of the wallboard.
- G. Accessories
 - 1. Corner beads shall be installed on all exterior corners, attached with suitable fasteners spaced 9 in. o.c. on both sides, and shall be in single lengths unless corner length exceeds standard stock lengths.
 - 2. Control joints shall be installed where indicated, and as detailed, on the Drawings.
 - 3. See Drawings for any other accessories.
- H. Joint treatment compounds shall be mixed according to manufacturer's directions.

1. Pre-filling

All "V" grooves formed by abutting eased radial edges of wallboard shall be filled flush with the plane of the taper with pre-fill compound. Excess compound beyond the "V" groove shall be wiped clean leaving a flat joint to receive the taping.

2. Taping

After pre-fill has hardened, a thin, uniform layer of taping compound shall be applied to all joints and angles to be reinforced. Reinforcing tape shall be applied immediately, centered over the joint, seated into the compound. A skim coat shall follow immediately, but shall not function as a fill or second coat. Tape shall be properly folded and embedded in all angles to provide a true angle.

3. Filling

After taping compound has hardened, topping compound shall be applied, filling the board taper flush with the surface. The fill coat shall cover the tape and feather out slightly beyond the tape. On joints with no taper, the fill coat shall cover the tape and feather out at least 4 in. on either side of the tape. No fill coat is necessary on interior angles.

4. Finishing

After topping compound is set, a finishing coat of topping compound shall be spread evenly over and extending slightly beyond the fill coat on all joints and feathered to a smooth, uniform finish. Over tapered edges, the finished joint shall not protrude beyond the plane of the surface. All taped angles shall receive a finish coat to cover the tape and taping compound, and provide a true angle. Where necessary, sanding shall be done between coats and following the final application of compound to provide a smooth surface, ready for decoration.

I. Fastener Depressions

Taping compound shall be applied to all fastener depressions followed, when hardened, by at least two coats of topping compound, leaving all depressions level with the plane of the surface.

J. Finishing Beads and Trim

Taping compound shall be applied to all bead and trim and shall be feathered out from the ground to the plane of the surface. When hardened, this shall be followed by two coats of topping compound each extending slightly beyond the previous coat. The finish coat shall be feathered from the ground to the plane of the surface and sanded as necessary to provide a flat, smooth surface ready for decoration.

1003.4 Cleaning

At the completion of installation of the partitions, all rubbish shall be removed from the building, leaving floors broom clean. Excess material, scaffolding, tools, and other equipment shall be removed from the building and job site.

1003.5 Basis of Payment

Payment will be made under:

Pay Item Number	Description	Unit of Measurement
1003	METAL STUD DRYWALL	SQ.M.

ITEM SPL. 3 – ALUMINUM FRAMED GLASS WINDOWS

SPL.3.1 Description

This Item shall consist of all fabricated steel windows fully equipped with fixing accessories and locking devices as shown on the Plans and in accordance with this Specification.

SPL.3.2 Material Requirements

All members shall be of hot-rolled, low carbon, new billet steel, heavy section with depth of at least 33mm and web thickness of at least 3mm. Frame members shall be of equal leg design section only at points were called for or shown on detailed drawings. Continuous angle fins, as indicated shall be furnished. Zee type section of special design with offset permitting down turned leg of the ventilator member to seat flush when ventilator is in a fully closed position, shall be used for frame at sills. Ventilator members shall be special angle shape. Frames of ventilator members shall have integral weather baffles providing double flat parallel weathering contacts of not less than 6mm width on all four sides of the ventilator. Muntin's shall be 25mm by 25mm rolled-tee sections. All members to be used shall conform to the specification requirements of ASTM A "505. The frame member shall afford not less than 16mm continuous anchorage to surrounding masonry. Unless otherwise specified/or indicated on Plan as residential casement, special size of section shall be used.

SPL.3.2.1 Residential Casement

Sections shall be hot rolled new billet steel special design. Frame and ventilator members shall be specially designed zee sections, not less than 25 mm in depth and not less than 3 mm in thickness, with weathering baffles rolled integrally to provide continuous double contact between frame and casement ventilator members. Muntin's shall be 19mm by 19 mm rolled tee-sections. Side hung hinges shall be of extension friction type welded to both frame and ventilator with friction washers and steel acorn-nuts.

SPL.3.2.2 Heavy Duty Side-hinged Ventilator

Frame and ventilator members shall be specially designed zee section not less than 33 mm in depth and not less than 3 mm in thickness, with weathering baffles rolled integrally to provide continuous double contact between frame and side-hinged ventilator members. Muntin shall be 25 mm by 25 mm rolled tee-sections. Simplex-type hinges shall be of extension friction type with bronze friction washers and rust proofed steel acorn-nuts., hinged design shall provide ferrous to non ferrous contacts between all movable surfaces. Hinges shall be welded to both frame and ventilator.

SPL.3.2.3 Projected Ventilators

All members shall be hot rolled new billet steel window. Frames and ventilator sections shall be special angle shape and not less than 33 mm deep from front to back not less than 3 mm in thickness. Weathering projections, overlapping, parallel contacts at both insides and outside points of closure on all four sides of the ventilator shall be 6 mm.

SPL.3.2.4 Awning ventilators (for series of ventilators operating simultaneously)

Frame, ventilator and muntin members shall be hot rolled new billet steel section not less than 33 mm deep, specifically designed for steel windows.

SPL.3.3 Construction Requirements

SPL.3.3.1 Fabrication and Welds

Corners of frame and ventilator shall be mitered and electrically butt welded with exposed welds ground smooth. Head drips shall be provided where ventilator extend to the top of the windows. Muntin's shall be welded to frames. Muntin intersections shall be welded with flush interior surfaces

SPL.3.3.2 Hardware (fixing accessories and locking devices)

SPL.3.3.2.1 Residential Casement, heavy duty side-hinged ventilator

- a) Roto Type: Each ventilator shall be hung on two heavy hot rolled steel of the extension type, welded to both frame and ventilator. Hinged design shall provide ferrous to nonferrous to non ferrous contacts between all movable surfaces. Hardware shall control ventilator independently of the screen and shall consist of a polished bronze locking handle and worn drive operator. Provide however that roto hardware shall not be used on any ventilator, the size of which exceeds 1 square meter in area. Ventilators over 150 mm in height shall have three (3) hinges and double locking device.
- b) Simplex-Type: Hinges shall be of extension friction type with bronze friction washers and rust proofed steel acorn-nuts. Hinged design shall provide ferrous to non ferrous contacts between all movable surfaces. Hinges shall be welded to both frame and ventilator.
- c) Polished bronze locking handle and strike shall be furnished for ventilator 500 mm and under in height, two point locking devices and three (3) hinges for ventilators over 500 mm in height. Sill adjuster shall be provided for ventilator over 1000 mm square meter in area.

SPL.3.3.2.2 Projected Ventilators

Each ventilator shall be balanced on two heavy steel arms riveted to ventilator -and frame. Rivet holes in arms shall be bronze bushed. Uniform tension to hold ventilator in open position shall be obtained by two heavy bronze, sliding friction shoes with adjustable compression springs enclosed in bronze housing attached to the ventilator top rail member. The window frame member shall act as a guide for the friction shoe.

Hardware shall consist of polished bronze pole hook ring, cam handle and strike for outward projecting ventilators. Polished bronze, pole operated spring latches, shall be substituted for locking handles on outward projecting ventilator, out of each floor, polished bronze, cord operated, spring latches for inward projecting vents not within reach of floor provided with double line of best quality sash cord 5 mm to 6 mm in diameter extending to 762 mm above floor. Polished bronze, under screen push bar working through the member to be furnished for outward projecting ventilator when so indicated on Plans or drawings.

SPL.3.3.2.3 Awning Ventilators

Each awning window so indicated on the Plans shall be of the awning type window in which the ventilators operate simultaneously and controlled manually. Each projecting ventilator shall be balanced on two heavy steel supporting arms. Arms for upper ventilators shall have tops pivots enclosed in malleable iron housing riveted to ventilator and pivoting point shall be located outside of window to provide efficient leverage. Ventilator in each window shall be equipped with extension arms attached to connecting steel frame and shall be concealed within frame when ventilators are in closed position. All ventilators shall open or close simultaneously. The bottom ventilator shall be the means of control and shall be fitted with a solid bronze, polished, cam locking handle and strike. Base of handle to dowel with strike to prevent side motion of ventilator. Where windows are screened, provide a bronze under screen push bar working thru the frame member.

SPL.3.3.3 Installation

All steel windows shall be set plumb and true in openings. The joints between the window frame and masonry shall be carefully caulked. Contacts between windows or doors and adjacent steel including mullions shall be sealed with mastic furnished and applied by the Contractor. Windows shall be designed for glazing from the outside with spring wire glazing clips and glazing putty.

Mullions and anchors shall be manufacturer's standard, vertical mullions, anchors and bolts for attaching shall be furnished where required.

Adequate anchorage shall be provided to ensure firm installation.

SPL.3.3.4 Shop Painting

All windows shall be given a coating of gray metallic paint applied to all surfaces as paint base for prevention of corrosion. Prior to application of paint primer the steel sections shall be cleaned of rust, oil, grease and other foreign matter.

SPL.3.4 Method of Measurement

Steel windows shall be measured by actual in place installed with respective design/style and type of operation in square meters.

SPL.3.5 Basis of Payment

The actual area in square meters of steel windows satisfactorily installed and ready for service shall be the basis for payment based on the unit bid or contract unit price.

Payment shall be made under:

Pay Item Number	Description	Unit of Measurement
SPL.3	ALUMINUM FRAMED GLASS WINDOWS	LUMP SUM

ITEM SPL.2 – DOORS (INCLUDING JAMBS AND COMPLETE ACCESSORIES)

SPL.2.1 Description

This Item shall consist of furnishing and installing all fabricated steel doors and frames equipped with fixing accessories and locking devices in accordance with the Plans and/or shop drawings and as herein specified.

SPL.2.2 Material Requirements

All door cladding plates or panels shall be formed from gauge 20 cold-rolled, prime quality steel. Frames shall be formed from gauge 16 cold-rolled steel. The materials used shall conform to the specification requirement of ASTM-A505.

SPL.2.2.1 Tubular Door (Casement/Sliding)

- a) Hollow steel doors shall be custom built of size and details as indicated on the Plans and/or shop drawings. Cladding of doors shall be flush or louver type. Doors shall be 44 mm thick, side hinged or overhead hung, as called for on the Plans.
- b) Flush doors shall be constructed from two outer steel sheets not lighter than gauge 20, with edges welded and finished flush. The outer face sheets shall be reinforced with gauge 24 vertical channels or interlocking zee members. Sound insulation fillers of cork fiberboard, mineral wool board or asbestos shall be placed full height in spaces between reinforcing channels. Doors

shall have smooth, flush surfaces without any visible joints or seams on exposed faces or stile edges except around glazed or louvered pane inserts. Top and bottom frame of doors shall have continuous reinforcing channels welded to face sheets. The channel for exterior doors shall be inverted type, not lighter than gauge 16, constructed to form a weather seal. Glazed opening shall be provided where indicated and molding around glazed openings shall not be lighter than gauge 20 metal.

SPL.2.2.2 Grille doors shall be of flat, square or round bars (wrought iron) as indicated on the Plans framed on galvanized black iron pipe or flat wrought iron bars, of the design shown on the Plans.

SPL.2.2.3 Tubular steel frames shall be machine pressed true to details, to size and shape as shown on the Plans and shall have full welded unit or knockdown field assembled type construction at corners and other joints.

SPL.2.2.4 Steel Louvers

Louvers shall be machine pressed conforming to the size and design indicated on the Plans with removable louver pane formed to fit the metal sub frame of openings. The steel sheets shall meet the requirement of ASTM 505, rivets of ASTM B 316, screws, bolts, nuts and washers of ASTM B 211.

SPL.2.2.5 Anchors and Fasteners

Anchors shall be steel, zinc coated or coated or painted with rust inhibitive paint, of sizes, shapes and design per manufacturer's standards.

Floor anchors shall not be lighter than gauge 18, with exception of jamb anchors for installing door frames in metal latch and plaster assemblies which shall be minimum of gauge 16 and shall not extend no more than 20 mm out of the back of the jamb.

SPL.2.3 Construction Requirements

SPL.2.3.1 Fabrication

Corner joints of frames shall be mitered and welded conforming to manufacturer's standard manual for metal doors. All contact edges be closed tight. Welds on exposed surface shall be ground smooth and shall be neat in appearance.

Joints for knock-down type frame corners shall be designed for simple field assembly of header to jamb members by concealed tenon, splice plates, or other type concealed in interlocking joint that will produce square and rigid corners. Joints shall be securely locked in place during erection and the alignment of adjoining members shall be maintained. All bolted connections shall be provided with lock units.

SPL.2.3.2 Shop Finish

a. Hot or Cold Phosphate Surface Treatment

All steel doors, frames and louvers shall be cleaned thoroughly, phosphate-treated to assure maximum paint adherence and prime finish, in accordance with the following operations:

- 1) After fabrication, grease and dirt shall be removed by a hot alkali solution and rinsed with hot water.
- 2) After cleaning, all parts shall be immersed in hot or cold phosphate solution and rinsed with a diluted solution or chronic acid.
- 3) After drying under controlled temperature, one coat of shop primer shall be applied by dipping type especially developed for materials treated with phosphates.

The cleaning, phosphate, dipping or spraying of shop primer and even drying shall be done on a continuous operation in the factory.

SPL.2.3.3 Installation

Steel doors, frames and louvers shall be set plumb and true in 'The joint between frame and masonry shall be carefully contacts between door/frame and adjacent steel shall be sealed with mastic.

SPL.2.3.4 Wall Anchors

A minimum of three anchors shall be provided for each jamb. Anchors shall be located opposite the top and bottom hinges and midway between top and bottom anchors.

Anchors for fastening frames to masonry shall be adjustable, and perforated and shall extend not less than 200 mm into masonry.

Anchors for fastening frames to metal or wood stud partitions shall be welded to metal or nailed to wood studs respectively.

Anchors for fastening frames to previously placed concrete or masonry shall be secured to existing construction with expansion bolts. Frames shall be fastened securely with anchors.

Anchors for fastening frames to partitions of plaster on metal lathe shall be secured firmly to back of frames that shall receive the latch. Adjustable strut anchors shall be provided on each side of frame for fastening to the structural members of the partition and of the ceiling framing above. The size and type of strut anchors shall be as recommended by the metal door manufacturer.

SPL.2.3.5 Floor Anchors

Floor anchors shall be provided at the bottom of each jamb member, anchors shall be fixed/adjustable and drilled for 10mm diameter anchor bolts.

Where floor fill occurs, the bottom of frames shall terminate at the indicated finished floor levels and shall be supported by adjustable extension clips resting on and anchored to the structural slab.

SPL.2.3.6 Hardware

Side bronze butts for side hung doors, overhead pocket hardware for track and roller types and locksets shall be suitable for the service required and subject to the approval of the Engineer and as provided in Item 1004, Hardware.

SPL.2.4 Method of Measurement

Steel doors, frames, louvers, accessories and hardware shall be measured in square meters/per set as shown on the Plans. A set shall consist of metal door, jambs, anchors and hardware except locksets.

SPL.2.5 Basis of Payment

The area in m2 for every hollow steel door, flush door, grille door and steel louver installed ready for service shall be the basis of payment based on the unit bid or contract unit price

Payment will be made under:

Pay Item Number	Description	Unit of Measurement
SPL.2	DOORS (INCLUDING JAMBS ANND COMPLETE ACCESSORIES	LUMP SUM

ITEM 1018 - CERAMIC TILES

1018.1 Description

This Item shall consist of furnishing all ceramic tiles and cementitious materials, tools and equipment including labor required in undertaking the proper installation of walls and floor tiles as shown on the Plans and in accordance with this Specification.

1018.2 Material Requirements

1018.2.1 Ceramic tiles and trims shall be made of clay, or a mixture of clay and other materials which is called the body of the tile. Tile bodies are classified by ASTM C 242 as to their degree of water absorption. Ceramic tiles and trims are manufactured either by dust-pressed process in which the clays are ground to dust mixed with a minimum of water shaped in steel dies and then fired or by plastic process in which the clays are made plastic by mixing with water, shaped by extrusion or in molds and then fired.

1018.2.1.1 Glazed Tiles and Trims

Glazed tiles' and trims shall have an impervious face of ceramic materials fused onto the body of the tiles and trims. The glazed surface may be clear white or colored depending on the color scheme approved by the Engineer. Standard glazes may be bright (glossy) semimatte (Less glossy) matte (dull) or crystalline (mottled and textured; good resistance to abrasion). Glazed tiles are used principally for walls; crystalline glazed tiles may be used for floors provided however that these are used as light duty floors.

1018.2.1.2 Unglazed Tiles

Unglazed tiles shall be hard dense tile of homogeneous composition.

Its color and characteristics are determined by the materials used in the body, the method of manufacture and the thermal treatment. It is used primarily for floors and walks.

1018.2.1.3 Trims

Trims are manufactured to match wall tile color, texture and to coordinate with it in dimension. These are shaped in various ceramic trim units such as caps, bases, coves, bullnoses, corners, angles, etc. That are necessary for edging or making a transition between intersecting planes.

1018.2.1.4 Accessories

Accessories like some soap holders and shall be made wall mounted type with colors to reconcile with the color of the adjacent wall tiles.

1018.2.1.5 Cement

Cement shall be Portland conforming to the specification requirements defined in Item 700, Hydraulic Cement.

1018.2.1.6 Sand

Sand shall be well graded fine aggregate clean river sand, free from soluble salts and organic impurities.

1018.2.1.7 Lime

Lime shall be hydrated lime with free unhydrated oxide and magnesium oxide content not to exceed 8 percent by weight.

1018.3 Construction Requirements

Tile work shall not be started until roughing-ins for plumbing, electrical and other trades have been completed and tested. The work of all other trades shall be protected from damage.

1018.3.1 Surface Preparation

a) Mortar mix for scratch coat and setting bed shall consist of one part Portland cement 1/4 part lime and 3 parts sand by volume. Surface to receive tile must be level, true to elevation, dry, free from dirt, oil and other ointments. Allow at least seven days curing of scratch coat and setting bed.

Installation work shall not be allowed to proceed until unsatisfactory conditions are corrected.

b) Bond coat shall be portland cement paste.

1018.3.1.1 Thoroughly dampen surfaces of masonry or concrete walls before scratch coat is applied.

1018.3.1.2 On masonry or concrete surface first apply a thin coat with pressure, then bring it out sufficiently to compensate for the major irregularities of the surface to a thickness not less than 10 mm. at any point.

1018.3.1.3 Evenly rate scratch coat to provide good mechanical key before the mortar mix has fully hardened.

1018.3.2 Installation Procedure

Ceramic tiles shall be soaked in clean water prior to installation for a minimum of one hour

1018.3.2.1 Ceramic Glazed Wall Tiles

- a) Determine and mark layout of ceramic tiles, joint location, position of trims and fixtures so as to minimize cut less than one-half tile in size.
- b) Thoroughly dampen surface of wall but do not saturate surface.
- c) Apply a bond coat mix with consistency of cream paste 1.5 mm thick to the wall surface or to the back of the tile to be laid.
- d) Lay the tiles true to profile then exert pressure and tamp tile surface before the bond coat mix has initially set.
- e) Continue with the next full tile to be laid and pressed firmly upon the setting bed tamped until flush and in place of the other tiles.
- f) Intersections and returns shall be formed accurately using the appropriate trims.
- g) All lines shall be kept straight and true to profiles, plumbed and internal corners rounded using the appropriate trims.

1018.3.2.2 Vitrified Unglazed Floor Tiles

- a) Before tire is applied the floor surface shall be tested for levelness or uniformity of slope by flooding it with water. Area where water ponds are filled or levelled, shall be retested before the setting bed is applied.
- b) Establish lines of borders and center of the walls at the field work in both direction to perhit the pattern to be laid with a minimum of cut tiles.
- c) Clean concrete subfloor then moisten but do not soak. Then sprinkle dry cement over the surface and spread the mortar on the setting bed.
- d) Apply and spread mortar mix for setting bed and tamp to assure good bond over the entire area to be laid with tile.
- e) Pitch floor to drain as shown on Plans or as directed by the Engineer
- f) Allow the setting bed to set sufficiently to be worked over then spread a bond coat over the surface and lay tile in accordance with Items 1019'.3.2.1 a, b, c,d, e, f, g.

1018.3.3 Grouting and Pointing

1018.3.3.1 Tiles shall have laid in place for at least 24 hours before grouting of the joints is started. Grouting mortar shall be white Portland cement or blended with pigments to acquire the color appropriate for the ceramic tile.

1018.3.3.2 Grouting mortar shall be applied over the tile by float or squeegee stroked diagonally across the joints. Remove excess mortar with a wet sponge stroked diagonally or in a circular motion after 12-15 minutes. Follow with a barely damp or dry sponge to remove remaining haze while smoothing all grouted joints.

1018.3.3 Cleaning

- a) Clean ceramic tile surfaces thoroughly as possible upon completion of grouting.
- b) Remove all grout haze, observing tile manufacturers recommendations as to use of acid or chemical cleaners.
- c) Rinse tile thoroughly with clean water before and after using chemical cleaners.
- d) Polish surface of tile with soft cloth.

1018.3.4 Protection from Construction Dirt

- a) Apply a protective coat of neutral cleanser solution diluted with water in the proportion of 1:4 or 1 liter cleanser concentrate to 1 gallon water.
- b) In addition, cover tile flooring with heavy-duty no staining construction paper, taped in place.

- c) Just before final acceptance of the work remove paper and rinse protective coat of neutral cleaner from tile surface. Do not let protective paper get torn or removed.

1018.4 Method of Measurement

All works performed under this Item shall be measured in square meters for areas actually laid with ceramic tiles and accepted to the satisfaction of the Engineer.

1018.5 Basis of Payment

Ceramic tile work determined and provided in the Bill of Bill of Quantities shall be paid for based at the unit bid price which price and payment constitute full compensation for furnishing all materials, tools, equipment and other incidentals necessary to complete this Item.

Payment shall be made under:

Pay Item Number	Description	Unit of Measurement
1018	CERAMIC TILES	SQ.M.

ITEM 1032 – PAINTING WORKS (MASONRY/CONCRETE, WOOD, STEEL)

1032.1 Description

This Item shall consist of furnishing all paint materials, varnish and other related products, labor, tools, equipment and plant required in undertaking the proper application of painting, varnishing and related works indicated on the Plans and in accordance with this Specification.

1032.2 Material Requirements

1032.2.1 Paint Materials

All types of paint material, varnish and other related product shall be subject to random test as to material composition by the Bureau of Research and Standard, DPWH or the National Institute of Science and Technology. (Use the following approved and tested brand name: Boysen, Davies, Dutch Boy, Fuller 0 Brien, or any approved equal).

1032.2.2 Tinting Colors

Tinting colors shall be first grade quality, pigment ground in alkyd resin that disperses and mixes easily with paint to produce the color desired. Use the same brand of paint and tinting color to effect good paint body.

1032.2.3 Concrete Neutralizer

Concrete neutralizer shall be first grade quality concentrate diluted with clean water and applied as surface conditioner of new interior and exterior walls thus improving paint adhesion and durability.

1032.2.4 Silicon Water Repellant

Silicon water repellant shall be transparent water shield especially formulated to repel rain and moisture on exterior masonry surfaces.

1032.2.5 Patching Compound

Patching compound shall be fine powder type material like calciumine that can be mixed into putty consistency, with oil base primers and paints to fill minor surface dents and imperfections.

1032.2.6 Varnish

Varnish shall be a homogeneous solution of resin, drying oil, drier and solvent. It shall be extremely durable clear coating, highly resistant to wear and tear without cracking, peeling, whitening, spotting, etc. with minimum loss of gloss for a maximum period of time.

1032.2.7 Lacquer

Lacquer shall be any type of organic coating that dries rapidly and solely by evaporation of the solvent. Typical solvent are acetates, alcohols and ketones. Although lacquers were generally based on nitrocellulose, manufacturers currently use, vinyl resins, plasticizers and reacted drying oils to improve adhesion and elasticity.

1032.2.8 Shellac

Shellac shall be a solution of refined lac resin in denatured alcohol. It dries by evaporation of the alcohol. The resin is generally furnished in orange and bleached grades.

1032.2.9 Sanding Sealer

Sanding sealer shall be quick drying lacquer, formulated to provide quick dry, good holdout of succeeding coats, and containing sanding agents such as zinc stearate to allow dry sanding of sealer.

1032.2.10 Glazing Putty

Glazing putty shall be alkyd-type product for filling minor surface unevenness.

1032.2.11 Natural Wood Paste Filler

Wood paste filler shall be quality filler for filling and sealing open grain of interior wood. It shall produce a level finish for following coats of paint varnish/lacquer and other related products.

1032.2.12 Schedule

Exterior

- | | |
|--|--|
| a) Plain cement plastered finish to be painted | -3 coats Acrylic base masonry paint |
| b) Concrete exposed aggregate and/or tool finish | -1 coat water repellent |
| c) Ferrous metal | -1 coat primer and 2 coats enamel paint |
| d) Galvanized metal | -1 coat zinc chromate primer and 2 coats portland cement paint |
| e) Wood painted finish | -3 coats oil based paint |
| f) Wood varnished finish | -varnish water repellent |

Interior

- | | |
|--|--|
| a) Plain cement plastered finish to be painted | - 2 coats acrylic base masonry paint |
| b) Concrete exposed aggregate and/or tool finish | - clean surface |
| c) Ferrous metal | -1 coat primer and 2 coats enamel paint |
| d) Woodwork sea-mist | -3 coats of 3 parts thinner 1 part lacquer |
| e) Woodwork varnish | - 1st coat, of one part sanding sealer to one part solvent 2nd coat of 2/3 sanding sealer to 1/3 solvent |
| f) Woodwork painted | - 3 coats of oil base paint finish 109 |
| g) Ceiling boards textured finish paint coat | -1 coat oil based paint allow to dry then patch surfaces unevenness and apply textured paint coat |

1032.3 Construction Requirements

The Contractor prior to commencement of the painting, varnishing and related work shall examine the surfaces to be applied in order not to jeopardize the quality and appearances of the painting varnishing and related works.

1032.3.1 Surface Preparation

All surfaces shall be in proper condition to receive the finish. Woodworks shall be hand-sanded smooth and dusted clean. All knotholes pitch pockets or sappy portions shall be sealed with natural wood filler. Nail holes, cracks or defects shall be carefully puttied after the first coat, matching the color of paint.

Interior woodworks shall be sandpapered between coats. Cracks, holes or imperfections in plaster shall be filled with patching compound and smoothed off to match adjoining surfaces.

Concrete and masonry surfaces shall be coated with concrete neutralizer and allowed to dry before any painting primer coat is applied. When surface is dried apply first coating. Hairline cracks and unevenness shall be patched and sealed with approved putty or patching compound. After all defects are corrected apply the finish coats as specified on the Plans (color scheme approved).

Metal shall be clean, dry and free from mill scale and rust. Remove all grease and oil from surfaces. Wash unprimed galvanized metal with etching solution and allow it to dry. Where required to prime coat surface with Red Lead Primer same shall be approved by the Engineer.

In addition, the Contractor shall undertake the following:

1. Voids, cracks, nick etc. will be repaired with proper patching material and finished flush with surrounding surfaces.
2. Marred or damaged shop coats on metal shall be spot primed with appropriate metal primer.
3. Painting and varnishing works shall not be commenced when it is too hot or cold.
4. Allow appropriate ventilation during application and drying period.
5. All hardware will be fitted and removed or protected prior to painting and varnishing works.

1032.3.2 Application

Paints when applied by brush shall become non-fluid, thick enough to lay down as adequate film of wet paint. Brush marks shall flow out after application of paint.

Paints made for application by roller must be similar to brushing paint. It must be nonstick when thinned to spraying viscosity so that it will break up easily into droplets.

Paint is atomized by high pressure pumping rather than broken up by the large volume of air mixed with it. These procedures change the required properties of the paint.

1032.3.3 Mixing and Thinning

At the time of application paint shall show no sign of deterioration. Paint shall be thoroughly stirred, strained and kept at a uniform consistency during application. Paints of different manufacture shall not be mixed together. When thinning is necessary, this may be done immediately prior to application in accordance with the manufacturer's directions, but not in excess of 1 pint of suitable thinner per gallon of the paint.

1032.3.4 Storage

All material to be used under this Item shall be stored in a single place to be designated by the Engineer and such place shall be kept neat and clean at all time. Necessary precaution to avoid fire must be observed by removing oily rags, waste, etc. at the end of daily work.

1032.3.5 Cleaning

All cloths and cotton waste which constitute fire hazards shall be placed in metal containers or destroyed at the end of daily works. Upon completion of the work, all staging, scaffolding and paint containers shall be removed. Paint drips, oil, or stains on adjacent surfaces shall be removed and the entire job left clean and acceptable to the Engineer.

1032.3.6 Workmanship in General

- a) All paints shall be evenly applied. Coats shall be of proper consistency and well brushed out so as to show a minimum of brush marks.
- b) All coats shall be thoroughly dry before the succeeding coat is applied.
- c) Where surfaces are not fully covered or cannot be satisfactorily finished in the number of coats specified such preparatory coats and subsequent coats as may be required shall be applied to attain the desired evenness of surface without extra cost to the owner.
- d) Where surface is not in proper condition to receive the coat the Engineer shall be notified immediately. Work on the questioned portion(s) shall not start until clearance be proceed is ordered by , the Engineer.
- e) Hardware, lighting fixture and other similar items shall be removed or 'protected during the painting varnishing and related work operations and re-installed after completion of the work.

1032.3.7 Procedure for Sea-Mist Finish

- a) Depress wood grain by steel brush and sand surface lightly.
- b) Apply sanding sealer.
- c) Apply two coats of industrial lacquer paint.
- d) Spray last coat of industrial lacquer paint mixed with sanding sealer.
- e) Apply wood paste filler thinned with turpentine or paint thinner into the wood surface.
- f) Wipe off wood paste filler immediately.
- g) Spray flat or gloss lacquer whichever is specified.

1032.3.8 Procedure for Varnish Finish

- a) Sand surface thoroughly.
- b) Putty all cracks and other wood imperfections with wood paste filler.
- c) Apply oil stain.
- d) Apply lacquer sanding sealer.
- e) Sand surface along the grain.
- f) Spray three (3) coats of clear dead flat lacquer.
- g) Polish surface coated using cloth pad.
- h) Spray gloss lacquer or flat lacquer whichever is desired or specified.

1032.3.9 Procedure for Ducco Finish

- a) Sand surface thoroughly.
- b) Apply primer surface white or gray by brush or spray.
- c) Apply lacquer spot putty in thin coat. Allow each coat for become thoroughly dry before applying next coat.
- d) Apply primer surfaces and then allow drying in two (2) hours before applying the next coat.
- e) Apply a coat of flat tone semi-gloss enamel as per color scheme submitted and approved by the Engineer.

1032.4 Method of Measurement

The areas of concrete, wood and metal surfaces applied with varnish, paint and other related coating materials shall be measured in square meters as desired and accepted to the satisfaction of the Engineer.

1032.5 Basis of Payment

The accepted work shall be paid at the unit bid price, which price and payment constitute full compensation for furnishing all materials, labor, equipment, tools and other incidental necessary to complete this Item.

Payment will made under:

Pay Item Number	Description	Unit of Measurement
1032(a)	PAINTING WORKS	SQ.M.

ITEM 1047 – METAL STRUCTURES

1047.1 Description

This work shall consist of steel structures and the steel structure portions of composite structures, constructed in reasonably close conformity with the lines, grades and dimensions shown on the Plans or established by the Engineer.

The work will include the furnishing, fabricating, hauling, erecting, welding and painting of structural metals called for in the Special Provision or shown on the Plans. Structural metals will include structural steel, rivet, welding, special and alloy steels,

steel forgings and castings and iron castings. This work will also include any incidental metal construction not otherwise provided for, all in accordance with these Specifications, Plans and Special Provisions.

1047.2 Material and Construction Requirements

Materials shall meet the requirements of Item 712, Structural Metal; Item 409, Welded Structural Steel, and Item 409, Welded Structural Steel; and Item 709, Paints.

1047.3 Method of Measurement

Pay Item Number	Description	Unit of Measurement
1047	METAL STRUCTURES	Lump Sum

ITEM 1014(1)b2 - PREPAINTED METAL SHEETS

1014(1)b2.1 Description

This Item shall consist of furnishing all pre-painted metal sheet materials, tools and equipment, plant including labor required in undertaking the proper installation complete as shown on the Plans and in accordance with this Specification.

1014(1)b2.2 Material Requirements

All pre-painted metal sheet and roofing accessories shall be oven baked painted true to profiles indicated on the Plans.

1014(1)b2.2.1 Pre-Painted Roofing Sheets

Pre-painted roofing sheets shall be fabricated from cold rolled galvanized iron sheets specially tempered steel for extra strength and durability. It shall conform to the material requirements defined in PNS 67: 1985. Profile section in identifying the architectural moulded rib to be used are as follows: Regular corrugated, Quad-rib, Tri-wave, Rib-wide, twin-rib, etc. Desired color shall be subject to the approval of the Architect/Engineer.

1014.2.2 Gutters, Valleys, Flashings Hip and Ridge roll shall be fabricated from gauge 24 (.600 mm thick) cold-rolled plain galvanized iron sheets specially tempered steel. Profile section shall be as indicated on the Plans.

1014.2.3 Fastening hardware shall be of galvanized iron straps and rivets. G.I. straps are of .500 mm thick x 16 mm wide x 267 mm long (gauge 26 x 5/8" x 10-1/2") and standard rivets.

1014(1)b2.2.4 Base metal thickness shall correspond to the following gauge designation available locally as follows:

a) Base Metal Thickness	Designated Gauges
.400 mm thick	Gauge 28
.500 mm thick	Gauge 26
.600 mm thick	Gauge 24
.800 mm thick	Gauge 22

b) Protective Coatings

	Thickness
1. Zinc	34.4 microns (244 gm/m ²)
2. Paint coatings	Top coat 15.20 microns Bottom coat 6.8 microns

a) Overall thickness with protective coats

b) .400 mm	.428-451 mm
.500 mm	.532-551 mm
.600 mm	.638-651 mm

c) Length of roofing sheets - available in cut to length long span length up to 18.29 meters

d) Special length and thickness are available by arrangements.

1014(1)b2.3 Construction Requirements

Before any installation work is commenced, the Contractor shall ascertain that the top faces of the purlins are in proper alignment. Correct the alignment as necessary in order to have the top faces of the purlins on an even plane.

1014(1)b2.3.1 Handling/Lifting/Positioning of Sheets

Sheets shall be handled carefully to prevent damage to the paint coating. Lift all sheets or sheet packs on to the roof frame with the overlapping down-turned edge facing towards the side of the roof where installation will commence, otherwise sheets will have to be turned end-to-end during installation.

1014(1)b2.3.2 Installation Procedure

1014(1)b2.3.2.1 Start roofing installation by placing the first sheet in position with the downturned edge in line with other building elements and fastened to supports as recommended.

1014(1)b2.3.2.2 Place the downturned edge of the next sheet over the edge of the first sheet, to provide side lap and hold the side lap firmly in place. Continue the same procedure for subsequent sheets until the whole roofing area is covered and/or (Adopt installation procedure provided in the instruction manual for each type of Architectural molded rib profile section).

1014(1)b2.3.2.3 For walling applications follow the procedure for roofing. Allow a minimum end lap of 100 mm (4") for vertical walling.

1014(1)b2.3.3 Gutters, Valleys, Flashing ridge and Hip rolls

Gutters, valleys, flashing ridge and hip rolls shall be fastened where indicated on the Plans by self-tapping screws or galvanized iron straps and rivets.

1014(1)b2.3.4 End Laps

In case handling or transport consideration requires to use two or more end lapped sheets to provide full length coverage for the roof run, install each line of sheets from bottom to top or from eave line to apex of roof framing. Provide 150 mm minimum end lap.

1014(1)b2.3.5 Anchorage/Fastening

1014(1)b2.3.5.1 Pre-painted steel roofing sheets shall be fastened to the wood purlins with standard length G.I. straps and rivets.

1014(1)b2.3.5.2 For steel frame up to 4.5 mm thick use self-drilling screw No. 12 by 35 mm long hexagonal head with neoprene washer.

1014(1)b2.3.5.3 For steel support up to 5 mm thick or more use thread cutting screw No. 12 by 40 mm long hexagonal head with neoprene washer.

1014(1)b2.3.5.4 Side lap fastener use self-drilling screw NO.1 0 by 16 mm long hexagonal head with neoprene washer.

1014(1)b2.3.5.5 Valley fastened to lumber and for walling use self-drilling wood screw No. 12 by 25 mm long hexagonal head with neoprene washer.

1014(1)b2.3.5.6 Valleys fastened to steel supports use self-drilling screws, hexagonal head with neoprene washer. Drill size is 5 mm diameter.

1014(1)b2.3.6 Cutting of Sheets

1014(1)b2.3.6.1 In cutting pre painted steel roofing sheets and accessories to place the exposed color side down. Cutting shall be carried out on the ground and not over the top of other painted roofing product.

1014(1)b2.3.6.2 Power cutting or drilling to be done or carried out on pre-painted products already installed or laid in position, the area around holes or cuts shall be masked to shield the paint from hot fillings.

1014(1)b2.3.7 Storage and Protection

Pre-painted steel roofing, walling products and accessories should be delivered to the jobsite in strapped bundles. Sheets and/or bundles shall be neatly stacked in the ground and if left in the open it shall be protected by covering the stack materials with loose tarpaulin.

1014(1)b2.4 Method of Measurement

The work done under this Item shall be measured by actual area covered or installed with pre-painted steel roofing and/or walling in square meters and accepted to the satisfaction of the Engineer/Architect.

1014(1)b2.5 Basis of Payment

The area of pre-painted steel roofing and/or walling in square meters as provided in Section 1014(1)b2 shall be paid for at the unit bid or contract unit price which payment shall constitute full compensation including labor, materials, tools and incidents necessary to complete this Item.

Payment shall be made under:

Pay Item Number	Description	Unit of Measurement
1014(1)b2	PRE PAINTED METAL SHEETS	SQ.M.

ITEM 1100 - CONDUITS, BOXES & FITTINGS

1100.1 Description

This Item shall consist of the furnishing and installation of the complete conduit work consisting of electrical conduits; conduit boxes such as junction boxes, pull boxes, utility boxes, octagonal and square boxes; conduit fittings such as couplings, locknuts and bushings and other electrical materials needed to complete the conduit roughing-in work of this project.

1100.2 Material Requirements

All materials shall be brand new and shall be of the approved type meeting all the requirements of the Philippine Electrical Code and bearing the Philippine Standard Agency (PSA) mark.

1100.2.1 Conduits

Conduits shall be standard rigid steel, zinc coated or galvanized. Intermediate metal conduit may be used if shown or specified on the approved Plans. PVC conduit if required shall be Schedule 40. Enamel coated steel conduits and conduits with rough inner surfaces are not acceptable.

1100.2.2 Conduit Boxes

All conduit boxes shall be Code gauge steel and galvanized. Outlet boxes shall be galvanized pressed steel of standard make. In general, outlet boxes shall be at least 100 mm square or octagonal, 53 mm deep and 16 mm minimum gauge.

1100.2.3 Conduit Fittings

All conduit fittings such as locknuts and bushings shall be galvanized of standard make.

1100.3 Construction Requirements

All works throughout shall be executed in the best practice in a workmanlike manner by qualified and experienced electricians under the immediate supervision of a duly licensed Electrical Engineer.

1100.3.1 Conduits

Conduits should be cut square with a hacksaw and reamed. Bends shall be made with the required radius. In making bends only conduit bending apparatus will be used. The use of a pipe tee or vise for bending conduits shall not be permitted. Conduits which have been crushed, deformed or flattened shall not be installed. No running thread shall be allowed. Conduit runs crossing construction joints of the building shall be provided with standard expansion fittings of the approved type.

No conduits shall be used in any system smaller than 12 mm diameter electric trade size nor shall have more than four (4) 90-degree bends in anyone run and where necessary, pull boxes shall be provided.

All ends of conduits which are left empty in cabinets and conduit boxes shall be plugged with lead or approved pipe caps so as to prevent the entrance of white ants and dirt within the conduit system. Pull wires shall be inserted in the empty ducts before they are closed with lead or pipe caps and shall be left therein for future use.

On exposed work, all pipes and outlet boxes shall be secured by means of galvanized metal clamps which shall be held in place by means of machine screws. When running over concrete surfaces, the screws shall be held in place by means of expansion sleeves for big pipes and rolled lead sheet for small pipes. All pipes shall be run at right angles to and parallel with the surrounding walls. No diagonal run shall be allowed and all bends and offsets shall be avoided as much as possible. Conduits shall be supported at 1,500 mm intervals maximum.

1100.3.2 Conduit Boxes & Fittings

Provide conduit boxes for pulling and splicing wires and outlet boxes for installation of wiring devices.

As a rule, provide junction boxes or pull boxes in all runs greater than 30 meters in length, for horizontal runs. For other lengths, provide boxes as required for splices or pulling. Pull boxes shall be installed in inconspicuous but accessible locations.

Support boxes independently of conduits entering by means of bolts, red hangers or other suitable means.

Conduit boxes shall be installed plumb and securely fastened. They shall be set flush with the surface of the structure in which they are installed where conduits are run concealed.

All convenience and wall switch outlet boxes for concealed conduit work shall be deep, rectangular flush type boxes. Four-inch octagonal flush type boxes shall be used for all ceiling light outlets and shall be of the deep type where three or more conduits connect to a single box.

Floor mounted outlet boxes required shall be waterproof type with flush brass floor plate and brass bell nozzle.

All boxes shall be painted with antirust red lead paint after installation.

All conduits shall be fitted with approved standard galvanized bushing and locknuts where they enter cabinets and conduit boxes.

Junction and pull boxes of code gauge steel shall be provided as indicated or as required to facilitate the pulling of wires and cables.

1100.4 Method of Measurement

The work under this Item shall be measured either by lengths, pieces, pairs, lot and set actually placed and installed as shown on the approved Plans.

1100.5 Basis of Payment

All works performed and measured and as provided for in the Bill of Quantities shall be paid for at the Unit Bid or Contract Unit Price which payment shall constitute full compensation including labor, materials, tools and incidentals necessary to complete this Item.

1100.6 General Specifications

The work to be done under this division of specifications consists of the fabrication, furnishing, delivery and installation, complete in all details of the electrical work, at the subject premises and all work material's incidental to the proper completion of the installation, except those portions of the work which are expressly stated to be done by other fields. All works shall be done in accordance with the rules and regulations and with the specifications.

1100.7 Specifications on:

1. Lighting fixtures and lamp

All lighting fixtures and lamps are as specified and listed on lighting fixture schedule.

For fluorescent lamp, it shall be 40-watt rapid start cool-white. All fluorescent ballast shall be 230-volt, high power factor, of good quality materials and approved by the Bureau of Product Standards (BPS).

2. Material Requirements

All materials to be used shall conform to the BPS specification.

3. Construction Requirements

All grounding system installation shall be executed in accordance with the approved plans.

Grounding system shall include building perimeter ground wires, ground rods, clamps, connectors, ground wells and ground wire taps as shown in the approved design.

1100.8 Auxiliary Systems

All auxiliary systems such as telephone and intercom system, time clock system, fire alarm system and public address/nurse's call/paging system installations shall be done in accordance with the approved design.

All materials to be used shall conform to the Bureau of Product Standards (BPS) specifications.

1100.9 Important requirement regarding supervision of the work and submission of certificate of completion.

All wiring installation herein shall be done under the direct supervision of a licensed Electrical Engineer at the expense of the Contractor. The contractor shall submit the certificate of completion duly approved by the owner's representative.

1100.10 Test and guarantee

Upon completion of the electrical construction work, the contractor shall provide all test equipment and personnel and to submit written copies of all test results.

The contractor shall guarantee the electrical installation are done and in accordance with the approved plans and specifications. The contractor shall guarantee that the electrical systems are free from' all grounds and from all defective workmanship and materials and will remain so for a period of one year from date and acceptance of works. Any defect shall be remedied by the Contractor at his own expense.

Payment shall be made under:

Pay Item Number	Description	Unit of Measurement
(1)	RSC CONDUITS PIPE WITH COUPLINGS	LENGTH
(2)	LOCKNUT AND BUSHINGS	PAIRS
(3)	CONDUITS PIPE ADOPTOR	PIECES
(4)	UTILITY BOXES	PIECES
(5)	RUBBER TAPE	ROLLS

ITEM 1101 - WIRES AND WIRING DEVICES

1101.1 Description

This Item shall consist of the furnishing and installation of all wires and wiring devices consisting of electric wires and cables, wall switches, convenience receptacles, heavy duty receptables and other devices shown on the approved Plans but not mentioned in these specifications.

1101.2 Material Requirements

Wires and cables shall be of the approved type meeting all the requirements of the Philippine Electrical Code and bearing the PSA mark. Unless specified or indicated otherwise, all power and lighting conductors shall be insulated for 600 volts.

All wires shall be copper, soft drawn and annealed, smooth and of cylindrical form and shall be centrally located inside the insulation.

All wiring devices shall be standard products of reputable electrical manufacturers. Wall switches shall be rated at least 1 OA, 250 volts and shall be spring operated, flush, tumbler type. Duplex convenience receptacles shall be rated at least 15A, 250 volts, flush, parallel slots.

Single heavy duty receptacles shall be rated at least 20A, 250 volts. 3wire, flush, polarized type.

1101.3 Construction Requirements

Conductors or wires shall not be drawn in conduits until after the cement piaster is dry and the conduits are thoroughly cleaned and free from dirt and moisture. In drawing wires into conduits, sufficient slack shall be allowed to permit easy connections for fixtures, switches, receptacles and other wiring devices without the use of additional splices.

All conductors of convenience outlets and lighting branch circuit home runs shall be wired with a minimum of 3.5 mm in size. Circuit home runs to panel boards shall not be smaller than 3.5 mm but all home runs to panel board more than 30 meters shall not be smaller than 5.5 mm. No conductor shall be less than 2 mm in size.

All wires of 14mm and larger in size shall be connected to panels and apparatus by means of approved type lugs or connectors of the solder less type, sufficiently large enough to enclose all strands of the conductors and securely fastened. They shall not loosen under vibration or normal strain.

All joints, taps and splices on wires larger than 14 mm shall be made of suitable solder less connectors of the approved type and size. They shall be taped with rubber and PVC tapes providing insulation not less than that of the conductors.

No splices or joints shall be permitted in either feeder or branch conductors except within outlet boxes or accessible junction boxes or pull boxes. All joints in branch circuit wiring shall be made mechanically and electrically secured by approved splicing devices and taped with rubber and PVC tapes in a manner which will make their insulation as that of the conductor.

All wall switches and receptacles shall be fitted with standard Bakelite face plate covers. Device plates for flush mounting shall be installed with all four edges in continuous contact with finished wall surfaces without the use of coiled wire or similar devices. Plaster fillings will not be permitted. Plates installed in wet locations shall be gasketed.

When more than one switch or device is indicated in a single location, gang plate shall be used.

1101.4 Method of Measurement

The work under this Item shall be measured either by meters, rolls, pieces, and set, actually placed and installed as shown on the Plans.

1101.5 Basis of Payment

All work performed and measured and as provided for in this Bid of Quantities shall be paid for at the Unit Bid or Contract Unit Price which payment shall constitute full compensation including labor, materials, tools and incidentals necessary to complete this Item.

Payment shall be made under:

Pay Item Number	Description	Unit of Measurement
(1)	ELECTRIC WIRE	METER OF ROLLS
(2)	SINGLE SWITCH	PIECES
(3)	TWO WAY SWITCH	PIECES
(4)	THREE WAY SWITCH	PIECES
(5)	DUPLEX CONVENIENCE RECEPTACLES	SETS

ITEM 1102 - POWER LOAD CENTER, SWITCHGEAR AND PANELBOARDS

1102.1 Description

This Item shall consist of the furnishing and installation of the power load center unit substation or low voltage switchgear and distribution panel boards at the location shown or the approved Plans complete with transformer, circuit breakers, cabinets and all accessories, completely wired and ready for service.

1102.2 Material Requirements

All materials shall be brand new and shall be of the approved type. It shall conform to the requirements of the Philippine Electrical Code and shall bear the Philippine Standard Agency (PSA) mark.

1102.2.1 Power Load Center Unit Substation

The Contractor shall furnish and install an indoor-type Power Load Center Unit Substation at the location shown on the approved Plans if required. It shall be totally metal-enclosed, dead front and shall consist of the following coordinated component parts:

1102.2.2 High Voltage Primary Section:

High voltage primary incoming line section consisting of the following parts and related accessories:

- a) One (1) Air-filled Interrupter Switch, 2-position (open-close) installed in a suitable air-filled metal enclosure and shall have sufficient interrupting capacity to carry the electrical load. It shall be provided with key interlock with the cubicle for the power fuses to prevent access to the fuses unless the switch is open.
- b) Three (3)-power fuses mounted in separate compartments within the switch housing and accessible by a hinged door.
- c) One (1) set of high voltage potheads or 3-conductor cables or three single conductor cables
- d) Lightning arresters shall be installed at the high voltage cubicle if required.

Items (a) and (b) above could be substituted with a power circuit breaker with the correct rating and capacity.

1102.2.3 Transformer Section

The transformer section shall consist of a power transformer with ratings and capacities as shown on the plans. It shall be oil liquid-filled non-flammable type and designed in accordance with the latest applicable standards.

The transformer shall be provided with four (4) approximately 2 1/2 % rated KVA taps on the primary winding in most cases one (1) above and three (3) below rated primary voltage and shall be changed by means of externally gang-operated manual tap changer only when the transformer is de-energized. Tap changing under load is acceptable if transformer has been so designed.

The following accessories shall be provided with the transformer, namely: drain valve, sampling device, filling connection, oil liquid level gauge, ground pad, top filter press connection, lifting lugs, diagrammatic nameplate, relief valve, thermometer and other necessary related accessories. The high-voltage and low-voltage bushings and transition flange shall be properly coordinated for field connection to the incoming line section and low voltage switchboard section, respectively.

1102.2.4 Low-Voltage Switchboard Section

The low-voltage switchboard shall be standard modular-unitized units, metal-built, dead front, and safety type construction and shall consist of the following:

(a) Switchboard Housing

The housing shall be heavy gauge steel sheet, dead front type, gray enamel finish complete with frame supports, steel bracings, steel sheet panel boards, removable rear plates, copper bus bars, and all other necessary accessories to insure sufficient mechanical strength and safety. It shall be provided with grounding bolts and clamps.

(b) Secondary Metering Section

The secondary metering section shall consist of one (1) ammeter, AC, indicating type; one (1) voltmeter, AC, indicating type, one (1) ammeter transfer switch for 3-phase; one (1) voltmeter transfer switch for 3phase; and current transformers of suitable rating and capacity.

The above-mentioned instruments shall be installed in one compartment above the main breaker and shall be complete with all necessary accessories completely wired, ready for use.

(c) Main Circuit Breaker

The main circuit breaker shall be draw-out type, manually or electrically operated as required with ratings and capacity as shown on the approved Plans.

The main breaker shall include insulated control switch if electrically operated, manual trip button, magnetic tripping devices, adjustable time over current protection and instantaneous short circuit trip and all necessary accessories to insure safe and efficient operation.

(d) Feeder Circuit Breakers

There shall be as many feeder breakers as are shown on the single line diagram or schematic riser diagram and schedule of loads and computations on the plans. The circuit breakers shall be draw out or molded case as required. The circuit breakers shall each have sufficient interrupting capacity and shall be manually operated complete with trip devices and all necessary accessories to insure safe and efficient operation. The number, ratings, capacities of the feeder branch circuit breakers shall be as shown on the approved Plans.

Circuit breakers shall each be of the indicating type, providing "ON" - "OFF" and "TRIP" positions of the operating handles and shall each be provided with nameplate for branch circuit designation. The circuit breaker shall be so designed that an overload or short on one pole automatically causes all poles to open.

1102.2.5 Low-Voltage' Switchgear

(For projects requiring 'low-voltage switchgear only).

The Contractor shall furnish and install low-voltage switchgear at the location shown on the plans. It shall be metal-clad, dead front, free standing, safety type construction and shall have copper bus bars of sufficient size, braced to resist allowable root mean square (RMS) symmetrical short circuit stresses, and all necessary accessories.

The low-voltage switchgear shall consist of the switchgear housing, secondary metering, main breaker and feeder branch circuit breakers and all necessary accessories, completely wired, ready for service.

1102.2.6 Grounding System:

All non-current carrying metallic parts like conduits, cabinets and equipment frames shall be properly grounded in accordance with the Philippine Electrical Code, latest edition.

The size of the ground rods and ground wires shall be as shown on the approved Plans. The ground resistance shall not be more than 5 ohms.

Panel boards and Cabinets

Panel boards shall conform to the schedule of panel boards as shown on the approved Plans with respect to supply characteristics, rating of main lugs or main circuit breaker, number and ratings and capacities of branch circuit breakers.

Panel boards shall consist of a factory completed dead front assembly mounted in an enclosing flush type cabinet consisting of code gauge galvanized sheet steel box with trim and door. Each door shall be provided with catch lock and two(2) keys. Panel boards shall be provided with - directories and shall be printed to indicate load served by each circuit.

Panel board cabinets and trims shall be suitable for the type of mounting shown on the approved Plans. The inside and outside of panel board cabinets and trims shall be factory painted with one rust proofing primer coat and two finish shop coats of pearl gray enamel paint.

Main and branch circuit breakers for panel boards shall have the rating, capacity and number of poles as shown on the approved Plans. Breakers shall be thermal magnetic type. Multiple breakers shall be of the common trip type having a single operating handle. For 50-ampere breaker or less, it may consist of single-pole breaker permanently assembled at the factory into a multi-pole unit.

1102.3 Construction Requirements

The Contractor shall install the Power Load Center Unit Substation or Low-Voltage Switchgear and Panel boards at the locations shown on the approved Plans.

Standard panels and cabinets shall be used and assembled on the job. All panels shall be of dead front construction furnished with trims for flush or surface mounting as required.

1102.4 Method of Measurement

The work under this Item shall be measured either by set and pieces actually placed and installed as shown on the approved Plans.

1102.5 Basis of Payment

All works performed and measured and as provided for in the Bill of Quantities shall be paid for at the Unit Bid or Contract Unit Price which payment shall constitute full compensation including labor, materials, tools and incidentals necessary to complete this Item.

Payment shall be made under:

Pay Item Number	Description	Unit of Measurement
1102.(a)	POWER LOAD CENTER, SWITCHGEAR AND PANELBOARDS	LUMP SUM

ITEM 1001 - STORM DRAINAGE AND SEWERAGE SYSTEM

1001.1 Description

This Item shall consist of furnishing all materials, equipment and labor for the complete installation of the storm drainage system to include all piping's, gutters, canals, catch basins, junction boxes, hand holes, manholes and other appurtenant structures, and sewerage system to include all sanitary sewer piping and septic vault where no public sewer exist, from the building to the point of discharge.

1001.2 Material Requirements

1001.2.1 Materials for storm drainage system shall meet the requirements specified in the following standard specifications:

Portland Cement	ASTM C-150
Fine and Coarse Aggregate	ASTM C-33
Reinforcing Steel	ASTM A-615
Non-reinforced Concrete Pipes	ASTM C-14
Reinforced Concrete Pipes	ASTM C-76 (AASHTO M-86)

Cast Iron Pipes (for conductors and downspout)	ASTM A-74
Galvanized Iron Pipes Scheduled 40 (for conductors and downspouts)	ASTM A-120
Polyvinyl Chloride (PVC) (for conductors and downspouts)	ASTM 2729

Where the covers for catch basins, junction boxes, manholes and canals for gratings are required same shall be made of wrought iron and of the dimensions as shown on the Plans.

1001.2.2 Materials for sewerage system shall meet the requirements specified in the following standard specifications:

Cast Iron Pipes and Fittings	ASTM A-74
Pig Lead (for securing and sealing joint)	ASTM B 29-77
PVC Pipes and Fittings (where called in Plans)	ASTM 01784
Solvent Cement (for securing PVC joints)	ASTM 02564

Where PVC pipes and fittings are used, joints shall be secured with rubber "O" ring or solvent cement, as the case maybe. Oakum for joints in bell and spigot pipes shall be made from hemp fiber, braided or twisted and oil impregnated free from lumps, dirt and extraneous matter.

1001.3 Construction Requirements

1001.3.1 Installation of Pipes

Under no circumstances shall pipes shall be laid under water and when the trench condition or the weather is unsuitable for such work.

- a. Bedding. Materials such as sand, sandy soil or any approved material shall be used to provide a firm foundation of uniform density. The bedding shall have a minimum thickness equivalent to one-fourth (1/4) of the pipe's diameter.
- b. Laying of Pipes. Proper facilities shall be provided for lowering and placing pipes into trenches in order to preclude damage. Laying of pipes shall start upgrade with the spigot end of bell-and-spigot pipe, or the tongue end of tongue-and-groove pipe, positioned towards the direction of the flow. The pipes shall be laid in accordance with the grades and alignments shown in the Plans.

The spigots or tongues shall be adjusted in bells or grooves to provide uniform space around joints to receive mortar. Blocking or wedging between spigot and bell or between tongue and groove to attain proper spacing shall be allowed provided such blocking/wedging shall not interfere and shall not affect the water tightness of the joint.

- c. Bell and Spigot Joint for Drain Pipe. The first pipe shall be properly bedded at the required grade. Just below the spigot of the first unit, a sufficient space shall be provided for engaging the bell end of the second pipe.

The spigot shall be carefully cleaned with a wet brush and the upper exterior portion applied with mortar to such a thickness as to bring the inner surfaces of the abutting pipes flush and even. The bell end of the second pipe shall be cleaned with a wet brush and uniformly matched with the spigot of the first pipe so that the sections are closely fitted. After the second pipe is laid, the remainder of the joint shall be fitted with mortar, and a bead shall be formed around the outside of the joints with sufficient amount of additional mortar. The inside of the joints shall be wiped and finished smooth. The mortar bead on the outside shore immediately be protected with a cover of wet burlap or wet earth for at least three (3) days for curing.

- d. Tongue and Groove Joint for Concrete Pipe. The first pipe shall be properly bedded. A shallow excavation shall be made underneath the joint and filled with mortar to provide a bed second pipe. The tongue end of the first pipe shall be carefully cleaned with wet brush and soft mortar applied around the upper half of the tongue. After cleaning and positioning the second pipe close to the first, mortar shall be applied around the lower half of the groove. With just sufficient thrust, the second pipe shall be brought in close contact with the first until mortar is squeezed out of the joint. Sufficient mortar shall be used to fill the joint and to form a bead on the outside.
- e. Mortar for Joint. Mortar shall be a mixture of Portland Cement, sand and water mixed in the proportion by volume of one part cement to two parts of clean sand with just sufficient amount of water for plasticity.
- f. Leaded Joints of Cast Iron Pipes. Joints of cast iron pipes shall be packed with braided or twisted oil-impregnated hemp or oakum, properly caulked around the joint. The packing shall be at least 20mm below the rim of the hub or bell and this space shall be filled with molten pig lead in one continuous pouring. The "ring" of pig lead formed around the joint shall be properly caulked by appropriate caulking tools to render the joints watertight.

1001.3.2 Concrete structures.

Concrete structures such as catch basins, canal gutters, junction boxes and manholes for the drainage system, and septic vault for sewerage system, shall be constructed in accordance with the Plans and Specifications on Concrete Work.

1001.3.2 Sewer Connections and Clean-Outs

- a) The outlet of the septic vault shall be connected to the street drain or to other discharge point where no sanitary sewer exists. Connection with the sanitary sewer shall not be made without the permission of the proper authorities, but shall be made in such a manner that any and all the service water, as well as house and other liquid wastes, will flow to the sanitary sewer. Provided, that isolated faucets used exclusively for garden purposes may, in the discretion of the proper authorities, be allowed not to flow into the sanitary sewer.
- b) Clean-outs or rodding holes consisting of cast iron extensions with long sweep elbow fittings shall be provided at the ends of runs and at every change of directions. Clean-outs shall be capped with cast brass ferrules with threads and screwed-on removable brass plugs. Clean-outs extended outside the building and raised to the level of finished grade shall be terminated with the same cast brass ferrule with brass plug set into a concrete slab shall be 150mm thick and 300mm square, finish flush with grade.

1001.3.2 Incidental Earthwork

Incidental earthwork for the storm drainage and sewerage systems, such as excavation and backfilling shall be undertaken in accordance with applicable part of Excavation Filling and Grading.

1001.3.3 Inspection and Quality Control

Materials shall be inspected and accepted as to quality before same are installed. Piping's installed in trenches shall first be inspected, tested and approved by the Engineer before these are covered or backfilled. All defects/ lakes disclosed by the water test shall be remedied to the satisfaction of the Engineer and any extra cost shall be at the expense of the Contractor.

1001.4 Method of Measurement

Pipes, culverts, gutters, canals and gratings installed in place and accepted by the Engineer, shall be measured by the meter along their axes. Catch basins, junction boxes, manholes and septic vault shall be measured by the number of units constructed and accepted.

1001.5 Basis of Payment

The quantities as determined in sub-section 1001.4 shall be paid at the contract unit price for each of the Items which shall constitute full compensation for all materials, labor, tools and equipment and all other incidentals necessary to complete the Item.

Payment shall be made under:

Pay Item Number	Description	Unit of Measurement
1001.2	STORM DRAINAGE AND SEWER SYSTEM	LUMP SUM

ITEM 1002 – PLUMBING AND PLUMBING FIXTURES

1002.1 Description

This item shall consist of furnishing all materials, tools, equipment and fixtures required as shown on the Plans for the satisfactory performance of the entire plumbing system including installation in accordance with the edition of the National Plumbing Code, and this Specification.

1002.2 Material Requirements

All piping materials, fixtures and appliances fitting accessories whether specifically mentioned or not but necessary to complete this item shall be furnished and installed.

1002.2.1 Cast Iron Soil Pipes and Fittings

Pipes and fitting materials shall comply with the specification requirements defined in PNS/SAO 4-: 1974. The material and standards of manufacture are herein described:

Cast Iron - the casting shall be made of gray iron which shall be sound, free from cracks, sand and blow holes. They shall be uniformly low hardness that permits drilling and cutting by ordinary methods. Pipes and fittings shall be true to pattern and of compact closed grained structure.

Quality of Iron – the iron shall be made by the cupola, air furnace, electric furnace or other processes which shall be checked by regular chemical and physical control test. The result shall be gray iron of good quality.

Manufacture – the pipes shall be made with hub and spigot ends or hub ends only. All hubs for pipes and fitting shall be provided with held lead grooves and all spigot ends shall be made with beads or plain if machine cast centrifugally. Pugs shall be wrought or cast, machined to the dimension required and shall be free from defects.

Freedom from defects – pipes and fittings shall be true, smooth and cylindrical, their inner and outer surfaces being as nearly concentric as practicable. They shall be in all aspects, sound and good casting free from laps, pin holes or other imperfections and shall be neatly dressed and carefully fettled. The ends shall be finished reasonably square to their axes.

Clean-outs shall be made of heavy cast brass ferrule with counter sunk screw cover same diameter as the pipe except that they shall not be larger than 100mm diameter.

Caulking lead shall be of molten type peg lead conforming to specification requirements defined in ASTM B-29.

Oakum shall be twisted or braided hemp or abaca fibers slightly impregnated with oil.

1002.2.2 Water Supply Pipes and Fittings

Pipes shall be galvanized iron pipe schedule 40 conforming to specification requirements defined in ASTM A-120 with threaded connection. Under roads where necessary shall be suitably protected as shown on the Plans.

Fittings shall be malleable iron Type II, galvanized iron conforming to specification requirements defined in ASTM A338.

Valves

Valves for water supply shall be bronze body with threaded ends rated 21.0 kg/cm. square. All valves shall be gate valves unless otherwise specified. Gate valves shall have solid wedge body and disc conforming to specification requirements defined in ASTM B-62. Globe valves shall have plug type discs with ferrule threaded ends and bronze body.

Unions

Unions on ferrous pipe 50mm in diameter and smaller shall be malleable iron.

Water Meter

Water meter where required to be furnished by the Contract shall be of the type tested and approved by MWSS.

1002.2.3 Approved Alternate Pipes and Fittings

Pipes and fittings for sanitary and potable water lines as approved alternate shall be Unplasticized Polyvinyl Chloride Pipes and Fittings (UPVC).

Pipes and fittings shall be made of virgin materials conforming to specification requirements define in ASTM D-2241 and PNS 65: 1986. Fitting shall be molded type and designed for solvent cement joint connection for water lines and rubber O-ring seal joint for sanitary lines.

1002.2.5 Plumbing Fixtures and Fittings

All fittings and trimmings for fixtures shall be chromium-plated and polished brass unless otherwise approved. Exposed traps and supply pipes for fixtures shall be connected to the roughing in, piping system at the wall unless otherwise indicated on the Plans. Built-in fixtures shall be watertight with provision of water supply and drainage outlet, fitting and trap seal. Unless otherwise specified, all plumbing fixtures shall be made of vitreous china complete with fittings.

- a) Water closet shall be vitreous china, free standing toilet combination, round front bottom outlet siphonic washdown bowl with extended rear self and closed coupled tank with cover complete with fittings and mounting accessories. Model make and color shall be submitted for approval prior to delivery at jobsite by the Engineer.
- b) Lavatory shall be vitreous china, wall-hung with rear overflow and cast-in soap dishes, pocket hanger with integral china brackets, complete with twin faucets, supply pipes, P-trap and mounting accessories. Where indicated on the Plans to be counter top model make and color shall be approved by the Engineer.
- c) Urinal shall be china vitreous, wall-hung wash-out urinal with extended shields and integral flush spreader, concealed wall-hanger pockets, 19mm top spud complete with fitting and mounting accessories. Model make and color shall be approved by the Engineer.

1002.2.6 Bathroom and Toilet Accessories

- a) Shower head and fitting shall be movable, cone type with escutcheon arm complete with stainless steel shower valve and control lever, all exposed surface to be chromium finish.
- b) Grab bars shall be made of tubular stainless steel pipe provided with safety grip and mounting flange.
- c) Floor drains shall be made of stainless steel beehive type, measuring 100mm x 100mm, and provided with detachable stainless strainer, expanded metal lath type.
- d) Toilet paper holder shall be vitreous china wall mounted. Color shall reconcile with the adjacent fixture and facing tiles.
- e) Soap holder shall be vitreous china wall mounted. Color shall reconcile with the adjacent tile works.
- f) Faucet(s) shall be made of stainless steel for interior use.
- g) Hose-bib(s) shall be made of bronze cast finish.

1002.2.7 Special Plumbing Fixtures

- a) Kitchen sink shall be made of stainless steel self-rimming, single compartment complete with supply fittings, strainer traps, dual control lever and other accessories.
- b) Laboratory sink shall be made of cast iron metal with white porcelain finish with single compartment, flat rim ledge, 762mm x 533mm complete with supply fittings, strainer, trap and other accessories.
- c) Scrub-up sink shall be made of cast iron metal with white porcelain finish measuring 610mm x 610mm complete with supply fittings, strainer, trap and wall mounting accessories.
- d) X-ray developing tank shall be made of cast iron white porcelain finish with three (3) compartment x-ray processing tank, drain plug, open standing drain, 19mm IPS inlet spud complete with stand and mounting accessories
- e) Squat bowl(s) shall be vitreous china, wash down squat bowl with integral foot treads, pail flush type. Color, make and type to be approved by the Engineer.
- f) Grease traps shall be made of cast bronze with detachable cover and mounting accessories.

1002.2.8 Roof Drains, Downspout, Overflow Pipes and Steel Grating

The Contractor shall provide, fit and/or install necessary drains with strainers, where shown on the Plans. Each drain with strainer shall fit the size of the corresponding downspout (or roof leader) over which it is to be installed and in conformity with the following schedule:

- a) Scupper drains (for balconies, parapet) shall be made of bronze base with flashing. Flange threaded outlet and convex with integral flashing clamp bolted to flange.
- b) "Josam" type drains shall be made of bronze base semi-dome with large free area, flashing clamp and integral gravel stopper. To be used at roof decks, canopies, gutters, and elsewhere indicated on the Plans.

- c) Downspouts when encased in concrete, unless otherwise shown on the Plans shall be polyvinyl chloride (PVC). Whether indicated or specified to be cast iron or galvanized iron the same shall meet the specification requirement as herein described.
- d) Overflow pipes shall be made of galvanized iron pipe measuring at least 13mm diameter and spaced 200mm on center.
- e) Steel grating shall be made of wrought iron metals of design on shop drawings approved and surfaces to be coated with shop finish.

1002.2.9 Fire Protection System

- a. Fire hose cabinets shall be locally available consisting of 38mm diameter valve hose rack with nipple 30mm rubber lined hose cable with standing 4268 kg/cm square, nozzle 38mm diameter brass, chromium plated.
- b. Fire standpipe system shall consist of risers and hose valves. Pipe shall be extra strong black iron. Valves to be high grade cast bronze mounted withstanding 79.40 kg. working pressure as indicated on the Plans.
- c. Fire extinguisher shall be portable, suitable for Class A, B, C fires, mounted inside cabinet. Cabinet shall be full flush mounting door with aluminum trim for glass plate, frame and box shall be made of gauge 14 galvanized iron sheet with white interior and red exterior baked enamel finish over primer. Cabinet to be wall mounted and size to be able to accommodate the defined components.
- d. Yard hydrant where shown on the Plans shall match the Integrated Fire Department requirements. Outlet shall be single 63mm diameter gate valves with chain connected caps.

1002.2.10 Built-in appliances such as urinal trough, lavatory and slope sink shall be made as indicated on the Plans, exposed surfaces to be tile wainscoating Complete with fitting accessories required as practiced in this specialty trade.

1002.3 Construction Requirements

The Contractor before any installation work is started shall carefully examine the Plans and shall investigate actual structural and finishing work condition affecting all his work. Where actual condition necessitates a rearrangement of the approved pipe layout, the Contractor shall prepare Plan(s) of the proposed pipe layout for approval by the Engineer.

1002.3.1 Installation of Soil, Waste, Drain and Vent Pipe

- a) All cast iron soil and drainage pipes shall be pitch 6 mm per 300 mm but in no case flatter than 3mm per 300mm.
- b) Horizontal lines shall be supported by well secured length heavy strap hangers. Vertical lines shall be secured strongly by hooks to the building frame and a suitable brackets or chairs shall be provided at the floor from which they start.
- c) All main vertical soil and waste stacks shall be extended full size to and above the roof line to act as vents, except otherwise indicated on the Plans.
- d) Vent pipes on roof spaces shall be run as close as possible to underside of roof with horizontal piping pitched down to stacks without forming traps. Vertical vent pipes may be connected into one main vent riser above the highest vented fixtures.
- e) Where an end or circuit vent pipe from any fixtures is connected to a vent line serving other fixtures, the connections shall be at least 1.20 m above the floor on which the fixtures are located.
- f) Horizontal waist line receiving the discharge from two or more fixtures shall be provided with end vents unless separate venting of fixtures is noted on the Plans.
- g) All changes on pipe sizes on soil and waste lines shall be made with reducing fittings or recessed reducers. All changes in directions shall be made by appropriate use of 45 degrees wyes, half wyes, long sweep quarter bends or elbows may be used in soil and waste lines where the change in the direction of flow is from the horizontal to the vertical and on the discharge from waste closets. Where it becomes necessary to use short radius fittings in other locations the approval of the Engineer shall be obtained prior to installation of the same.
- h) All joints of cast iron pipes in bell and spigot shall be firmly packed with oakum or hemp or caulked with pig at least 25 mm deep.
- i) Cleanouts at the bottom of each soil stack, waste stack, interior down spout and where else indicated shall be the same size as the pipe up to and including 102 mm, 152 mm, for larger pipes.

Cleanouts on floors shall be cast iron ferulle caulked into cast hub and fitted with cast brass screw plug flush with floor. Cleanouts for threaded pipes shall be installed at the foot of soil, waste and drain stacks and on each building drain outside the building.

- j) Vent pipe shall be flashed and made water tight at the roof with ferrule lead sheet. Flushing shall be turned down into pipes.
- k) Each fixtures and place of equipment requiring connection to the drainage system except fixtures with continuous waste shall be equipped with a trap. Each trap shall be placed as near to the fixture as possible. Traps installed on threaded pipe shall be recessed drainage pattern.
- l) Overhead horizontal runs of pipes shall be hung with adjustable wrought iron pipe hanger spaced not over 3.04 m apart except hub and spigot soil pipe which shall have hanger spaced not over 1.50 m apart and located near a hub.

1002.3.7 Inspection, Warranty Test and Disinfection

All pipes, fittings, traps, fixtures, appurtenances and equipment of the plumbing and drainage system shall be inspected and approved by the Engineer to insure compliance with all requirements of all Codes and Regulations referred to in this Specification.

1002.3.7.1 Drainage System Test

1002.3.7.2

- a) The entire drainage and venting system shall have all necessary openings which can be plugged to permit the entire system to be filled with water to the level of the highest stack vent above the roof.
- b) The system shall hold this water for a full 30 minutes during which time there shall be no drop greater than 102 mm.

- c) Where only a portion of the system is to be tested, the test shall be conducted in the same manner as described for the entire system except that a vertical stack 3.00 m highest horizontal line to be tested may be installed and filled with water to maintain sufficient pressure or water pump may be used to supply the required pressure.
- d) If and when the Engineer decides that an additional test is needed, such as an air to smoke test on the drainage system, the Contractor shall perform such test without any additional cost.

1002.3.7.3 Water Test on System

- a) Upon completion of roughing-in and before connecting fixtures the entire cold-water piping system shall be tested at a hydrostatic pressure 1 ½ times the expected working pressure in the system during the operation and remained tight and leak-proofed.
- b) Where piping system is to be concealed the piping system shall be separately in manner similar to that described for the entire system and in the presence of the Engineer or his duly designated representative.

1002.3.7.4 Defective Work

- a) All defected materials replaced and tested will be repeated until satisfactory performance is attained.
- b) Any material replaced for the satisfactory performance of the system made shall be at the expense of the Contractor.
- c) Caulking of screwed joints or holes will not be permitted.

1002.3.7.5 Disinfection

- a) The entire water distribution system shall be thoroughly flushed and treated with chlorine before it is operated for public use.
- b) Disinfection materials shall be liquid chlorine or hypochlorite and shall be introduced in a manner approved as practiced or approved by the Engineer into the water distribution system.
- c) After a contact period of not less than sixteen hours, the heavenly chlorinated water shall be flushed from the system with potable water.
- d) Valves for the water distribution system shall be opened and closed several times during the 16 hours chlorination treatment is done.

1002.3.8 As-Built Drawings

Upon completion of the work, the Contractor shall submit two sets of prints with all as-built changes shown on the drawings in a neat workmanship manner. Such prints shall show changes or actual installation and conditions of the plumbing system in comparison with the original drawings.

1002.4 Method of Measurement

The work done under this item shall be quantified per length and/or number of units as provided in the Bill of Quantities, tested and accepted to the satisfaction of the Engineer.

1002.5 Basis of Payment

The quantified items, installed in place shall be the basis for payment, based from the unit bid price for which prices and payments shall constitute full compensation including labor, materials and incidentals necessary to complete this item.

Payment shall be made:

Pay Item Number	Description	Unit of Measurement
1002(a)	GALVANIZED IRON PIPES AND FITTINGS	PIECES/ LENGHT
1002(b)	PLUMBING FIXTURES	SETS
1002(c)	ROOF DRAIN WITH STRAINER	SETS

Section VII. Drawings



Please see attached plans and designs

Section VIII. Bill of Quantities

Notes on the Bill of Quantities

Objectives

The objectives of the Bill of Quantities are:

- a. to provide sufficient information on the quantities of Works to be performed to enable Bids to be prepared efficiently and accurately; and
- b. when a Contract has been entered into, to provide a priced Bill of Quantities for use in the periodic valuation of Works executed.

In order to attain these objectives, Works should be itemized in the Bill of Quantities in sufficient detail to distinguish between the different classes of Works, or between Works of the same nature carried out in different locations or in other circumstances which may give rise to different considerations of cost. Consistent with these requirements, the layout and content of the Bill of Quantities should be as simple and brief as possible.

Daywork Schedule

A Daywork Schedule should be included only if the probability of unforeseen work, outside the items included in the Bill of Quantities, is high. To facilitate checking by the Entity of the realism of rates quoted by the Bidders, the Daywork Schedule should normally comprise the following:

- a. A list of the various classes of labor, materials, and Constructional Plant for which basic daywork rates or prices are to be inserted by the Bidder, together with a statement of the conditions under which the Contractor will be paid for work executed on a daywork basis.
- b. Nominal quantities for each item of Daywork, to be priced by each Bidder at Daywork rates as Bid. The rate to be entered by the Bidder against each basic Daywork item should include the Contractor's profit, overheads, supervision, and other charges.

Provisional Sums

A general provision for physical contingencies (quantity overruns) may be made by including a provisional sum in the Summary Bill of Quantities. Similarly, a contingency allowance for possible price increases should be provided as a provisional sum in the Summary Bill of Quantities. The inclusion of such provisional sums often facilitates budgetary approval by avoiding the need to request periodic supplementary approvals as the future need arises. Where such provisional sums or contingency allowances are used,

the SCC should state the manner in which they will be used, and under whose authority (usually the Procuring Entity's Representative's).

The estimated cost of specialized work to be carried out, or of special goods to be supplied, by other contractors should be indicated in the relevant part of the Bill of Quantities as a particular provisional sum with an appropriate brief description. A separate procurement procedure is normally carried out by the Procuring Entity to select such specialized contractors. To provide an element of competition among the Bidders in respect of any facilities, amenities, attendance, etc., to be provided by the successful Bidder as prime Contractor for the use and convenience of the specialist contractors, each related provisional sum should be followed by an item in the Bill of Quantities inviting the Bidder to quote a sum for such amenities, facilities, attendance, etc.

Signature Box

A signature box shall be added at the bottom of each page of the Bill of Quantities where the authorized representative of the Bidder shall affix his signature. Failure of the authorized representative to sign each and every page of the Bill of Quantities shall be a cause for rejection of his bid.

These Notes for Preparing a Bill of Quantities are intended only as information for the Procuring Entity or the person drafting the Bidding Documents. They should not be included in the final documents.

Please see attached Bill of Quantities and Detailed Estimates

Section IX. Checklist of Technical and Financial Documents

Notes on the Checklist of Technical and Financial Documents

The prescribed documents in the checklist are mandatory to be submitted in the Bid, but shall be subject to the following:

- a. GPPB Resolution No. 09-2020 on the efficient procurement measures during a State of Calamity or other similar issuances that shall allow the use of alternate documents in lieu of the mandated requirements; or
- b. *The mandatory provisions of Required Forms shall be considered as per GPPB Circular No. 4-2020; or*
- c. any subsequent GPPB issuances adjusting the documentary requirements after the effectivity of the adoption of the PBDs.

The BAC shall be checking the submitted documents of each Bidder against this checklist to ascertain if they are all present, using a non-discretionary “pass/fail” criterion pursuant to Section 30 of the 2016 revised IRR of RA No. 9184.

Checklist of Technical and Financial Documents

I. TECHNICAL COMPONENT ENVELOPE

Class "A" Documents

Legal Documents

- (a) Valid PhilGEPS Registration Certificate (Platinum Membership) (all pages) in accordance with Section 8.5.2 of the IRR;

Technical Documents

- (b) Statement of the prospective bidder of all its ongoing government and private contracts, including contracts awarded but not yet started, if any, whether similar or not similar in nature and complexity to the contract to be bid, (*Sample Form is in Section 10*); **and**
- (c) Statement of the bidder's Single Largest Completed Contract (SLCC) similar to the contract to be bid, except under conditions provided under the rules. SLCC shall be supported by an Owner's Certificate of Final Acceptance issued by the project Owner other than the contractor or the Constructors Performance Evaluation System (CPES) Final Rating, which must be at least satisfactory. In case contracts with the private sector, an equivalent document shall be substituted (*Sample form is in Section 10*); **and**
- (d) Valid PCAB License, or
- (e) Special PCAB License in case of Joint Ventures **and** registration for the type and cost of the contract to be bid; **and**
- (f) Original copy of Bid Security. If in the form of a Surety Bond, submit also a certification issued by the Insurance Commission **or** original copy of Notarized Bid Securing Declaration; **and**
- (g) Project Requirements, which shall include the following:
- a. Organizational chart for the contract to be bid;
- b. List of contractor's key personnel, to be assigned to the contract to be bid, with their complete qualification and experience data;

Key Personnel	No. of Personnel	General Experience	Relevant Experience
Site Engineer/ Site Architect	1	At least 3 years	At least 3 years
Safety Officer – Part time, with COSH training from accredited provider by DOLE	1	At least 3 years	At least 3 years
Electrical Engineer/ Registered Master Electrician	1	At least 3 years	At least 3 years
Sanitary Engineer/ Registered Master Plumber	1	At least 3 years	At least 3 years
Construction Foreman	1	At least 3 years	At least 3 years

- c. List of contractor's major equipment units, which are owned, leased, and/or under purchase agreements, supported by proof of ownership or certification of availability of equipment from the equipment lessor/vendor for the duration of the project, as the case may be; **and**
- d. Certificate of Site Inspection - to be signed by any authorized representative from the Project Management Unit (PMU); and
- (h) Original duly signed Omnibus Sworn Statement (OSS) **and** if applicable, Original Notarized Secretary's Certificate in case of a corporation, partnership, or cooperative; or Original Special Power of Attorney of all members of the joint venture giving full power and authority to its officer to sign the OSS and do acts to represent the Bidder.

Financial Documents

- (i) The prospective bidder's computation of Net Financial Contracting Capacity (NFCC). In the Form, kindly indicate ABC to be bid.

Class "B" Documents

- (j) If applicable, duly signed joint venture agreement (JVA) in accordance with RA No. 4566 and its IRR in case the joint venture is already in existence **or** duly notarized statements from all the potential joint venture partners stating that they will enter into and abide by the provisions of the JVA in the instance that the bid is successful.

II. FINANCIAL COMPONENT ENVELOPE

- (k) Original of duly signed and accomplished Financial Bid Form; **and**

Other documentary requirements under RA No. 9184

- (l) Original of duly signed Bid Prices in the Bill of Quantities; **and**
- (m) Duly accomplished Detailed Estimates Form, including a summary sheet indicating the unit prices of construction materials, labor rates, and equipment rentals used in coming up with the Bid; **and**
- (n) Cash Flow by Quarter; and
- (o) Soft Copy (in CD or USB) of financial proposal to be included in the "original copy" of the bid in Envelope B.

Notes:

The prescribed documents in the checklist are mandatory to be submitted in the Bid, but shall be subject to the following:

- a. This checklist is only a guide to the prospective bidder/s. Each prospective bidder shall take responsibility to ensure the completeness of its submission after taking the steps to carefully examine all of the Bidding Documents and its amendments.*

- b. All photocopied documents shall be marked “certified true copy of the original document” with corresponding signature over printed name of the bidder or its duly authorized representative and indicating the position in the company.*
- c. Bidder shall follow the sequence of items in the checklist of documents for submission and use tabs to facilitate the inspection process.*
- d. Incomplete required documents and expired licenses/ permit shall be a ground for disqualification*
- e. The documents that will be submitted by the bidder shall be used for procurement purposes only.*

Section X. Bidding Forms

1. Bid Form
2. Bid Securing Declaration Form
3. Net Financial Contracting Capacity (NFCC) Form
4. Statement of Single Largest Completed Contract (SLCC) Form
5. Statement of All Ongoing Government & Private Contracts Form
6. Omnibus Sworn Statement (Revised)

Bid Form for the Procurement of Infrastructure Projects
[shall be submitted with the Bid]

BID FORM

Date: _____

Project Identification No.: _____

To: [name and address of Procuring Entity]

Having examined the Philippine Bidding Documents (PBDs) including the Supplemental or Bid Bulletin Numbers [insert numbers], the receipt of which is hereby duly acknowledged, we, the undersigned, declare that:

We have no reservation to the PBDs, including the Supplemental or Bid Bulletins, for the Procurement Project: [insert name of contract];

We offer to execute the Works for this Contract in accordance with the PBDs;

The total price of our Bid in words and figures, excluding any discounts offered below is: [insert information];

The discounts offered and the methodology for their application are: [insert information];

The total bid price includes the cost of all taxes, such as, but not limited to: [specify the applicable taxes, e.g. (i) value added tax (VAT), (ii) income tax, (iii) local taxes, and (iv) other fiscal levies and duties], which are itemized herein and reflected in the detailed estimates,

Our Bid shall be valid within a period stated in the PBDs, and it shall remain binding upon us at any time before the expiration of that period;

If our Bid is accepted, we commit to obtain a Performance Security in the amount of [insert percentage amount] percent of the Contract Price for the due performance of the Contract, or a Performance Securing Declaration in lieu of the allowable forms of Performance Security, subject to the terms and conditions of issued GPPB guidelines² for this purpose;

We are not participating, as Bidders, in more than one Bid in this bidding process, other than alternative offers in accordance with the Bidding Documents;

We understand that this Bid, together with your written acceptance thereof included in your notification of award, shall constitute a binding contract between us, until a formal Contract is prepared and executed; and

We understand that you are not bound to accept the Lowest Calculated Bid or any other Bid that you may receive.

We likewise certify/confirm that the undersigned, is the duly authorized representative of the bidder, and granted full power and authority to do, execute and perform any and all acts necessary to participate, submit the bid, and to sign and execute the ensuing contract for the [Name of Project] of the [Name of the Procuring Entity].

We acknowledge that failure to sign each and every page of this Bid Form, including the Bill of Quantities, shall be a ground for the rejection of our bid.

Name: _____

Legal Capacity: _____

Signature: _____

Duly authorized to sign the Bid for and behalf of: _____

Date: _____

² currently based on GPPB Resolution No. 09-2020

Bid Securing Declaration Form

[shall be submitted with the Bid if bidder opts to provide this form of bid security]

REPUBLIC OF THE PHILIPPINES)
CITY OF _____) S.S.

BID SECURING DECLARATION

Project Identification No.: *[Insert number]*

To: *[Insert name and address of the Procuring Entity]*

I/We, the undersigned, declare that:

1. I/We understand that, according to your conditions, bids must be supported by a Bid Security, which may be in the form of a Bid Securing Declaration.
2. I/We accept that: (a) I/we will be automatically disqualified from bidding for any procurement contract with any procuring entity for a period of two (2) years upon receipt of your Blacklisting Order; and, (b) I/we will pay the applicable fine provided under Section 6 of the Guidelines on the Use of Bid Securing Declaration, within fifteen (15) days from receipt of the written demand by the procuring entity for the commission of acts resulting to the enforcement of the bid securing declaration under Sections 23.1(b), 34.2, 40.1 and 69.1, except 69.1(f), of the IRR of RA No. 9184; without prejudice to other legal action the government may undertake.
3. I/We shall enter into contract with the PE and furnish the required performance security within ten (10) calendar days, from receipt of the Notice of Award.
4. I/We understand that this Bid Securing Declaration shall cease to be valid on the following circumstances:
 - a. Upon expiration of the bid validity period, or any extension thereof pursuant to your request;
 - b. I am/we are declared ineligible or post-disqualified upon receipt of your notice to such effect, and (i) I/we failed to timely file a request for reconsideration or (ii) I/we filed a waiver to avail of said right; and
 - c. I am/we are declared the bidder with the Lowest Calculated Responsive Bid, and I/we have furnished the performance security and signed the Contract.

IN WITNESS WHEREOF, I/We have hereunto set my/our hand/s this ____ day of [month] [year] at [place of execution].

[Insert NAME OF BIDDER OR ITS
AUTHORIZED REPRESENTATIVE] *[Insert signatory's
legal capacity] Affiant*

[Jurat]

[Format shall be based on the latest Rules on Notarial Practice]

Project Identification No. _____
Project Title: _____
ABC of the Project/Lot/Item to be Bid: _____

CERTIFICATE OF NET FINANCIAL CONTRACTING CAPACITY (NFCC)
(Please show computation)

This is to certify that our Net Financial Contracting Capacity (NFCC) in Philippine Pesos _____ (₱ _____) is at least equal to the total ceiling price of the goods/services/works we are bidding. The amount is computed as follows:

$$\text{NFCC} = (\text{CA} - \text{CL}) (15) - \text{C}$$

Where:

CA = Current Assets

CL = Current Liabilities

C = value of all outstanding or uncompleted portions of contracts/projects under ongoing contracts, including awarded contracts yet to be started coinciding with the contract of the bid.

Issued this _____ day of _____, 20____.

(Company Authorized Representative)

NAME:

DESIGNATION:

Note: Kindly attach supporting documents

Procuring Entity: Benguet State University

Name of Project:

Location of the Project:

Statement of Single Largest Completed Contract (SLCC) which is Similar in Nature

Business Name: _____

Business Address: _____

Name of Contract	Date of Contract	a. Owner's Name b. Address c. Telephone Nos. d. Contact Person e. Email Address	a. Date Awarded b. Contract Effectivity	Contract Amount	Contract Duration	a. Date of Completion b. Amount of Completed contract	Date of Final Acceptance	Description/s of the similar project/s
<u>GOVERNMENT</u>								
<u>PRIVATE</u>								

Note: Kindly attach documents to support the above statements (Notice of Award, Notice to Proceed, Contract, Certificate of Completion, Certificate of Final Acceptance, CPES)

Submitted by : _____

Print Name and Signature

Designation : _____

Date : _____

Procuring Entity: *Benguet State University*

Name of Project:

Location of the Project:

Statement of All Ongoing Government & Private Contracts Including Contracts Awarded but Not Yet Started

Business Name:

Business Address:

Name of Contract/Location (A)	Date of Contract (B)	Project Duration (C)	a. Owner's Name b. Address c. Telephone Nos. d. Contact Person e. Email Address (D)	Nature of Work (E)	a. Date of Award b. Date Started c. Date of Completion (F)	Contract Amount (G)	% of Accomplishment		Value of Outstanding Contract (J) (G-I)
							Planned (H)	Actual (I)	
<u>GOVERNMENT</u>									
<u>PRIVATE</u>									

Note: Kindly attach documents to support the above statements (Notice of Award, Contract, Notice to Proceed and other documents). All spaces should be filled out with correct information.

Submitted by : _____
Print Name and Signature

Designation : _____

Date : _____

Omnibus Sworn Statement

REPUBLIC OF THE PHILIPPINES)
CITY/MUNICIPALITY OF _____) S.S.

AFFIDAVIT

I, [Name of Affiant], of legal age, [Civil Status], [Nationality], and residing at [Address of Affiant], after having been duly sworn in accordance with law, do hereby depose and state that:

1. **Select one, delete the other:**

If a sole proprietorship: I am the sole proprietor or authorized representative of [Name of Bidder] with office address at [address of Bidder];

If a partnership, corporation, cooperative, or joint venture: I am the duly authorized and designated representative of [Name of Bidder] with office address at [address of Bidder];

2. **Select one, delete the other:**

[If a sole proprietorship:] As the owner and sole proprietor, or authorized representative of [Name of Bidder], I have full power and authority to do, execute and perform any and all acts necessary to participate, submit the bid, and to sign and execute the ensuing contract for [Name of the Project] of the [Name of the Procuring Entity], as shown in the attached duly notarized Special Power of Attorney;

[If a partnership, corporation, cooperative, or joint venture:] I am granted full power and authority to do, execute and perform any and all acts necessary to participate, submit the bid, and to sign and execute the ensuing contract for [Name of the Project] of the [Name of the Procuring Entity], as shown in the attached [state title of attached document showing proof of authorization (e.g., duly notarized Secretary's Certificate, Board/Partnership Resolution, or Special Power of Attorney, whichever is applicable)];

3. [Name of Bidder] is not "blacklisted" or barred from bidding by the Government of the Philippines or any of its agencies, offices, corporations, or Local Government Units, foreign government/foreign or international financing institution whose blacklisting rules have been recognized by the Government Procurement Policy Board, **by itself or by relation, membership, association, affiliation, or controlling interest with another blacklisted person or entity as defined and provided for in the Uniform Guidelines on Blacklisting;**

4. Each of the documents submitted in satisfaction of the bidding requirements is an authentic copy of the original, complete, and all statements and information provided therein are true and correct;
5. *[Name of Bidder]* is authorizing the Head of the Procuring Entity or its duly authorized representative(s) to verify all the documents submitted;
6. **Select one, delete the rest:**
 - If a sole proprietorship:* The owner or sole proprietor is not related to the Head of the Procuring Entity, members of the Bids and Awards Committee (BAC), the Technical Working Group, and the BAC Secretariat, the head of the Project Management Office or the end-user unit, and the project consultants by consanguinity or affinity up to the third civil degree;
 - If a partnership or cooperative:* None of the officers and members of *[Name of Bidder]* is related to the Head of the Procuring Entity, members of the Bids and Awards Committee (BAC), the Technical Working Group, and the BAC Secretariat, the head of the Project Management Office or the end-user unit, and the project consultants by consanguinity or affinity up to the third civil degree;
 - If a corporation or joint venture:* None of the officers, directors, and controlling stockholders of *[Name of Bidder]* is related to the Head of the Procuring Entity, members of the Bids and Awards Committee (BAC), the Technical Working Group, and the BAC Secretariat, the head of the Project Management Office or the end-user unit, and the project consultants by consanguinity or affinity up to the third civil degree;
7. *[Name of Bidder]* complies with existing labor laws and standards; and
8. *[Name of Bidder]* is aware of and has undertaken the responsibilities as a Bidder in compliance with the Philippine Bidding Documents, which includes:
 - a) Carefully examining all of the Bidding Documents;
 - b) Acknowledging all conditions, local or otherwise, affecting the implementation of the Contract;
 - c) Making an estimate of the facilities available and needed for the contract to be bid, if any; and
 - d) Inquiring or securing Supplemental/Bid Bulletin(s) issued for the *[Name of the Project]*.
9. *[Name of Bidder]* did not give or pay directly or indirectly, any commission, amount, fee, or any form of consideration, pecuniary or otherwise, to any person or official, personnel or representative of the government in relation to any procurement project or activity.
10. **In case advance payment was made or given, failure to perform or deliver any of the obligations and undertakings in the contract shall be sufficient grounds to constitute**

criminal liability for Swindling (Estafa) or the commission of fraud with unfaithfulness or abuse of confidence through misappropriating or converting any payment received by a person or entity under an obligation involving the duty to deliver certain goods or services, to the prejudice of the public and the government of the Philippines pursuant to Article 315 of Act No. 3815 s. 1930, as amended, or the Revised Penal Code.

IN WITNESS WHEREOF, I have hereunto set my hand this ___ day of ___, 20__ at _____, Philippines.

[Insert NAME OF BIDDER OR ITS AUTHORIZED REPRESENTATIVE]

[Insert signatory's legal capacity] Affiant

[Jurat]

[Format shall be based on the latest Rules on Notarial Practice]





BILL OF QUANTITIES

PROJECT TITLE:	REPAIR OF THE POULTRY OFFICE BUILDING		
LOCATION :	BSU LA TRINIDAD CAMPUS, BALILI, LA TRINIDAD, BENGUET		
ABC :	Php.	2,200,000.00	
PROJECT DURATION:	85 C.D.	INCLUSIVE OF:	8 UNWORKABLE DAYS
IMPLEMENTATION MODE:	BY CONTRACT		

PROJECT DESCRIPTION	EQUIPMENT NEEDED		TECHNICAL PERSONEL	
	NO.	DESCRIPTION	NO.	DESCRIPTION
THE PROPOSED PROJECT IS A RENOVATION OF ONE STOREY OFFICE BUILDING. THE SCOPE OF WORK INCLUDES EARTHWORKS, STRUCTURAL WORKS, PLUMBING WORKS, ELECTRICAL WORKS AND FINISHING WORKS.	1	Welding Machine	1	Site Engineer / Site Architect
	1	Jackhammer	1	Part Time Safety Officer
	1	Concrete Saw	1	Sanitary Engineer / RMP
	1	One Bagger Mixer	1	Registered Electrical Engineer/ RME
	1	Bar Bender	1	Construction Foreman
	1	Bar Cutter		
	1	Dump Truck (10 y.d Cap.)		
	1	Plate Compactor		

ITEM NO.	DESCRIPTION	% WEIGHT	QUANTITY	UNIT	UNIT COST	TOTAL COST
I.	OTHER GENERAL REQUIREMENTS					
B.5	PERMITS AND CLEARANCES (BUILDING PERMITS)		1.00	LUMP SUM		
B.5	PROJECT BILLBOARD / SIGNBOARD		1.00	EACH		
B.7	OCCUPATIONAL SAFETY AND HEALTH PROGRAM		1.00	LUMP SUM		
B.9	MOBILIZATION / DEMOBILIZATION		1.00	LUMP SUM		
A.	EARTHWORK					
801(17)	REMOVAL OF OBSTRUCTIONS		1.00	LUMP SUM		
803(1)a	STRUCTURE EXCAVATION (COMMON SOIL)		1.70	CU.M.		
804(1)a	EMBANKMENT FROM THE EXCAVATION		1.70	CU.M.		
804(1)b	EMBANKMENT FROM COMMON BORROW BY EQUIPMENT		33.60	CU.M.		
804(4)	GRAVEL BEDDING		8.02	CU.M.		
B.	PLAIN AND REINFORCED CONCRETE WORK					
900	STRUCTURAL CONCRETE (3500 PSI @28 DAYS)		31.00	CU.M.		
902(1)	REINFORCING STEEL OF REINFORCED CONCRETE		6,534.06	KGS.		
903(2)	FORMS AND FALSEWORKS		227.39	SQ.M.		
C.	FINISHING AND OTHER CIVIL WORKS					
1046(2)a1	CHB NON LOAD BEARING, 100MM - 150MM (INCLUDING REINFORCING STEEL		172.63	SQ.M.		
1021	FLOOR TOPPINGS		66.00	SQ.M.		
1027(1)	CEMENT PLASTER FINISH		349.84	SQ.M.		
1018(1)	GLAZED TILES AND TRIMS		25.34	SQ.M.		
1018(2)	UNGLAZED TILES		40.72	SQ.M.		
1003(2)d1	DRYWALL(METAL FRAME AND FIBER CEMENT BOARD)		43.58	SQ.M.		
1032	PAINTING WORKS (MASONRY/CONCRETE, STEEL)		426.83	SQ.M.		
1007	ALUMINUM FRAMED GLASS DOOR		13.65	SQ.M.		
1008	ALUMINUM GLASS WINDOWS		12.92	SQ.M.		
1043	PVC DOORS AND FRAMES		4.73	SQ.M.		
1722(1)	FENCE AND RAILINGS		35.30	SQ.M.		
1047	METAL STRUCTURES (TRUSSES, PURLINS, BOLTS, CROSS BRACING, AND STEEL PLATES)		1.00	LUMP SUM		
1003(1)a1	CEILING (MARINE PLYWOOD ON METAL FRAME)		106.72	SQ.M.		
1013(2)	FABRICATED METAL ROOFING ACCESSORIES		76.88	L.M.		
1014(1)b2	PRE-PAINTED METAL SHEETS		224.00	SQ.M.		

1100	CONDUITS, BOXES, AND FITTINGS (CONDUITS ROUGH-IN)		177.70	L.M.		
1101(33)	WIRES AND WIRING DEVICE		1.00	LUMP SUM		
1102	POWER LOAD CENTER, SWITCHGEAR, AND PANEL BOARDS		1.00	SETS		
1103	LIGHTINGS FIXTURES		20.00	SETS		
1002(2)	PLUMBING PPR-C PIPES		28.05	L.M.		
1002(4)	PLUMBING FIXTURES AND FITTINGS		13.00	SET/S		
1001	STORM DRAINAGE AND SEWERAGE SYSTEM		68.10	L.M.		
TOTAL BID COST						
BREAKDOWN OF BID COST:						TOTAL COST
A.	DIRECT COST					
	EQUIPMENT					
	LABOR					
	MATERIALS					
B.	INDIRECT COST					
	OCM					
	CONTRACTOR'S PROFIT					
	TAXES					
C.	PROJECT COST(TOTAL A+B)					
ESTIMATED PROJECT COST (EPC)						

TOTAL BID COST (IN FIGURES)

TOTAL BID AMOUNT IN WORDS:

I hereby submit the foregoing bid; and that I understood the terms and conditions and the content.

NAME OF BIDDER/CONTRACTOR

NAME OF CONSTRUCTION FIRM/ COMPANY: _____

DATE: _____

PART B: OTHER GENERAL REQUIREMENTS

ITEM NO.: B.3 UNIT: LUMP SUM
 DESCRIPTION: PERMITS AND CLEARANCES (BUILDING PERMITS) QUANTITY: 1.00

	DESCRIPTION	QTY	DAYS	UNIT COST	AMOUNT
A.	Equipment Rental: (To include Operators, Helpers, Fuel and Lubricants)				
a.	None	-	-	-	-
				Equipment Total	-
B.	Labor				
a.	None	-	-	-	-
					-
C.	Materials				
a.	Permit Fees(Includes Sign and Seal of Professionals)	1	lump sump		
				Material Total	

D. DIRECT COST(A+B+C)

E. OCM 0% DIRECT COST

F. Contractor's Profit 0% DIRECT COST

G. Tax 5% (DC+OCM+CP)

H. INDIRECT COST (E+F+G)

I. TOTAL ITEM COST(D+H)

Unit Cost/lump sum

PART B: OTHER GENERAL REQUIREMENTS

ITEM NO.:	B.7	UNIT:	LUMP SUM
DESCRIPTION:	OCCUPATIONAL SAFETY AND HEALTH PROGRAM	QUANTITY:	1.00

DESCRIPTION	QTY	DAYS	UNIT COST	AMOUNT
A. Equipment Rental: (To include Operators, Helpers, Fuel and Lubricants)				
a. None				
			Equipment Total	
B. Labor				
a. Safety Practitioner/ Officer (Part Time)				
b. None				
			Skilled Sub Total	
			Unskilled Sub Total	
			Labor Total	
C. Materials				
a. Safety Helmet	30	man-days		
b. Safety Shoes	10	man-days		
c. Safety Gloves	15	man-days		
d. Reflectorized Vest	60	man-days		
e. Rain Coats	10	man-days		
f. Dust Mask	2	man-days		
g. Eye Goggles	2	man-days		
h. Ear Muff	2	man-days		
i. Body Harness and Lanyard	2	man-days		
j. Rubber Boots	4	man-days		
k. Safety First Signage (2' x 3')	2	sets		
l. Warning Signs (2' x 3')	1	sets		
m. Caution Tape, 100ft	1	rolls		
n. Safety Net (1/8" x 2.7m x 90m)or Approved Equivalent	1	rolls		
			Material Total	

D. DIRECT COST(A+B+C)

E. OCM

DIRECT COST

F. Contractor's Profit

DIRECT COST

G. Tax

5% (DC+OCM+CP)

H. INDIRECT COST (E+F+G)

I. TOTAL ITEM COST(D+H)

Unit Cost/lump sum

PART B: OTHER GENERAL REQUIREMENTS

ITEM NO.:	B.9	UNIT:	LUMP SUM
DESCRIPTION:	MOBILIZATION / DEMOBILIZATION	QUANTITY:	1.00

	DESCRIPTION	QTY	DAYS	UNIT COST	AMOUNT
A.	Equipment Rental: (To include fuel, oil, lubricants, and equipment maintenance)				
a.	None				
				Equipment Total	
B.	Labor				
a.	None				
				Skilled Sub Total	
b.	None				
				Unskilled Sub Total	
				Labor Total	
C.	Materials				
a.	None				
				Material Total	

In No case that the Mob. And Demob. Exceeds 1% of Estimated Direct Cost (EDC) of the Civil Work items.

D. DIRECT COST(A+B+C)	DIRECT COST	_____
E. OCM	DIRECT COST	_____
F. Contractor's Profit	DIRECT COST	_____
G. Tax	5% (DC+OCM+CP)	_____
H. INDIRECT COST (E+F+G)		_____
I. TOTAL ITEM COST(D+H)		_____
	Unit Cost/lump sum	_____

PART A: EARTHWORKS

ITEM NO.:	801(1)	UNIT:	LUMP SUM
DESCRIPTION:	REMOVAL OF STRUCTURES AND OBSTRUCTION	QUANTITY:	1

DESCRIPTION	QTY	DAYS	UNIT COST	AMOUNT
A. Equipment Rental(To include fuel, oil, lubricants, and equipment maintenance)				
a. Jackhammer				
b. Concrete Saw				
c. Minor Tools (10% of Labor Cost)				
			Equipment Total	
B. Labor:				
a. Leadman				
b. Jackhammer Operator				
c. Concrete Saw Driver/operator				
			Skilled Sub-Total	
d. Laborers				
			Unskilled Sub-Total	
			Labor Total	
C. Materials				
a. None				
			Material Total	

D. DIRECT COST(A+B+C)		_____
E. OCM	DIRECT COST	_____
F. Contractor's Profit	DIRECT COST	_____
G. Tax	5% (DC+OCM+CP)	_____
H. INDIRECT COST(E+F+G)		_____
I. TOTAL ITEM COST(D+H)		_____
	Unit Cost/lump sum	_____

PART A: EARTHWORKS

ITEM NO.:	803(1)a	UNIT:	CU.M.
DESCRIPTION:	STRUCTURE EXCAVATION (COMMON SOIL)	QUANTITY:	1.70

	DESCRIPTION	QTY	DAYS	UNIT COST	AMOUNT
A.	Equipment Rental(To include fuel, oil, lubricants, and equipment maintenance)				
a.	Minor Tools (10% of Labor Cost)				
				Equipment Total	
B.	Labor				
a.	Leadman				
b.	Skilled Laborers				
				Skilled Sub-Total	
d.	Laborers				
				Unskilled Sub-Total	
				Labor Total	
C.	Materials				
a.	None				
				Material Total	

D. DIRECT COST(A+B+C)	DIRECT COST	_____
E. OCM	DIRECT COST	_____
F. Contractor's Profit	DIRECT COST	_____
G. Tax	5% (DC+OCM+CP)	_____
H. INDIRECT COST(E+F+G)		_____
I. TOTAL ITEM COST(D+H)		_____
	Unit Cost/cu.m.	_____

PART A: EARTHWORKS

ITEM NO.:	804(1)a	UNIT:	CU.M.
DESCRIPTION:	EMBANKMENT FROM THE EXCAVATION	QUANTITY:	1.70

DESCRIPTION	QTY	DAYS	UNIT COST	AMOUNT
A. Equipment Rental(To include fuel, oil, lubricants, and equipment maintenance)				
a. Minor Tools (10% of Labor Cost)				
			Equipment Total	
B. Labor:				
a. Leadman				
c. Skilled Laborers				
			Skilled Sub-Total	
d. Laborers				
			Unskilled Sub-Total	
			Labor Total	
C. Materials				
a. None				
			Material Total	

D. DIRECT COST(A+B+C)

E. OCM

DIRECT COST

F. Contractor's Profit

DIRECT COST

G. Tax

5% (DC+OCM+CP)

H. INDIRECT COST(E+F+G)

I. TOTAL ITEM COST(D+H)

Unit Cost/cu.m.

PART A: EARTHWORKS

ITEM NO.:	804(1)b	UNIT:	CU.M.
DESCRIPTION:	EMBANKMENT FROM COMMON BORROW BY EQUIPMENT	QUANTITY:	33.6

DESCRIPTION	QTY	DAYS	UNIT COST	AMOUNT
A. Equipment Rental(To include fuel, oil, lubricants, and equipment maintenance)				
a. Cargo/ Service Truck				
b. Plate Compactor (5 PH)				
c. Minor Tools (10% of Labor Cost)				
			Equipment Total	
B. Labor:				
a. Leadman				
b. Cargo/ Service Truck Operator				
c. Plate Compactor (5 PH) Operator				
			Skilled Sub-Total	
d. Laborers				
			Unskilled Sub-Total	
			Labor Total	
C. Materials				
a. Common Borrow (w/ 25% shrinkage factor)	42	cu.m.		
			Material Total	

D. DIRECT COST(A+B+C)	DIRECT COST	_____
E. OCM	DIRECT COST	_____
F. Contractor's Profit	DIRECT COST	_____
G. Tax	5% (DC+OCM+CP)	_____
H. INDIRECT COST(E+F+G)		_____
I. TOTAL ITEM COST(D+H)		_____
	Unit Cost/cu.m.	_____

PART A: EARTHWORKS

ITEM NO.:	804(4)	UNIT:	CU.M.
DESCRIPTION:	GRAVEL BEDDING	QUANTITY:	8.0

	DESCRIPTION	QTY	HOURS	UNIT COST	AMOUNT
A.	Equipment Rental(To include fuel, oil, lubricants, and equipment maintenance)				
a.	Minor Tools (10% of Labor Cost)				
				Equipment Total	
B.	Labor:				
a.	Leadman				
b.	Skilled Laborers				Skilled Sub-Total
c.	Laborers				Unskilled Sub-Total
					Labor Total
C.	Materials				
a.	Gravel Bedding (G1)	8.4	cu.m.		
					Material Total

D. DIRECT COST(A+B+C)

E. OCM

DIRECT COST

F. Contractor's Profit

DIRECT COST

G. Tax

5% (DC+OCM+CP)

H. INDIRECT COST(E+F+G)

I. TOTAL ITEM COST(D+H)

Unit Cost/cu.m.

PART B: PLAIN AND REINFORCED CONCRETE WORK

ITEM NO.:	900	UNIT:	CU.M.
DESCRIPTION:	STRUCTURAL CONCRETE (3500 PSI @ 28 DAYS)	QUANTITY:	31.00

DESCRIPTION	QTY	DAYS	UNIT COST	AMOUNT
A. Equipment Rental(To include fuel, oil, lubricants, and equipment maintenance)				
a. One Bagger Mixer				
b. Minor Tools (10% of Labor Cost)				
			Equipment Total	
B. Labor:				
a. Construction Foreman				
b. Skilled Laborers				
			Skilled Sub-Total	
c. Laborers				
			Unskilled Sub-Total	
			Labor Total	
C. Materials				
a. Cement	285	bags		
b. Sand	16	cu.m.		
c. Gravel	31	cu.m.		
			Material Total	

D. DIRECT COST(A+B+C)	_____
E. OCM	DIRECT COST _____
F. Contractor's Profit	DIRECT COST _____
G. Tax	5% (DC+OCM+CP) _____
H. INDIRECT COST(E+F+G)	_____
I. TOTAL ITEM COST(D+H)	_____
	Unit Cost/cu.m. _____

PART B: PLAIN AND REINFORCED CONCRETE WORK

ITEM NO.:	902(1)	UNIT:	KGS.
DESCRIPTION:	REINFORCING STEEL OF REINFORCED CONCRETE STRUCTURES	QUANTITY:	6534.06

DESCRIPTION	QTY	DAYS	UNIT COST	AMOUNT
A. Equipment Rental (To include fuel, oil, lubricants, and equipment maintenance)				
a. Bar Cutter				
b. Bar Bender				
c. Minor Tools (10% of Labor Cost)				
			Equipment Total	
B. Labor:				
a. Leadman				
b. Skilled Laborers				
			Skilled Sub-Total	
c. Laborers				
			Unskilled Sub-Total	
			Labor Total	
C. Materials				
a. 16mm Dia. RSB Deformed (GRADE40)	2646	kgs.		
b. 12mm Dia. RSB Deformed (GRADE40)	949	kgs.		
c. 10mm Dia. RSB Deformed (GRADE33)	2939	kgs.		
d. #16 Galvanized Iron Wire	98	kgs.		
e. Miscellaneous (3% material cost)	1	lump sum		
			Material Total	

D. DIRECT COST(A+B+C)

E. OCM

DIRECT COST

F. Contractor's Profit

DIRECT COST

G. Tax

5% (DC+OCM+CP)

H. INDIRECT COST(E+F+G)

I. TOTAL ITEM COST(D+H)

Unit Cost/kgs.

PART B: PLAIN AND REINFORCED CONCRETE WORK

ITEM NO.:	903(2)	UNIT:	SQ.M.
DESCRIPTION:	FORMS AND FALSEWORKS	QUANTITY:	227.39

DESCRIPTION	QTY	DAYS	UNIT COST	AMOUNT
A. Equipment Rental (To include fuel, oil, lubricants, and equipment maintenance)				
a. H-Frame 1.7m x 1.2m, set:				
2pcs. H-Frames				
4pcs. Diagonal Cross Braces				
4pcs. Horizontal Braces				
8pcs. Joint Pins				
b. Shoring Jack, 3.8m Full Extension				
c. Adjustable U-head Jack, 0.6m				
d. Adjustable Base Jack, 0.6m				
e. 1-1/2" GI Pipe x 6m				
f. 1-1/2" GI Pipe x 3m				
g. 1-1/2" GI Pipe x 4m				
h. 1-1/2" GI Pipe x 1m				
i. Tie Rod x 0.6m				
j. Round Wing Nut				
			Equipment Total	
B. Labor:				
Fabrication				
a. Leadman				
b. Skilled Laborers				
c. Laborers				
			Skilled Sub-Total	
			Unskilled Sub-Total	
Installation				
a. Skilled Laborers				
b. Laborers				
			Skilled Sub-Total	
			Unskilled Sub-Total	
Stripping				
a. Skilled Laborers				
b. Laborers				
			Skilled Sub-Total	
			Unskilled Sub-Total	
			Labor Total	
C. Materials				
a. Good Lumber-5Uses	214.97	bd.ft.		
b. Marine Plywood (1/4" thk. x 1.2m x 2.44m) 4 uses	20	pcs.		
c. CWN(assorted)	47.30	kg.		
d. Consumables(5% of Material Cost)	1	lump sum		
			Material Total	

D. DIRECT COST(A+B+C)		_____
E. OCM	DIRECT COST	_____
F. Contractor's Profit	DIRECT COST	_____
G. Tax	5% (DC+OCM+CP)	_____
H. INDIRECT COST(E+F+G)		_____
I. TOTAL ITEM COST(D+H)		_____
	Unit Cost/sq.m.	_____

PART C: FINISHINGS AND OTHER CIVIL WORKS

ITEM NO.:	1046 (2)a1	UNIT:	SQ.M.
DESCRIPTION:	CHB NON LOAD BEARING, 100MM - 150MM (INCLUDING REINFORCING STEEL)	QUANTITY:	172.63

DESCRIPTION	QTY.	DAYS	UNIT COST	AMOUNT
A. Equipment Rental: (To include Operators, Helpers, Fuel & Lubricants)				
a. Minor Tools				
Equipment Total				
B. Labor:				
a. Leadman				
b. Skilled Laborers			Skilled Sub-Total	
c. Laborers			Unskilled Sub-Total	
Labor Total				
C. Materials:				
a. CHB Ordinary (5" thk)	1119	pcs.		
b. CHB Ordinary (4" thk)	741	pcs.		
c. Portland Cement	91	bags		
d. Washed Sand	7	cu.m.		
e. 10mm Dia. RSB Deformed	559	kgs.		
f. #16 Galvanized Iron Wire	8.63	kgs.		
g. Miscellaneous	1	lump sum		
Materials Total				

D. DIRECT COST (A+B+C)

E. OCM of Direct Cost

F. Contractor's Profit of Direct Cost

G. Tax 5.00% of (DC + OCM +CP)

H. INDIRECT COST (E+F+G)

I. TOTAL ITEM COST (D+H)

Unit Cost/ sq.m.

PART C: FINISHINGS AND OTHER CIVIL WORKS

ITEM NO.:	1021	UNIT:	SQM.
DESCRIPTION:	FLOOR TOPPINGS	QUANTITY:	66.00

	DESCRIPTION	QTY	DAYS	UNIT COST	AMOUNT
A.	Equipment Rental(To include fuel, oil, lubricants, and equipment maintenance)				
a.	Minor Tools (10% of Labor Cost)				
				Equipment Total	
B.	Labor:				
a.	Leadman				
b.	Skilled Laborers				Skilled Sub-Total
c.	Laborers				Unskilled Sub-Total
					Labor Total
C.	Materials				
	STORAGE/ WEIGHING/ OFFICE/ WASH AREA				
a.	Portland Cement	20	bag/s		
b.	Sand	1.65	cu.m.		
					Material Total

D. DIRECT COST(A+B+C)	_____	
E. OCM	DIRECT COST	_____
F. Contractor's Profit	DIRECT COST	_____
G. Tax	5% (DC+OCM+CP)	_____
H. INDIRECT COST(E+F+G)		_____
I. TOTAL ITEM COST(D+H)		_____
	Unit Cost/sq.m.	_____

PART C: FINISHINGS AND OTHER CIVIL WORKS

ITEM NO.:	1027(1)	UNIT:	SQ.M.
DESCRIPTION:	CEMENT PLASTER FINISH	QUANTITY:	349.835

DESCRIPTION	QTY	DAYS	UNIT COST	AMOUNT
A. Equipment Rental(To include fuel, oil, lubricants, and equipment maintenance)				
a. Minor Tools (10% of Labor Cost)				
			Equipment Total	
B. Labor:				
a. Leadman				
b. Skilled Laborers				Skilled Sub-Total
c. Laborers				Unskilled Sub-Total
				Labor Total
C. Materials				
a. Cement	105	bags.		
b. Sand	8.75	cu.m.		
				Material Total

D. DIRECT COST(A+B+C)

E. OCM

DIRECT COST

F. Contractor's Profit

DIRECT COST

G. Tax

5% (DC+OCM+CP)

H. INDIRECT COST(E+F+G)

I. TOTAL ITEM COST(D+H)

Unit Cost/sq.m.

PART C: FINISHINGS AND OTHER CIVIL WORKS

ITEM NO.:	1018(1)	UNIT:	SQM.
DESCRIPTION:	GLAZED TILES AND TRIMS	QUANTITY:	25.34

DESCRIPTION	QTY	DAYS	UNIT COST	AMOUNT
A. Equipment Rental(To include fuel, oil, lubricants, and equipment maintenance)				
a. Minor Tools (10% of Labor Cost)				
			Equipment Total	
B. Labor:				
a. Leadman				
b. Skilled Laborers				Skilled Sub-Total
c. Laborers				Unskilled Sub-Total
				Labor Total
C. Materials				
CR/ SHOWER/ WASH AREA				
a. 30cm x 30cm Glazed Tiles	282	pcs.		
b. Cement	8	bag/s		
c. Sand	0.66	cu.m.		
d. Tile Adhesive (25kg)	4	bag/s		
e. Tile Grout	3	bag/s		
f. Elastomeric Water Proofing Paint or Equivalent	1	liter		
g. Miscellaneous (3% material cost)	1	lump sum		
				Material Total
				-

D. DIRECT COST(A+B+C)

E. OCM

DIRECT COST

F. Contractor's Profit

DIRECT COST

G. Tax

5% (DC+OCM+CP)

H. INDIRECT COST(E+F+G)

I. TOTAL ITEM COST(D+H)

Unit Cost/sq.m.

PART C: FINISHINGS AND OTHER CIVIL WORKS

ITEM NO.:	1018(2)	UNIT:	SQM.
DESCRIPTION:	UNGLAZED TILES	QUANTITY:	41

DESCRIPTION	QTY	DAYS	UNIT COST	AMOUNT
A. Equipment Rental(To include fuel, oil, lubricants, and equipment maintenance)				
a. Minor Tools (10% of Labor Cost)				
			Equipment Total	
B. Labor:				
a. Leadman				
b. Skilled Laborers				
			Skilled Sub-Total	
c. Laborers				
			Unskilled Sub-Total	
			Labor Total	
C. Materials				
CR/ SHOWER/ LOBBY				
a. 40cm x 40cm Unglazed Tiles	254	pcs.		
b. Cement	13	bag/s		
c. Sand	1.06	cu.m.		
d. Tile Adhesive (25kg)	6	bag/s		
e. Tile Grout	5	bag/s		
f. Elastomeric Water Proofing Paint or Equivalent	1	liter		
g. Miscellaneous (3% material cost)	1	lump sum		
			Material Total	

D. DIRECT COST(A+B+C)		
E. OCM	DIRECT COST	_____
F. Contractor's Profit	DIRECT COST	_____
G. Tax	5% (DC+OCM+CP)	_____
H. INDIRECT COST(E+F+G)		_____
I. TOTAL ITEM COST(D+H)		_____
	Unit Cost/sq.m.	_____

PART C: FINISHINGS AND OTHER CIVIL WORKS

ITEM NO.:	1003 (2) b3	UNIT:	SQ.M.
DESCRIPTION:	DRYWALL (METAL FRAME AND FIBER CEMENT BOARD)	QUANTITY:	43.58

DESCRIPTION	QTY.	DAYS	UNIT COST	AMOUNT
A. Equipment Rental: (To include Operators, Helpers, Fuel & Lubricants)				
a. Minor Tools				
Equipment Total				
B. Labor:				
a. Leadman				
b. Skilled Laborers				
Skilled Sub-Total				
c. Laborers				
Unskilled Sub-Total				
Labor Total				
C. Materials:				
a. Metal Stud 32mm x 76 mm x 3m, 0.8mm thk.	51	pcs.		
b. Top and Bottom Metal Track 32mm x 76mm x3m, 0.8mm thk.	12	pcs.		
c. Header Metal Track 35mm x 76mm x3m, 0.8mm thk.	3	pcs.		
d. (Hardflex)Fiber Cement Board 1.2m x 2.4m x 4.5mm thk	30	pcs.		
e. Blind Rivets	610	pcs.		
f. Masonry Screws	174	pcs.		
g. Consumables,(cutting disk, etc...)	1	lump sum		
Materials Total				

D. DIRECT COST (A+B+C)

E. OCM of Direct Cost

F. Contractor's Profit of Direct Cost

G. Tax 5% of (DC + OCM +CP)

H. INDIRECT COST (E+F+G)

I. TOTAL ITEM COST (D+H)

Unit Cost/ sq.m.

PART C: FINISHINGS AND OTHER CIVIL WORKS

ITEM NO.:	1032	UNIT:	SQ.M.
DESCRIPTION:	PAINTING WORKS (MASONRY/CONCRETE, STEEL)	QUANTITY:	426.83

DESCRIPTION	QTY.	DAYS	UNIT COST	AMOUNT
A. Equipment Rental: (To include Operators, Helpers, Fuel & Lubricants)				
a. Minor Tools				
			Equipment Total	
B. Labor:				
a. Leadman				
b. Skilled Laborer			Skilled Sub-Total	
c. Laborers			Unskilled Sub-Total	
			Labor Total	
C. Materials:				
EXTERIOR WALL (FRONT)				
a. Concrete Neutralizer	4	gals.		
b. Acrylic Concrete Primer and Sealer	4	gals.		
c. Skim Coat or Approved Equivalent	5	bags		
d. Megacryl Latex - Semi-gloss	8	gals.		
INTERIOR WALLS(CHB WALL AND DRYWALL)				
e. Concrete Neutralizer	8	gals.		
f. Acrylic Primer	9	gals.		
g. Latex Putty (full putty) or Approved Equivalent	1	gals.		
h. Skim Coat or Approved Equivalent	8	bags		
i. Megacryl Latex - Semi-gloss	18	gals.		
CEILING(OFFICE/ LOBBY/ STORAGE/ WEIGHING AREA/ CR AND LAUNDRY)				
j. Acrylic Primer	4	gals.		
k. Latex Putty (full putty) or Approved Equivalent	5	gals.		
l. Megacryl Latex - Semi-gloss	9	gals.		
m. Consumables (Sand Paper, Rollers, Paint Brush, Tapes, etc.)	1	lump sum		
			Materials Total	

D. DIRECT COST (A+B+C)

E. OCM of Direct Cost

F. Contractor's Profit of Direct Cost

G. Tax 5.00% of (DC + OCM +CP)

H. INDIRECT COST (E+F+G)

I. TOTAL ITEM COST (D+H)

Unit Cost/ sq.m.

PART C: FINISHINGS AND OTHER CIVIL WORKS

ITEM NO.:	1007	UNIT:	SQ.M.
DESCRIPTION:	ALUMINUM FRAMED GLASS DOOR	QUANTITY:	13.65

DESCRIPTION	QTY	DAYS	UNIT COST	AMOUNT
A. Equipment Rental(To include fuel, oil, lubricants, and equipment maintenance)				
a. Minor Tools (10% of Labor Cost)				
			Equipment Total	
B. Labor:				
a. Leadman				
b. Skilled Laborers				
			Skilled Sub-Total	
c. Laborers				
			Unskilled Sub-Total	
			Labor Total	
C. Materials				
a. D-1 (Refer to Door Schedule)	4.2	sq.m.		
b. D-2 (Refer to Door Schedule)	3.78	sq.m.		
c. D-3 (Refer to Door Schedule)	3.78	sq.m.		
d. D-4 (Refer to Door Schedule)	1.9	sq.m.		
e. Consumables (1% material cost)	1	lump sum		
			Material Total	

D. DIRECT COST(A+B+C)	DIRECT COST	_____
E. OCM	DIRECT COST	_____
F. Contractor's Profit	DIRECT COST	_____
G. Tax	5% (DC+OCM+CP)	_____
H. INDIRECT COST(E+F+G)		_____
I. TOTAL ITEM COST(D+H)		_____
	Unit Cost/sqm.	_____

PART C: FINISHINGS AND OTHER CIVIL WORKS

ITEM NO.:	1008	UNIT:	SQM.
DESCRIPTION:	ALUMINUM GLASS WINDOWS	QUANTITY:	12.92

DESCRIPTION	QTY	DAYS	UNIT COST	AMOUNT
A. Equipment Rental(To include fuel, oil, lubricants, and equipment maintenance)				
a. Minor Tools (10% of Labor Cost)				
			Equipment Total	
B. Labor:				
a. Leadman				
b. Skilled Laborers				
			Skilled Sub-Total	
c. Laborers				
			Unskilled Sub-Total	
			Labor Total	
C. Materials				
a. W-1 (Refer to Window Schedule)	1.32	sq.m.		
b. W-2 (Refer to Window Schedule)	5.76	sq.m.		
c. W-3 (Refer to Window Schedule)	1.44	sq.m.		
d. W-4 (Refer to Window Schedule)	2	sq.m.		
e. W-5 (Refer to Window Schedule)	2.4	sq.m.		
f. Consumables (1% material cost)	1	lump sum		
			Material Total	

D. DIRECT COST(A+B+C)

E. OCM

F. Contractor's Profit

G. Tax

H. INDIRECT COST(E+F+G)

I. TOTAL ITEM COST(D+H)

DIRECT COST
 DIRECT COST
 5% (DC+OCM+CP)

Unit Cost/sqm.

PART C: FINISHINGS AND OTHER CIVIL WORKS

ITEM NO.:	1043	UNIT:	SQ.M.
DESCRIPTION:	PVC DOORS AND FRAMES	QUANTITY:	4.73

	DESCRIPTION	QTY	DAYS	UNIT COST	AMOUNT
A.	Equipment Rental(To include fuel, oil, lubricants, and equipment maintenance)				
a.	Minor Tools (10% of Labor Cost)				
				Equipment Total	
B.	Labor:				
a.	Leadman				
b.	Skilled Laborers				Skilled Sub-Total
c.	Laborers				Unskilled Sub-Total
					Labor Total
C.	Materials				
a.	D-5 (Refer to Door Schedule)	4.73	sq.m.		
b.	Consumables	1	lump sum		
					Material Total

D. DIRECT COST(A+B+C)		_____
E. OCM	DIRECT COST	_____
F. Contractor's Profit	DIRECT COST	_____
G. Tax	5% (DC+OCM+CP)	_____
H. INDIRECT COST(E+F+G)		_____
I. TOTAL ITEM COST(D+H)		_____
	Unit Cost/sqm.	_____

PART C: FINISHINGS AND OTHER CIVIL WORKS

ITEM NO.:	1722(1)	UNIT:	SQ.M.
DESCRIPTION:	FENCE AND RAILINGS	QUANTITY:	35.30

DESCRIPTION	QTY.	DAYS	UNIT COST	AMOUNT
A. Equipment Rental: (To include Operators, Helpers, Fuel & Lubricants)				
a. Minor Tools				
b. Welding Machine				
			Equipment Total	
B. Labor:				
a. Leadman				
b. Skilled Laborers				Skilled Sub-Total
c. Laborers				Unskilled Sub-Total
			Labor Total	
C. Materials:				
a. 1" x 4' x 58' Wire Mesh G1X4	2	roll		
b. 50mm x 50mm x 5mm x 5m Angle Bar	5	pcs.		
c. 25mm x 25mm x 5mm x 6m Angle Bar	8	pcs.		
d. Welding Rod	27	kgs.		
e. Cutting Disc	2	pcs.		
PEDESTAL: 0.9 cu.m.				
f. Cement	11	bags		
g. Gravel	1	cum.		
h. Sand	0.45	cum.		
i. 10mm Dia. RSB Deformed (GRADE33)	180	kgs.		
j. #16 Galvanized Iron Wire	3	kgs.		
k. Good Lumber-5Uses	11.34	bd.ft.		
l. MAHINE PLYWOOD (1/4 INK. X 1.200 X 2.4400) 4	1	pcs.		
m. CWN(assorted)	2.50	kg.		
			Materials Total	

- D. DIRECT COST (A+B+C)
- E. OCM of Direct Cost
- F. Contractor's Profit of Direct Cost
- G. Tax 5% of (DC + OCM +CP)
- H. INDIRECT COST (E+F+G)
- I. TOTAL ITEM COST (D+H)

Unit Cost/ sq.m.

PART C: FINISHINGS AND OTHER CIVIL WORKS

ITEM NO.:	1047	UNIT:	LUMP SUM
DESCRIPTION:	METAL STRUCTURES (TRUSSES, PURLINS, BOLTS, CROSS BRACING, & STEEL PLATES)	QUANTITY:	1

	DESCRIPTION	QTY.	DAYS	UNIT COST	AMOUNT
A.	Equipment Rental: (To include Operators, Helpers, Fuel & Lubricants)				
a.	Welding Machine				
b.	Steel Cutter				
c.	Chain Block				
d.	Minor Tools				
	Equipment Total				
B.	Labor:				
a.	Leadman				
b.	Skilled Laborer				
	Skilled Sub-Total				
c.	Laborers				
	Unskilled Sub-Total				
	Labor Total				
C.	Materials:				
a.	50mm x 50mm x 5mm x 5m Structural Angle Bar	76	pcs.		
b.	25mm x 25mm x 5mm x 6m Structural Angle Bar	57	pcs.		
c.	75mm X 50mmX 1.2mm thk. C-Purlin (6m)	59.70	pcs.		
d.	Tekscrew 12x65mm (STEEL)	1194	pcs.		
e.	16mmΦ x 300mm Long Bent Anchor Bolts with N&W	60	pcs.		
f.	Welding Rod	80	kgs.		
g.	Oxygen (Content Only)	1	tanks		
h.	Acetylene (Content Only)	1	tanks		
i.	Red Lead Paint	1	gals.		
j.	16mm dia. X 50mm Bolts	60	pcs.		
k.	6mm Thick Steel Gusset Plate	1	lumpsum		
l.	25cm x 25cm x 12mm thk. Steel Base Plate	15	pcs.		
m.	Consumables (cutting disks, etc.)	1	lumpsum		
	Materials Total				

D. DIRECT COST (A+B+C)

E. OCM of Direct Cost

F. Contractor's Profit of Direct Cost

G. Tax 5.00% of (DC + OCM +CP)

H. INDIRECT COST (E+F+G)

I. TOTAL ITEM COST (D+H)

Unit Cost/ lump sum

PART C: FINISHINGS AND OTHER CIVIL WORKS

ITEM NO.:	1003 (1)b1	UNIT:	SQ.M.
DESCRIPTION:	CEILING (MARINE PLYWOOD ON METAL FRAME)	QUANTITY:	106.72

	DESCRIPTION	QTY.	DAYS	UNIT COST	AMOUNT
A.	Equipment Rental: (To include Operators, Helpers, Fuel & Lubricants)				
a.	Minor Tools				
Equipment Total					
B.	Labor:				
a.	Leadman				
b.	Skilled Laborer				Skilled Sub-Total
c.	Laborers				Unskilled Sub-Total
Labor Total					
C.	Materials:				
a.	12mm x 38mm x 0.7mm Metal Carrying Channel, 12mm x 50 mm x 0.5mm x 5m Metal Double Furring Channel (Nailer) with W-Clip and Rod Suspension G-Type Hanger with Adjustment Spring	107.00	sq.m.		
b.	1" Metal Black Screw	426.87	pcs.		
c.	Blind Rivets	1067.175	pcs.		
d.	2.4m X 1.2m X 1/4 " THK. Marine Plywood	37	pcs.		
e.	Miscellaneous (Cutting disc, Wires, Nails, etc.)	1	lump sum		
Materials Total					

D. DIRECT COST (A+B+C)

E. OCM of Direct Cost

F. Contractor's Profit of Direct Cost

G. Tax 5.00% of (DC + OCM +CP)

H. INDIRECT COST (E+F+G)

I. TOTAL ITEM COST (D+H)

Unit Cost/ sq.m.

PART C: FINISHINGS AND OTHER CIVIL WORKS

ITEM NO.:	1013 (2)	UNIT:	L.M.
DESCRIPTION:	FABRICATED METAL ROOFING ACCESSORIES	QUANTITY:	76.88

DESCRIPTION	QTY.	DAYS	UNIT COST	AMOUNT
A. Equipment Rental: (To include Operators, Helpers, Fuel & Lubricants)				
a. Minor Tools				
Equipment Total				
B. Labor:				
a. Leadman				
b. Skilled Laborer			Skilled Sub-Total	
c. Laborers			Unskilled Sub-Total	
Labor Total				
C. Materials:				
a. Pre-Painted Ridge Roll GA24(0.701mm) x 2.44m	14.59	1.m.		
b. Pre-Painted End Flashing GA24(0.701mm) x 2.44m	48.7	1.m.		
c. Pre-Painted Gutter GA24(0.701mm) x 2.44m	13.59	1.m.		
d. Blind Rivets (5/32 x 1/2)	407	pcs.		
e. Silicon Sealant	1	pcs.		
f. Miscellaneous (Wires, Nails, Cutting Disc etc.)	1	lumpsum		
Materials Total				

D. DIRECT COST (A+B+C)

E. OCM of Direct Cost

F. Contractor's Profit of Direct Cost

G. Tax 5.00% of (DC + OCM +CP)

H. INDIRECT COST (E+F+G)

I. TOTAL ITEM COST (D+H)

Unit Cost/ 1.m.

PART C: FINISHINGS AND OTHER CIVIL WORKS

ITEM NO.:	1014 (1)b1	UNIT:	SQ.M.
DESCRIPTION:	PRE-PAINTED METAL SHEETS	QUANTITY:	224.00

DESCRIPTION	QTY.	DAYS	UNIT COST	AMOUNT
A. Equipment Rental: (To include Operators, Helpers, Fuel & Lubricants)				
a. Minor Tools				
Equipment Total				
B. Labor:				
a. Leadman				
b. Skilled Laborer			Skilled Sub-Total	
c. Laborers			Unskilled Sub-Total	
Labor Total				
C. Materials:				
a. 0.40mm Thick Prepainted Corrugated Roofing Sheet Long Span 12ft	224	sq.m.		
b. 8mm thk. PE Foam Insulation 1-Sided	3	roll		
c. Tekcrew 12x65mm (STEEL)	2240	pcs.		
d. Silicon Sealant	2	pcs.		
e. Touch Up Paint	1	liter		
f. Blind Rivets (5/32 x 1/2)	3136	pcs.		
g. Miscellaneous	1	lump sum		
Materials Total				

D. DIRECT COST (A+B+C)

E. OCM of Direct Cost

F. Contractor's Profit of Direct Cost

G. Tax 5.00% of (DC + OCM +CP)

H. INDIRECT COST (E+F+G)

I. TOTAL ITEM COST (D+H)

Unit Cost/ sq.m.

PART D: ELECTRICAL WORKS

ITEM NO.:	1100	UNIT:	L.M.
DESCRIPTION:	CONDUITS, BOXES, AND FITTINGS (CONDUITS ROUGH-IN)	QUANTITY:	177.7

DESCRIPTION	QTY	DAYS	UNIT COST	AMOUNT
A. Equipment Rental(To include fuel, oil, lubricants, and equipment maintenance)				
a. Minor Tools (10% of Labor Cost)				
			Equipment Total	
B. Labor:				
a. Leadman				
b. Skilled Laborers				
			Skilled Sub-Total	
c. Laborers				
			Unskilled Sub-Total	
			Labor Total	
C. Materials				
a. UPVC Pipe 15mm x 3 m	17	pcs.		
b. UPVC Pipe 20mm x 3 m	42	pcs.		
c. UPVC Pipe 25mm x 3 m	1	pcs.		
d. Locknuts and Bushing	12	pcs.		
e. PVC- Adoptor-15mm	17	pcs.		
f. PVC- Adoptor-20mm	6	pcs.		
g. PVC- Adoptor-25mm	4	pcs.		
h. Utility Box Gauge #16 Surface Type	11	pcs.		
i. Junction Box Surface Type	6	pcs.		
j. Service Entrance Cap (25.4mm Dia.)	1	pcs.		
k. Secondary Rack Spool	1	sets		
l. 16mm Dia. x 2.4m Ground Rod	1	pc.		
m. Assorted Fittings	1	lot		
n. Consumables(Clamps,etc.)	1	lump sum		
			Material Total	

D. DIRECT COST(A+B+C)

E. OCM

DIRECT COST

F. Contractor's Profit

DIRECT COST

G. Tax

5% (DC+OCM+CP)

H. INDIRECT COST(E+F+G)

I. TOTAL ITEM COST(D+H)

Unit Cost/l.m.

PART D: ELECTRICAL WORKS

ITEM NO.:	1101(33)	UNIT:	LUMP SUM
DESCRIPTION:	WIRES AND WIRING DEVICE	QUANTITY:	1

	DESCRIPTION	QTY	DAYS	UNIT COST	AMOUNT
A.	Equipment Rental(To include fuel, oil, lubricants, and equipment maintenance)				
a.	Minor Tools (10% of Labor Cost)				
				Equipment Total	
B.	Labor:				
a.	Leadman				
b.	Skilled Laborers				Skilled Sub-Total
c.	Laborers				Unskilled Sub-Total
					Labor Total
C.	Materials				
a.	Electric Wire 3.5mm2 THWN/THHN	92.55	l.m.		
b.	Electric Wire 5.5mm2 THWN/THHN	13	l.m.		
c.	Electric Wire 2.0mm2 THWN/THHN	51.57	l.m.		
d.	Electric Wire 8.00mm2 THWN/THHN	20.4	l.m.		
e.	Electric Wire 14.0mm2 THWN/THHN	3	l.m.		
f.	One Gang Switch	9	set/s		
g.	Duplex Convenience Outlet Wide Series	9	set/s		
h.	Single Convenience Outlet Wide Series	2	set/s		
i.	Consumables (Electrical Tapes, etc.)	1	lump sum		
					Material Total

D. DIRECT COST(A+B+C)		_____
E. OCM	DIRECT COST	_____
F. Contractor's Profit	DIRECT COST	_____
G. Tax	5% (DC+OCM+CP)	_____
H. INDIRECT COST(E+F+G)		_____
I. TOTAL ITEM COST(D+H)		_____
	Unit Cost/lump sum	_____

PART D: ELECTRICAL WORKS

ITEM NO.:	1102	UNIT:	SET/S
DESCRIPTION:	POWER LOAD CENTER, SWITCHGEAR, AND PANELBOARDS	QUANTITY:	1.00

	DESCRIPTION	QTY.	DAYS	UNIT COST	AMOUNT
A.	Equipment Rental: (To include Operators, Helpers, Fuel & Lubricants)				
a.	Minor Tools				
Equipment Total					
B.	Labor:				
a.	Leadman				
b.	Skilled Laborer				
Skilled Sub-Total					
c.	Laborers				
Unskilled Sub-Total					
Labor Total					
C.	Materials:				
a.	Panel Board A (PBA) 6 Holes with 6-pcs. 15Amp, 2P, 230V CB with built in main Distribution Panel	1	set		
b.	Consumables (3% material cost)	1	lump sum		
Materials Total					

D. DIRECT COST (A+B+C)

E. OCM of Direct Cost

F. Contractor's Profit of Direct Cost

G. Tax 5.00% of (DC + OCM +CP)

H. INDIRECT COST (E+F+G)

I. TOTAL ITEM COST (D+H)

Unit Cost/ set

PART D: ELECTRICAL WORKS

ITEM NO.:	1103	UNIT:	SETS
DESCRIPTION:	LIGHTINGS FIXTURES	QUANTITY:	20

	DESCRIPTION	QTY	DAYS	UNIT COST	AMOUNT
A.	Equipment Rental(To include fuel, oil, lubricants, and equipment maintenance)				
a.	Minor Tools (10% of Labor Cost)				
				Equipment Total	
B.	Labor:				
a.	Leadman				
b.	Skilled Laborers				Skilled Sub-Total
c.	Laborers				Unskilled Sub-Total
					Labor Total
C.	Materials				
a.	25 Watts LED Lighting Fixture with 6" Dia. Medium Base, Keyless Type Porcelain Receptacle	15	set/s		
b.	1pcs. - T8 LED Tube Lighting Fixture (Daylight) w/ 2x40 Housing	5	sets		
c.	Consumables (Electrical Tapes, etc.)	1	lump sum		
					Material Total

D. DIRECT COST(A+B+C)		_____
E. OCM	DIRECT COST	_____
F. Contractor's Profit	DIRECT COST	_____
G. Tax	5% (DC+OCM+CP)	_____
H. INDIRECT COST(E+F+G)		_____
I. TOTAL ITEM COST(D+H)		_____
	Unit Cost/set	_____

PART C: FINISHINGS AND OTHER CIVIL WORKS

ITEM NO.:	1002(2)	UNIT:	L.M.
DESCRIPTION:	PLUMBING PPR-C PIPES	QUANTITY:	28.05

DESCRIPTION	QTY.	DAYS	UNIT COST	AMOUNT
A. Equipment Rental: (To include Operators, Helpers, Fuel & Lubricants)				
a. Minor Tools				
Equipment Total				
B. Labor:				
a. Leadman				
b. Skilled Laborer			Skilled Sub-Total	
c. Laborers			Unskilled Sub-Total	
Labor Total				
C. Materials:				
a. 20mm Dia. PPR-C Pipes- PN 20	6	l.m.		
b. 25mm Dia. PPR-C Pipes- PN 20	22.05	l.m.		
c. Assorted PPR Pipe Fittings of various Diameter	1	lumpsum		
d. Consumables (Teflon tape, etc...)	1	lumpsum		
Materials Total				

D. DIRECT COST (A+B+C)

E. OCM of Direct Cost

F. Contractor's Profit of Direct Cost

G. Tax 5.00% of (DC + OCM +CP)

H. INDIRECT COST (E+F+G)

I. TOTAL ITEM COST (D+H)

Unit Cost/ l.m.

PART C: FINISHINGS AND OTHER CIVIL WORKS

ITEM NO.:	1002(4)	UNIT:	SET/S
DESCRIPTION:	PLUMBING FIXTURES AND FITTINGS	QUANTITY:	13

DESCRIPTION	QTY.	DAYS	UNIT COST	AMOUNT
A. Equipment Rental: (To include Operators, Helpers, Fuel & Lubricants)				
a. Minor Tools				
			Equipment Total	
B. Labor:				
a. Leadman				
b. Skilled Laborer			Skilled Sub-Total	
c. Laborers			Unskilled Sub-Total	
			Labor Total	
C. Materials:				
a. Water Closet Including Handle Bar and Fittings and Accessories	2	sets		
b. Lavatory Including Fittings and Accessories	1	set		
c. Urinal Including Fittings and Accessories	1	set		
d. Shower Exposed with Complete Fittings and Accessories	1	set		
e. Stainless Floor Drain with Strainer	6	pcs.		
f. Stainless Kitchen Sink With Faucet and Complete Hardware and Accessories	2	sets		
g. Gate Valve	2	pcs.		
h. Assorted PPR Pipe Fittings of various Diameter	1	lumpsum		
i. Consumables (Teflon tape, etc...)	1	lumpsum		
			Materials Total	

D. DIRECT COST (A+B+C)

E. OCM of Direct Cost

F. Contractor's Profit of Direct Cost

G. Tax 5.00% of (DC + OCM +CP)

H. INDIRECT COST (E+F+G)

I. TOTAL ITEM COST (D+H)

Unit Cost/set/s

PART E: PLUMBING / SANITARY WORKS

ITEM NO.:	1001	UNIT:	L.M.
DESCRIPTION:	STORM DRAINAGE AND SEWERAGE SYSTEM	QUANTITY:	68.1

DESCRIPTION	QTY	DAYS	UNIT COST	AMOUNT
A. Equipment Rental (To include fuel, oil, lubricants, and equipment maintenance)				
a. Minor Tools (10% of Labor Cost)				
			Equipment Total	
B. Labor:				
a. Leadman				
b. Skilled Laborers				
			Skilled Sub-Total	
c. Laborers				
			Unskilled Sub-Total	
			Labor Total	
C. Materials				
a. 50mm Dia. x 3m PVC Pipe	21	pcs.		
b. 50mm Dia. PVC Assorted Fittings	1	lump sum		
c. 101mm Dia. x 3m PVC Pipe	2	pcs.		
d. 101mm Dia. PVC Assorted Fittings	1	lump sum		
e. Solvent Cement	1	can		
f. Consumables (5% material cost)	1	lump sum		
			Material Total	

D. DIRECT COST(A+B+C)	DIRECT COST	_____
E. OCM	DIRECT COST	_____
F. Contractor's Profit	DIRECT COST	_____
G. Tax	5% (DC+OCM+CP)	_____
H. INDIRECT COST(E+F+G)		_____
I. TOTAL ITEM COST(D+H)		_____
	Unit Cost/l.m.	_____

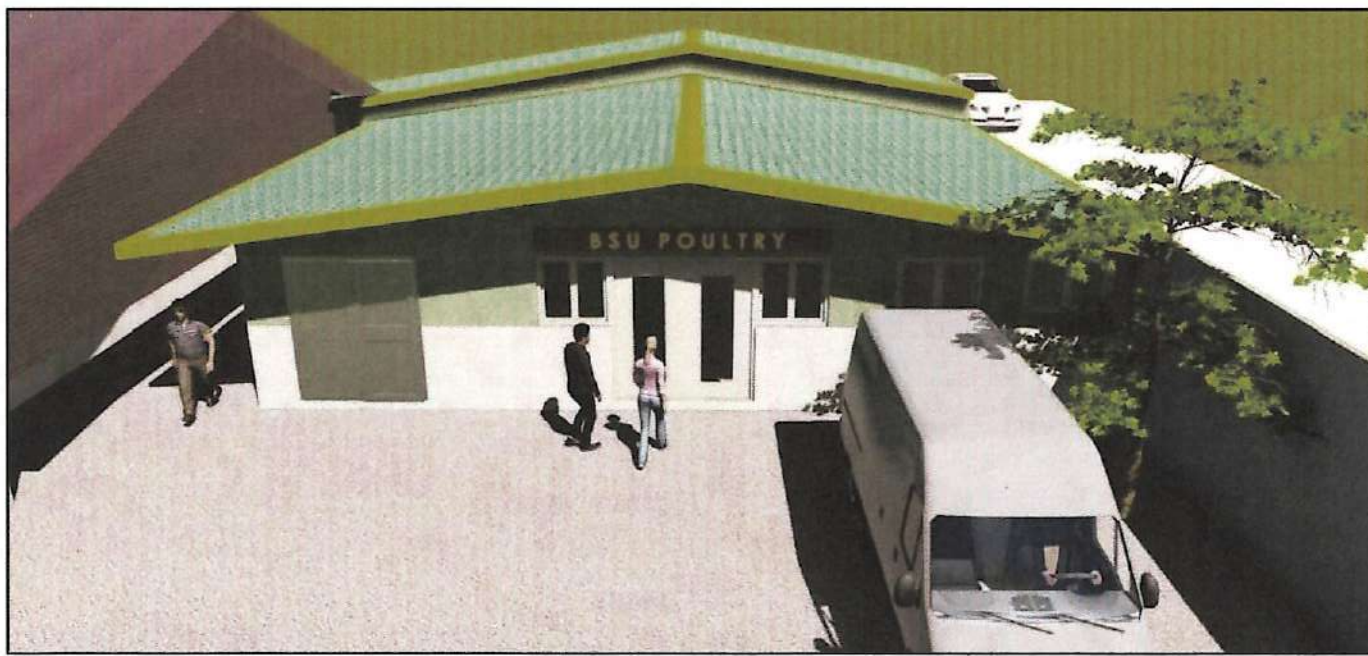

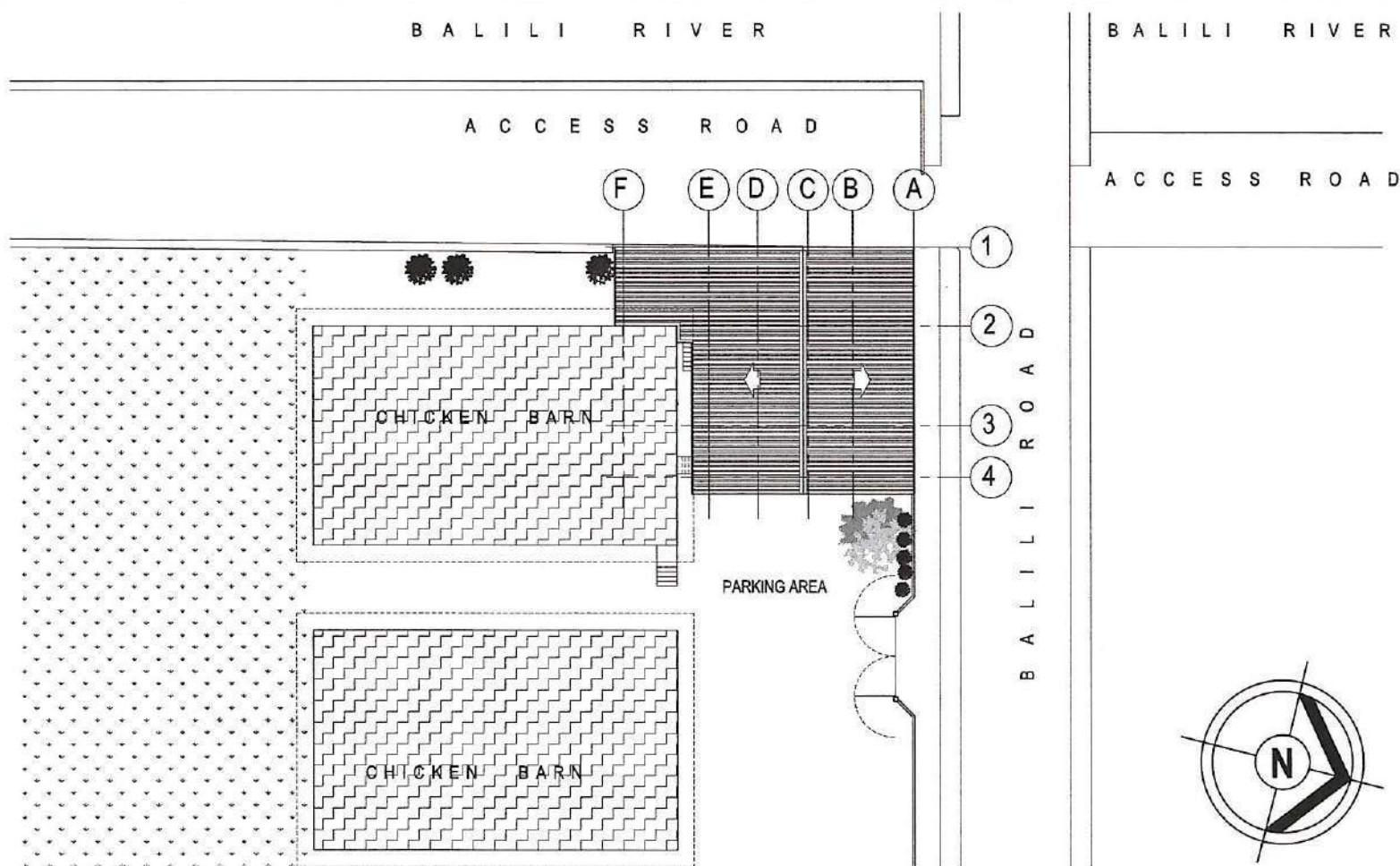

A EXTERIOR PERSPECTIVES
01/01 SCALE N.T.S.



A SITE DEVELOPMENT PLAN
01/01 SCALE 1:400 MTS.

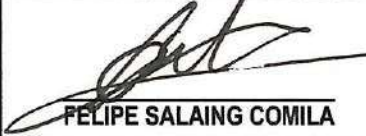

A VICINITY MAP
01/01 SCALE N.T.S.

<p>ARCH. HAZELINE N. TIBANGAY, UAP PRC REG. NO. 028540 - NOV.18, 2024 PTR NO. _____ - LA TRINIDAD - _____ ARCHITECT</p>	<p>ENGINEER</p>	<p>DRAFTED BY: ERGD 2024</p>	<p>OWNER/ PROJECT TITLE/ LOCATION  REPAIR OF THE POULTRY OFFICE BUILDING BSU LA TRINIDAD CAMPUS, BALILI, LA TRINIDAD, BENGUET</p>	<p>CONFORME:  BERNARD B. BALAG JR. END-USERS</p>	<p>RECOMMENDING APPROVAL:  ALLAN CASALDO SACPA SECTOR VICE PRESIDENT</p>	<p>APPROVED:  FELIPE SALAING COMILA PRESIDENT</p>	<p>SHEET CONTENT: AS SHOWN</p>	<p>SHEET A 00-06</p>
--	-----------------	----------------------------------	--	--	--	---	------------------------------------	-------------------------------------

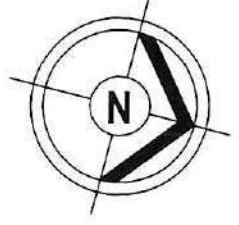

BALILI RIVER

ACCESS ROAD

ACCESS ROAD

F E D C B A

1

2

3

4

BALILI ROAD

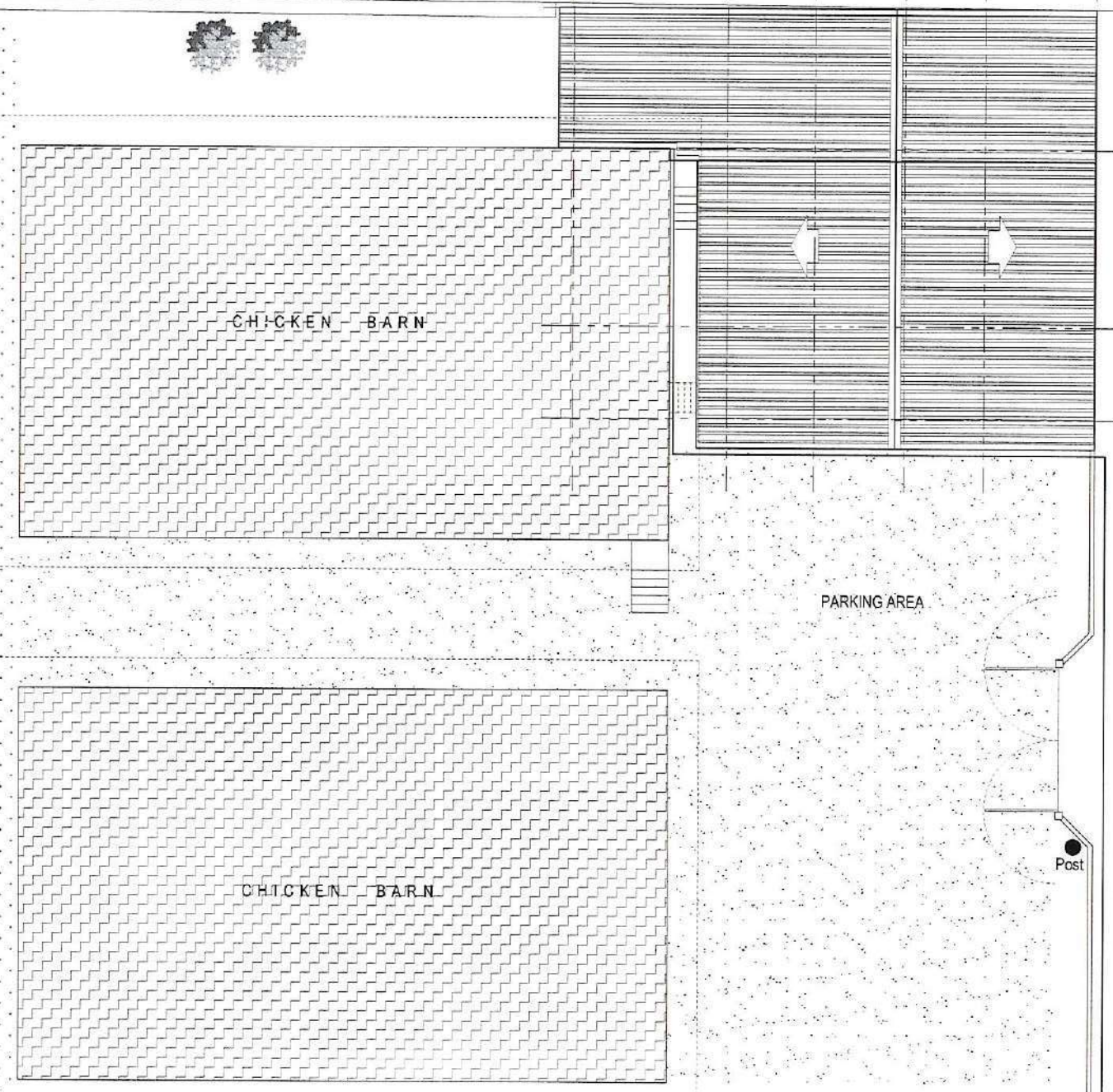

LEGENDS:	
EXISTING TREE	
EXISTING MEDIUM BUSHES	
EXISTING SMALL PLANTS	
EXISTING STRUCTURE	
UNPAVED GROUND	
ELECTRICAL SERVICE DROP POST	
WATER LINE	
DRAINAGE LINE	
WATER FLOW	

A SITE DEVELOPMENT PLAN
 01/01 SCALE 1:200 MTS.

 ARCH. HAZELINE N. TIBANGAY, UAP PRC REG. NO. 028540 - NOV. 18, 2024 PTR NO. - LA TRINIDAD - ARCHITECT	DRAFTED BY: ERGD 2024 ENGINEER	OWNER/ PROJECT TITLE/ LOCATION REPAIR OF THE POULTRY OFFICE BUILDING BSU LA TRINIDAD CAMPUS, BALILI, LA TRINIDAD, BENGUET	CONFORME: BERNARD B. BALAG JR. END-USERS	RECOMMENDING APPROVAL: ALLAN CASALDO SACPA SECTOR VICE PRESIDENT	APPROVED: FELIPE SALAING COMILA PRESIDENT	SHEET CONTENT: AS SHOWN	SHEET A 01-06

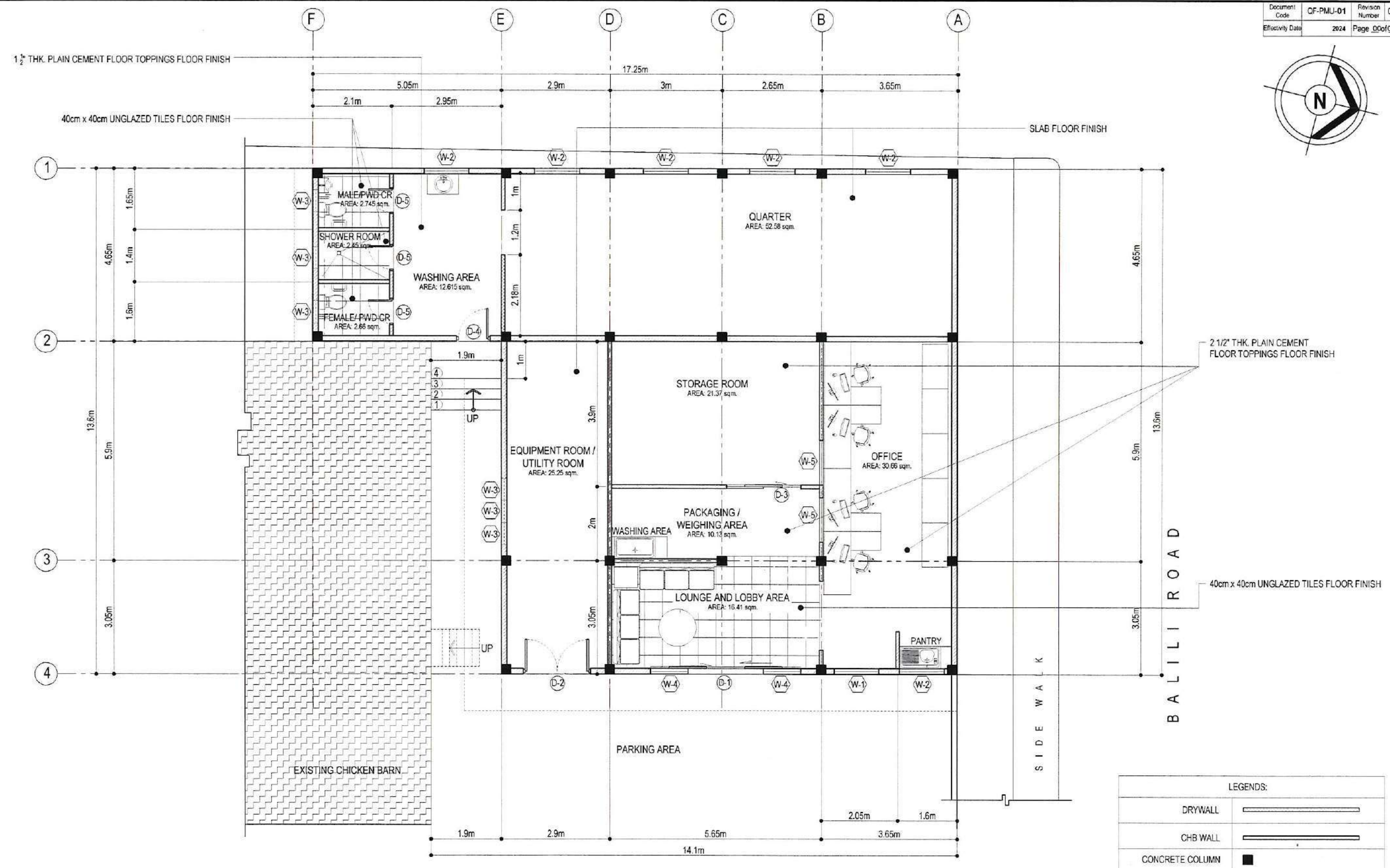
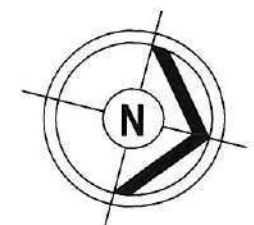



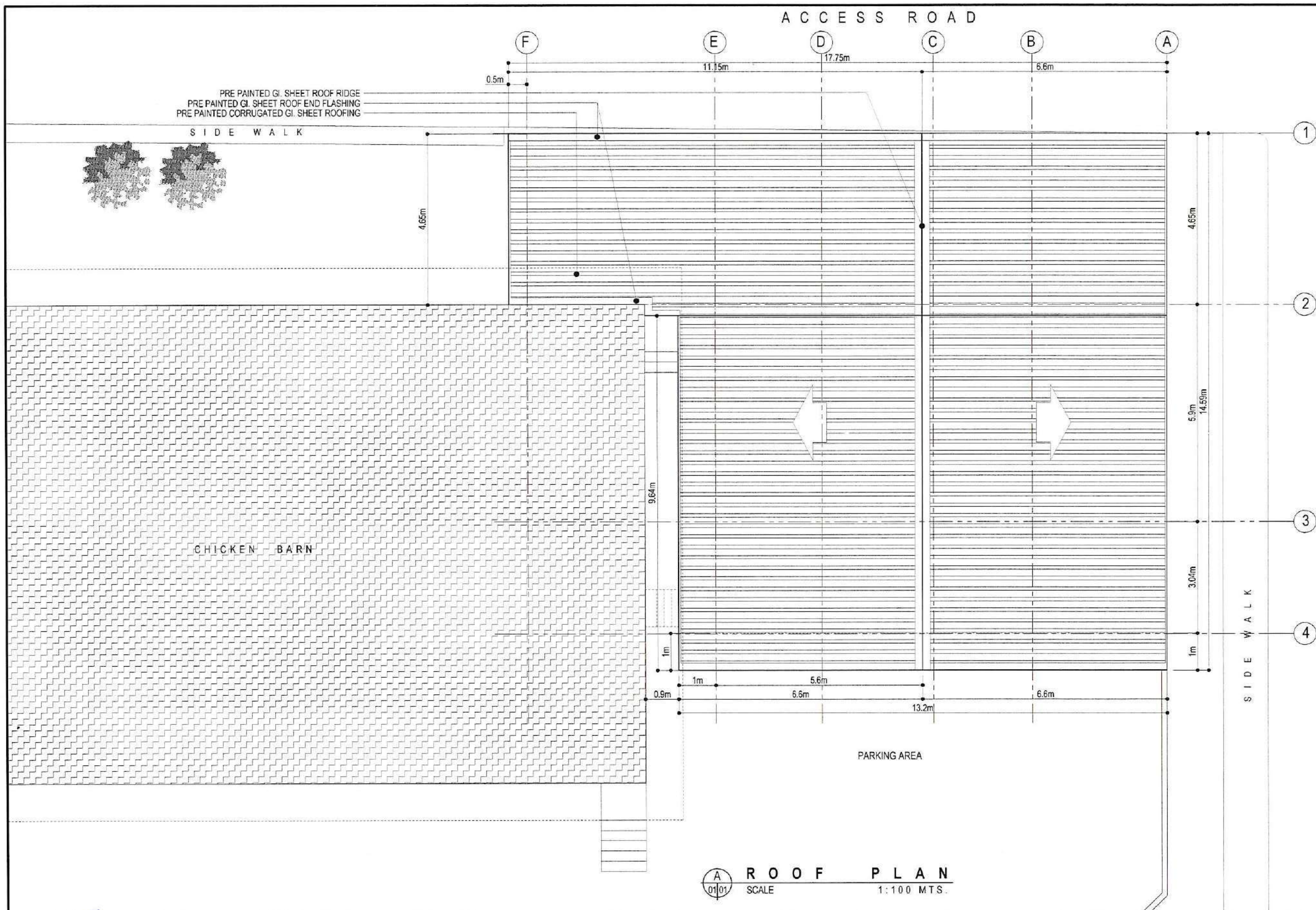
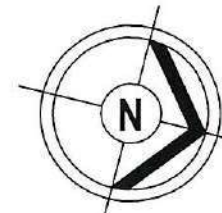

A FLOOR PLAN
 01/01 SCALE 1:100 MTS.

LEGENDS:	
DRYWALL	
CHB WALL	
CONCRETE COLUMN	
EXISTING STRUCTURE	

 ARCH. HAZE N. TIBANGAY, UAP PRC REG. NO. 028540 - NOV. 18, 2024 PTR NO. - LA TRINIDAD - ARCHITECT	DRAFTED BY: ERGD 2024 REPAIR OF THE POULTRY OFFICE BUILDING BSU LA TRINIDAD CAMPUS, BALILI, LA TRINIDAD, BENGUET	CONFORME: BERNARD B. BALAG JR. END-USERs	RECOMMENDING APPROVAL: ALLAN CASALDO SACPA SECTOR VICE PRESIDENT	APPROVED: FELIPE SALAING COMILA PRESIDENT	SHEET CONTENT: AS SHOWN	SHEET A 02-06
		ENGINEER	END-USERs	SECTOR VICE PRESIDENT	PRESIDENT	AS SHOWN



ROOF PLAN
 SCALE: 1:100 MTS.

<p>ARCH. HAZELINE N. TIBANGAY, UAP PRC REG. NO. 028540 - NOV.18, 2024 PTR NO. _____ - LA TRINIDAD - _____ ARCHITECT</p>	<p>ENGINEER</p>	<p>DRAFTED BY: ERGD 2024</p> <p> REPAIR OF THE POULTRY OFFICE BUILDING BSU LA TRINIDAD CAMPUS, BALILI, LA TRINIDAD, BENGUET</p>	<p>CONFORME:</p> <p> BERNARD B. BALAG JR. END-USERS</p>	<p>RECOMMENDING APPROVAL:</p> <p> ALLAN CASALDO SACPA SECTOR VICE PRESIDENT</p>	<p>APPROVED:</p> <p> FELIPE SALAING COMILA PRESIDENT</p>	<p>SHEET CONTENT:</p> <p>AS SHOWN</p>	<p>SHEET</p> <p>A 03-06</p>
--	-----------------	--	---	---	--	---------------------------------------	---

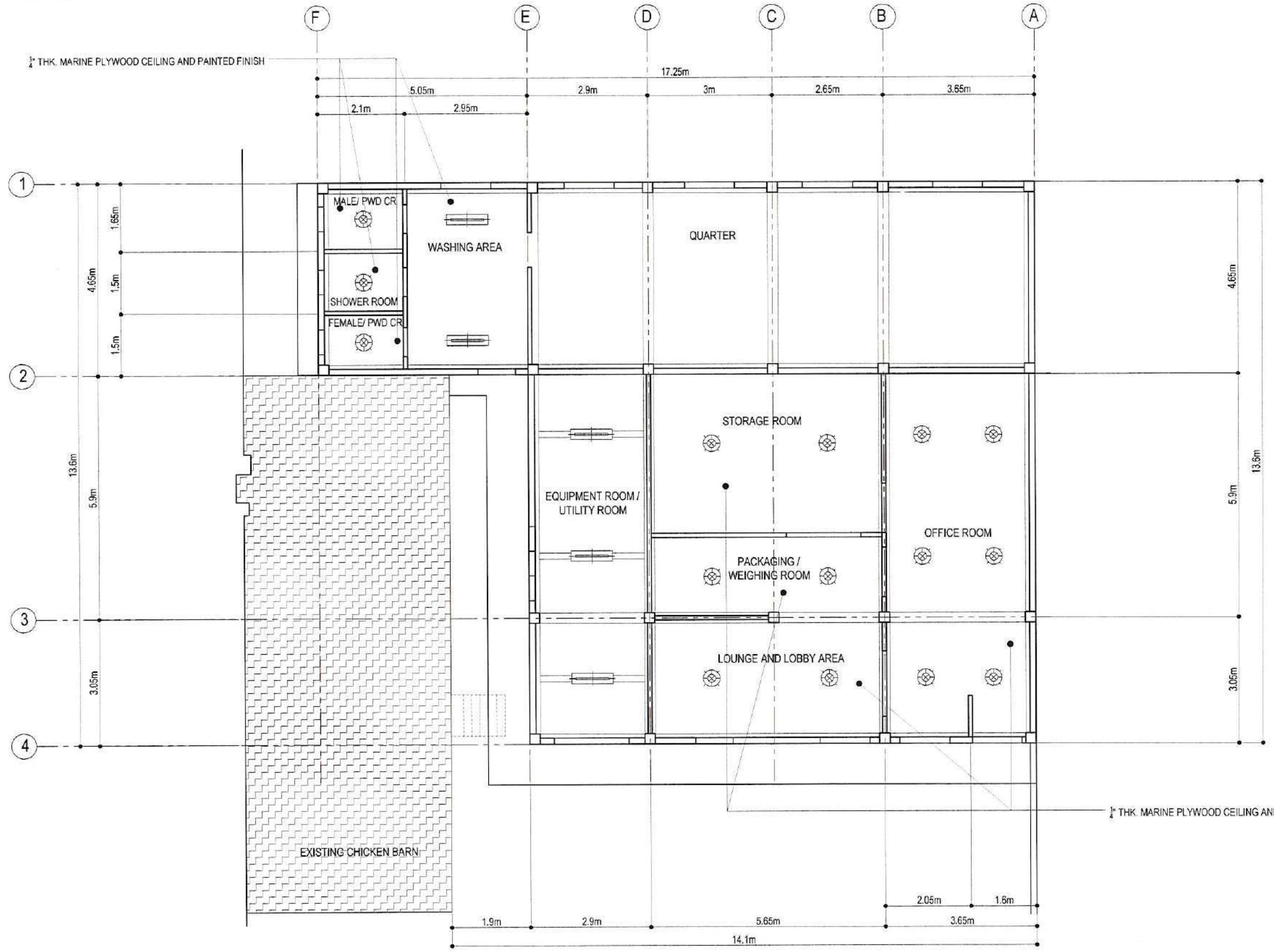
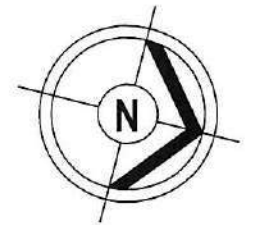

A REFLECTED CEILING PLAN
 SCALE 1:100 MTS.

 ARCH. HAZELINE N. TIBANGAY, UAP PRC REG. NO. 028540 - NOV. 18, 2024 PTR NO. - LA TRINIDAD - ARCHITECT	ENGINEER	DRAFTED BY: ERGD 2024	OWNER/ PROJECT TITLE/ LOCATION REPAIR OF THE POULTRY OFFICE BUILDING BSU LA TRINIDAD CAMPUS, BALILI, LA TRINIDAD, BENGUET	CONFORME: BERNARD B. BALAG JR. END-USERS	RECOMMENDING APPROVAL: ALLAN CASALDO SACPA SECTOR VICE PRESIDENT	APPROVED: FELIPE SALANG COMILA PRESIDENT	SHEET CONTENT: AS SHOWN	SHEET A 04-06

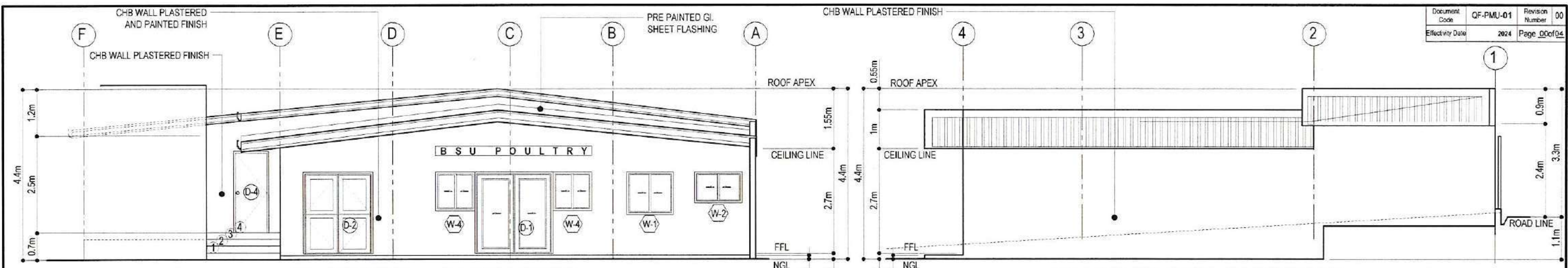

FRONT ELEVATION
 SCALE 1:100 MTS.

RIGHT SIDE ELEVATION
 SCALE 1:100 MTS.

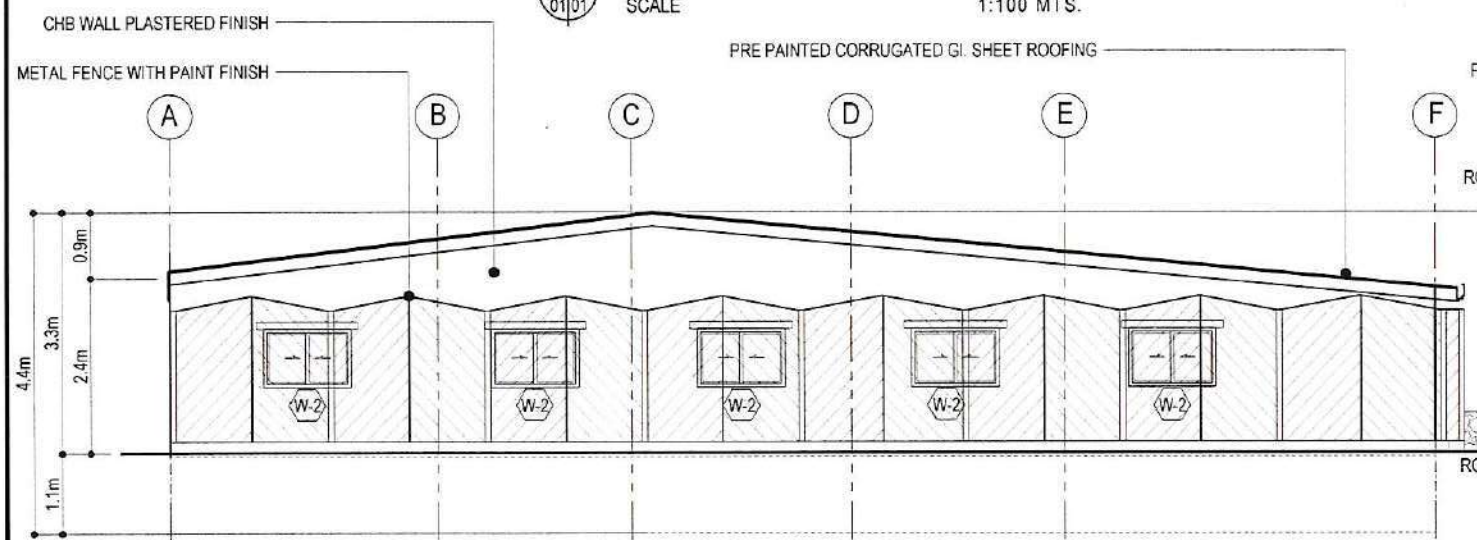

REAR ELEVATION
 SCALE 1:100 MTS.

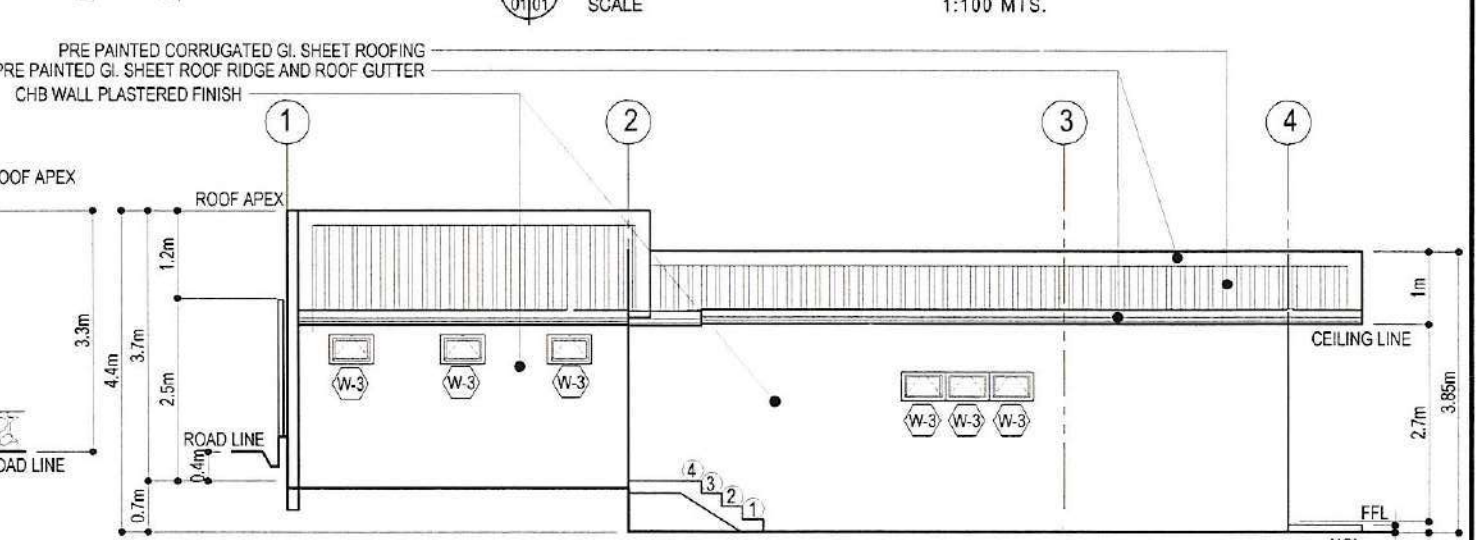

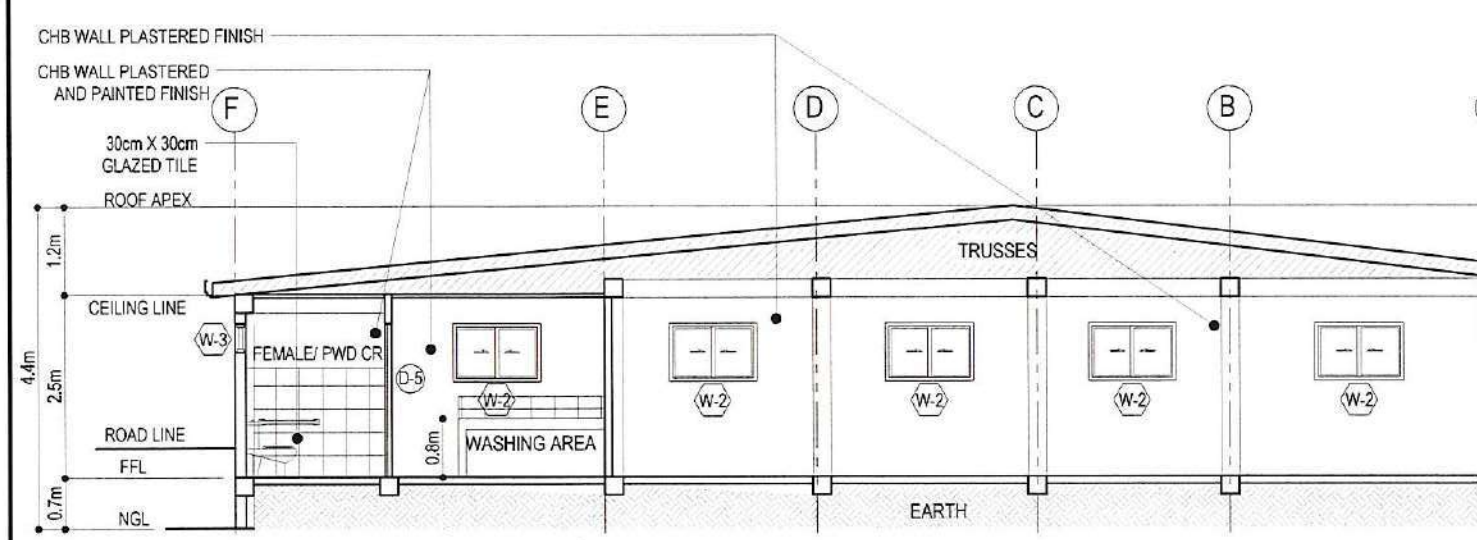

LEFT SIDE ELEVATION
 SCALE 1:100 MTS.

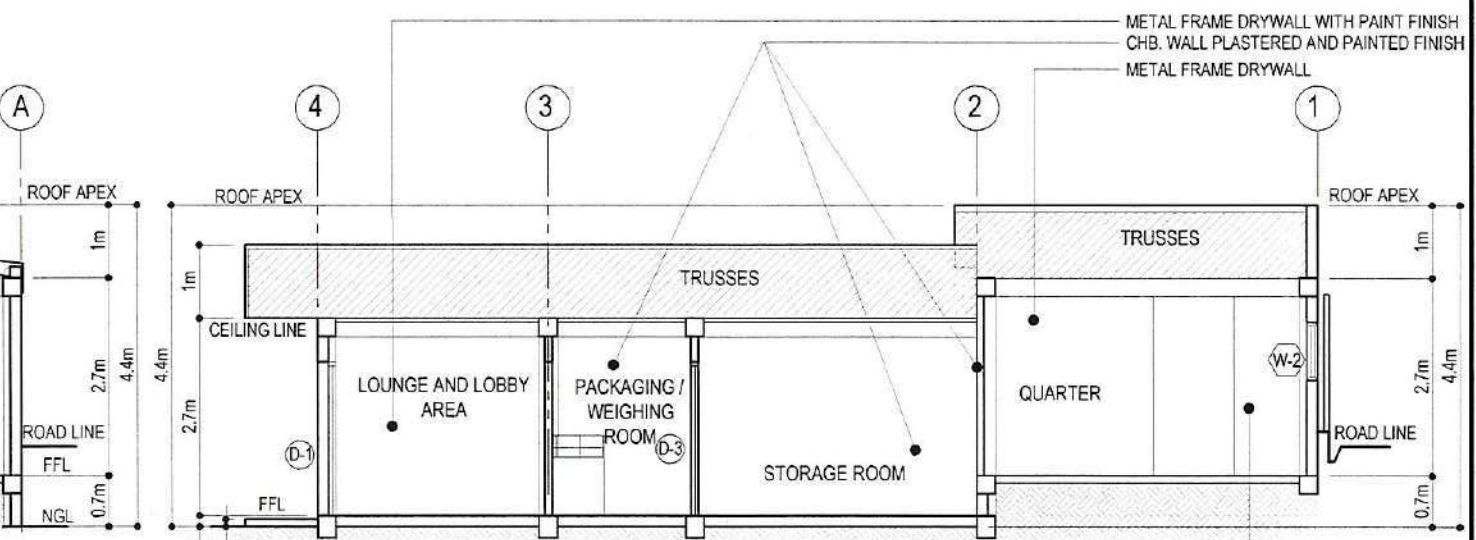

LONGITUDINAL SECTION
 SCALE 1:100 MTS.

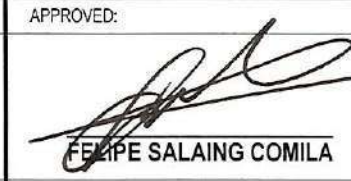

CROSS SECTION
 SCALE 1:100 MTS.

<p>ARCH. HAZEL N. TIBANGAY, UAP PRC REG. NO. 028540 - NOV. 18, 2024 PTR. NO. _____ - LA TRINIDAD - _____</p> <p>ARCHITECT</p>	<p>ENGINEER</p>	<p>DRAFTED BY: ERGD 2024</p> 	<p>OWNER/ PROJECT TITLE/ LOCATION</p> <p>REPAIR OF THE POULTRY OFFICE BUILDING BSU LA TRINIDAD CAMPUS, BALILI, LA TRINIDAD, BENGUET</p>	<p>CONFORME:</p> <p> BERNARD B. BALAG JR. END-USERS</p>	<p>RECOMMENDING APPROVAL:</p> <p> ALLAN CASALDO SACPA SECTOR VICE PRESIDENT</p>	<p>APPROVED:</p> <p> FEME SALAING COMILA PRESIDENT</p>	<p>SHEET CONTENT:</p> <p>AS SHOWN</p>	<p>SHEET</p> <p>A 05-06</p>
			<p>ARCHITECT: HAZEL N. TIBANGAY, UAP ENGINEER: [Signature] DRAFTED BY: ERGD 2024 OWNER: BSU LA TRINIDAD CAMPUS, BALILI, LA TRINIDAD, BENGUET CONFORME: BERNARD B. BALAG JR. (END-USERS) RECOMMENDING APPROVAL: ALLAN CASALDO SACPA (SECTOR VICE PRESIDENT) APPROVED: FEME SALAING COMILA (PRESIDENT) SHEET CONTENT: AS SHOWN SHEET: A 05-06</p>					

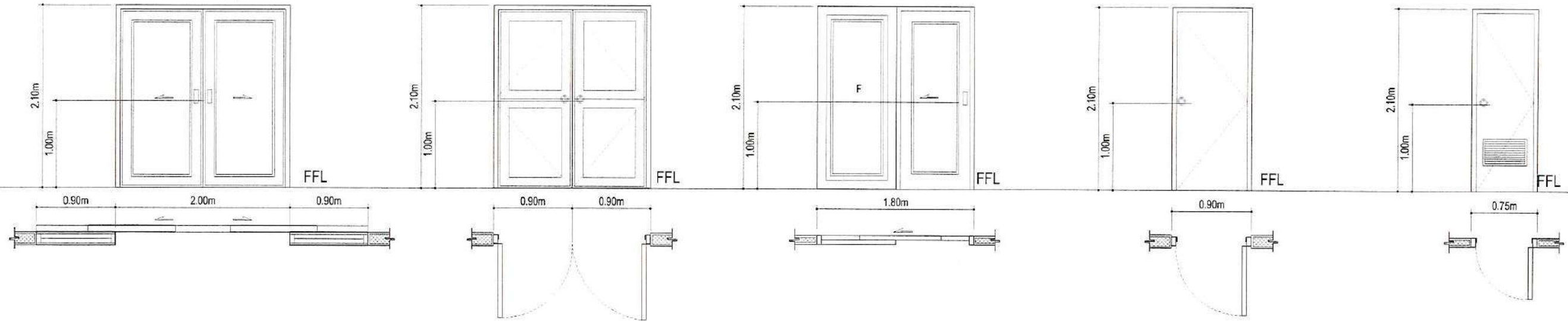

D-01	TYPE:	SLIDING DOUBLE DOOR ON A ALUMINUM FRAME AND SLIDING DOOR TRACK, WITH CLEAR GLASS VISION PANEL AND WITH COMPLETE HARDWARE AND ACCESSORIES.
1-SET/S	LOCATION:	LOUNGE AREA/ LOBBY

D-02	TYPE:	SWING DOUBLE DOOR ON A ALUMINUM FRAME WITH ALUMINUM DOOR JAMB AND WITH COMPLETE HARDWARE AND ACCESSORIES.
1-SET/S	LOCATION:	EQUIPMENT ROOM/ UTILITY ROOM

D-03	TYPE:	SLIDING DOOR ON A 40mm THK. ALUMINUM FRAME AND SLIDING DOOR TRACK, WITH CLEAR GLASS VISION PANEL AND WITH COMPLETE HARDWARE AND ACCESSORIES.
1-SET/S	LOCATION:	LOUNGE AREA/ LOBBY

D-04	TYPE:	SWING STEEL DOOR ON A STEEL DOOR JAMB AND WITH COMPLETE HARDWARE AND ACCESSORIES.
1-SET/S	LOCATION:	WASH AREA

D-05	TYPE:	SWING PVC DOOR ON A PVC DOOR JAMB WITH LOUVER AND WITH COMPLETE HARDWARE AND ACCESSORIES.
3-SET/S	LOCATION:	MALE PWD CR/ FEMALE PWD CR/ SHOWER

DOORS SCHEDULE
 SCALE: 1:50 MTS.

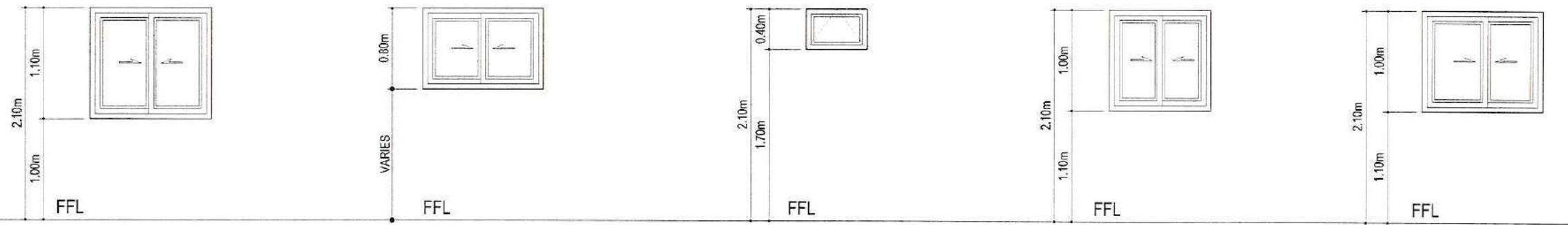

W1	TYPE:	8mm THK. CLEAR GLASS SLIDING WINDOW ON AN ALUMINUM WINDOW FRAME, WITH COMPLETE HARDWARE AND ACCESSORIES.
1-SET/S	LOCATION:	OFFICE ROOM

W2	TYPE:	8mm THK. CLEAR GLASS SLIDING WINDOW ON AN ALUMINUM WINDOW FRAME, WITH COMPLETE HARDWARE AND ACCESSORIES.
6-SET/S	LOCATION:	OFFICE ROOM/ QUARTERS/ WASH ROOM

W3	TYPE:	6mm THK. CLEAR GLASS AWNING WINDOW ON AN ALUMINUM WINDOW FRAME, WITH COMPLETE HARDWARE AND ACCESSORIES.
6-SET/S	LOCATION:	EQUIPMENT ROOM/ CR

W4	TYPE:	8mm THK. CLEAR GLASS SLIDING WINDOW ON AN ALUMINUM WINDOW FRAME, WITH COMPLETE HARDWARE AND ACCESSORIES.
2-SET/S	LOCATION:	LOUNGE AREA/ LOBBY

W5	TYPE:	8mm THK. CLEAR GLASS SLIDING WINDOW ON AN ALUMINUM WINDOW FRAME, WITH COMPLETE HARDWARE AND ACCESSORIES.
2-SET/S	LOCATION:	OFFICE ROOM/ WEIGHING ROOM

WINDOWS SCHEDULE
 SCALE: 1:50 MTS.

ARCH. HAZELINE N. TIBANGAY, UAP PRC REG. NO. 028540 - NOV.18, 2024 PTR NO. - LA TRINIDAD - ARCHITECT	ENGINEER	DRAFTED BY: ERGD 2024	OWNER/ PROJECT TITLE/ LOCATION	CONFORME:	RECOMMENDING APPROVAL:	APPROVED:	SHEET CONTENT:	SHEET
			REPAIR OF THE POULTRY OFFICE BUILDING BSU LA TRINIDAD CAMPUS, BALILI, LA TRINIDAD, BENGUET	BERNARD B. BALAG JR. END-USERS	ALLAN CASALDO SACPA SECTOR VICE PRESIDENT	FELIPE SALAING COMILA PRESIDENT	AS SHOWN	A 06-06

ELECTRICAL GENERAL NOTES:



1. ALL ELECTRICAL WORKS SHALL CONFORM TO THE LATEST EDITION OF PHILIPPINE ELECTRICAL CODE, TO THE RULES AND REGULATIONS OF LOCAL AND NATIONAL AUTHORITIES CONCERNED AND THE REQUIREMENTS OF LOCAL UTILITY COMPANIES.
2. WIRING METHODS SHALL BE AS FOLLOWS
 - a. MAIN SERVICE ENTRANCE RIGID STEEL CONDUIT (RSC)
 - b. RACEWAYS SURFACE MOUNTED IN CONCRETE WALL AND EMBEDDED IN CONCRETE FLOORING POLYVINYL CHLORIDE (PVC)
 - c. RACEWAYS NOT EMBEDDED IN CONCRETE ELECTRICAL METALLIC TUBING (EMT)
3. SERVICE VOLTAGE ENTERING THE STRUCTURE SHALL BE 230 VOLTS SINGLE PHASE TWO WIRE SYSTEM.
4. MINIMUM SIZE OF WIRE AND OF CONDUIT SHALL BE 2.0 mm Ø THHN (#14 AWG) AND 15mm (1/ 2") NOMINAL DIAMETER RESPECTIVELY, UNLESS OTHERWISE SPECIFIED ON PLANS.
5. NO BRANCH CIRCUIT WIRING IN LIGHTING AND POWER SHALL HAVE A LOAD MORE THAN 80% OF IT'S RATING.
6. ALL MATERIALS TO BE USED SHALL BE NEW AND APPROVED TYPE APPROPRIATE FOR BOTH LOCATION AND INTENDED USE.
7. UNLESS OTHERWISE SPECIFIED PULL BOXES OR JUNCTION BOXES SHALL BE PROVIDED WHENEVER REQUIRED AND NECESSARY, ALTHOUGH SUCH BOXES ARE NOT INDICATED ON PLANS.
8. FOR EACH SPARE CIRCUIT IN PANEL BOARD, PROVIDE AN EMPTY CONDUIT 20mm Ø (3/ 4") DIAMETER TERMINATING TO A COVERED SQUARE BOX.
9. ALL LOADS SHALL BE PROPERLY AND ADEQUATELY GROUNDED.
10. ALL MATERIALS AND EQUIPMENT TO BE USED SHALL BE BRAND NEW AND OF APPROVED TYPE AS LOCATION AND PURPOSE.
11. KITCHEN PLANS SHALL GOVERN ON THE ACTUAL LOCATION AND DIMENSION PRIOR TO ROUGH-IN OF CONDUIT AND PIPES.
12. ALL INSTALLATIONS AND WIRING SHALL BE CONCEALED FROM VIEW AND SHALL BE ENCASED IN POLYVINYL CHLORIDE (PVC) CONDUITS OR ELECTRICAL METALLIC TUBING (BMT) OR RIGID STEEL CONDUITS (RSC).
13. ALL JUNCTION BOXES, DISCONNECTS, ETC. SHALL BE INSTALLED SO AS NOT TO INTERFERE WITH EQUIPMENT PLACEMENTS.
14. ALL 20-AMPERES CIRCUIT HOMERUN TO PANEL BOARD MORE THAN 30 METERS IN LENGTH SHALL BE 5.5mm Ø THHN. (# 10), UNLESS OTHERWISE SPECIFIED ON PLANS.
15. LIGHT CONTROL SWITCHES SHALL BE RATED 10A 300V AND SHALL CARRY A LOAD GREATER THAN 50A.
16. AN EMPTY 3/ 4" DIA. RISER TERMINATING IN A 2" DEEP BY 4" OCTAGONAL BOX ABOVE CEILING SHALL BE PROVIDED TO ACCOMMODATE THE SPARE CIRCUIT IN PANEL BOARD.
17. ALL WORKS SHALL BE DONE WITH THE DIRECT SUPERVISION OF A DULY LICENSED ELECTRICAL ENGINEER OR A REGISTERED MASTER ELECTRICIAN.
18. NO ALTERATION SHALL BE DONE IN THE PLAN UNLESS NOTED BY THE DESIGNER AND OWNER.
19. OUTLET BOXES SHALL BE AS FOLLOWS:
 - A. LIGHT OUTLETS 1-1/ 2" DEEP BY 4" OCTAGONAL BOX WITH ONE OR TWO WAY ENTRIES
 - B. RECEPTACLES 2-1/ 8" DEEP 2"x4" UTILITY BOX ONE GANG WITH RAISED PLASTIC COVER
20. MOUNTING HEIGHTS SHALL BE AS FOLLOWS:
 - a. LIGHT SWITCHES.1370mm ABOVE FLOOR FINISH (A.F.F.)
 - b. RECEPTACLES. 300mm (A.F.F.)
 - c. COUNTER HEIGHT OUTLET.1300mm (A.F.F.)
 - d. TV/ TELEPHONE OUTLET. 300mm (A.F.F.)
 - e. DISCONNECT MAIN.1370mm (A.F.F.)
 - f. PANEL BOARDS. 1700mm (A.F.F.)
 - g. OTHERSREFER TO KITCHEN PLANS

ELECTRICAL LEGENDS:	
SYMBOL	DESCRIPTION
	LED TUBE LIGHTING
	20 WATTS – 25 WATTS LED PIN LIGHTING
	HOMERUN
	WIRE LINE
	SWITCH INDICATOR LINE
	PANEL BOX
	ELECTRICAL METER
	CIRCUIT BREAKER
	DUPLEX CONVENIENCE OUTLET
	SINGLE CONVENIENCE OUTLET
	SINGLE SWITCH
	GROUND
	SERVICE ENTRANCE

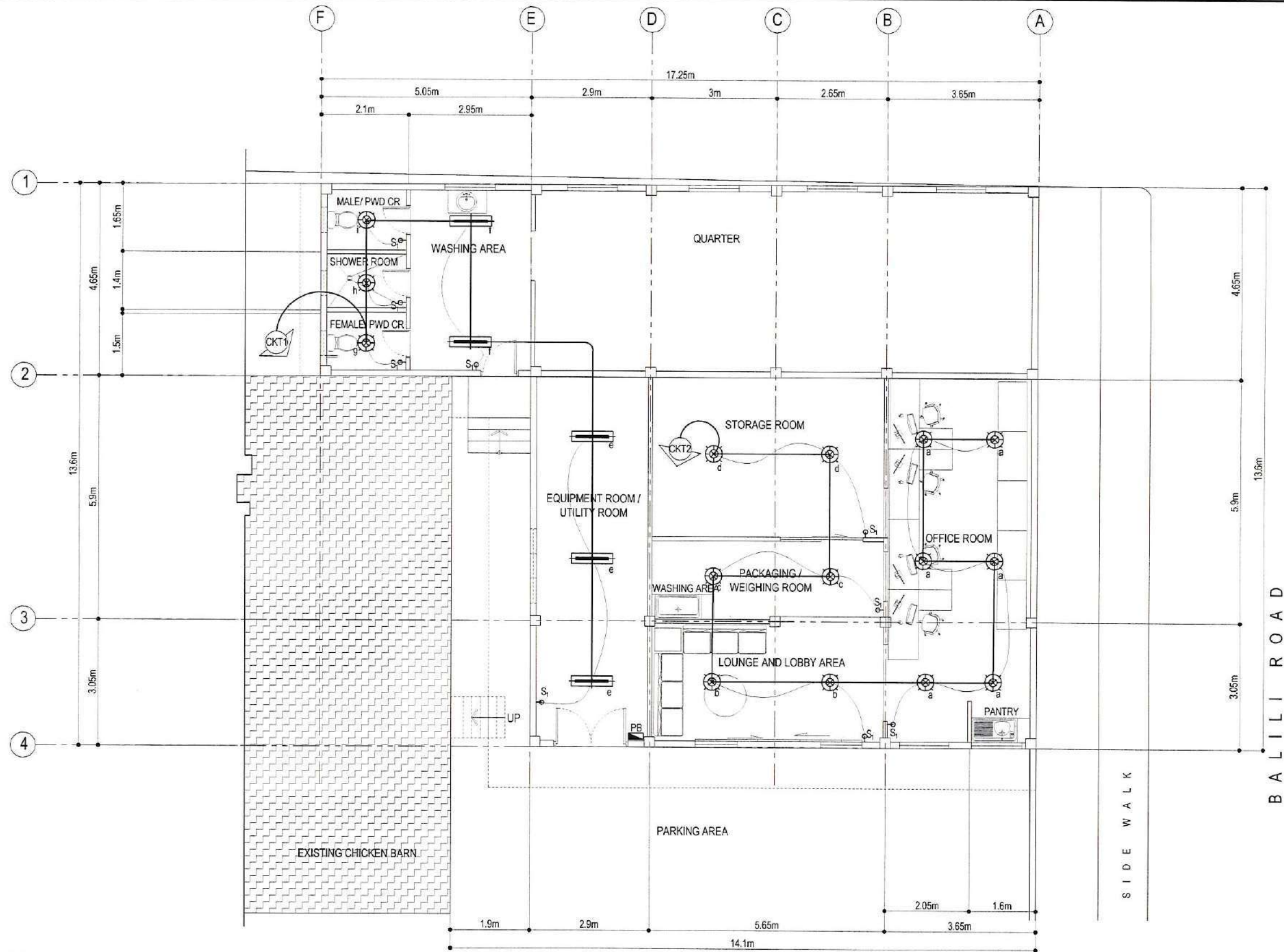
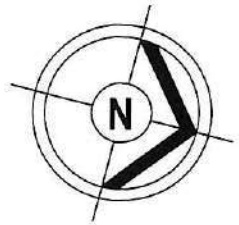
ARCH. HAZELINE N. TIBANGAY, UAP PRC REG. NO. 028540 - NOV.18, 2024 PTR NO. _____ - LA TRINIDAD - _____ ARCHITECT	ENGINEER	DRAFTED BY: ERGD 2024	OWNER/ PROJECT TITLE/ LOCATION REPAIR OF THE POULTRY OFFICE BUILDING BSU LA TRINIDAD CAMPUS, BALILI, LA TRINIDAD, BENGUET	CONFORME: BERNARD B. BALAG JR. END-USERS	RECOMMENDING APPROVAL: ALLAN CASALDO SACPA SECTOR VICE PRESIDENT	APPROVED: FELIPE SALAING COMILA PRESIDENT	SHEET CONTENT: AS SHOWN	SHEET E 01-04
			ARCHITECT	ENGINEER	END-USERS	SECTOR VICE PRESIDENT	PRESIDENT	AS SHOWN



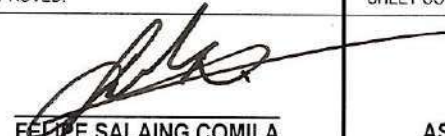
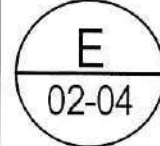

E LIGHTING OUTLET ELECTRICAL LAYOUT
 01/01 SCALE 1:100 MTS.

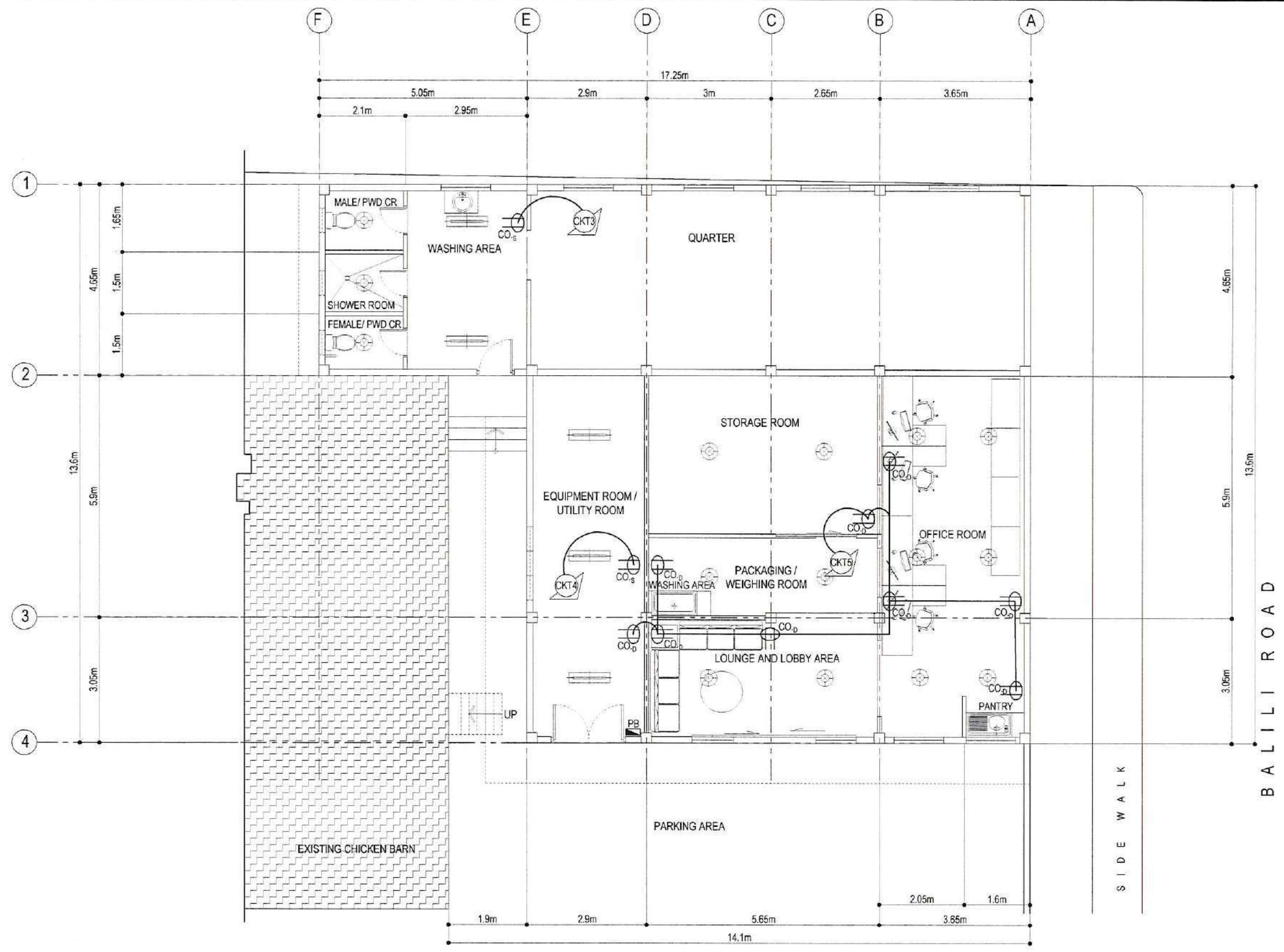
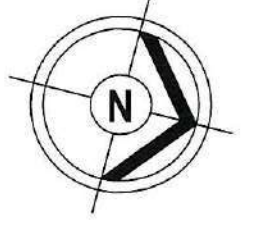
ARCH. HAZELINE N. TIBANGAY, UAP PRC REG. NO. 028540 - NOV.18, 2024 PTR NO. _____ - LA TRINIDAD - ARCHITECT	DRAFTED BY: ERGD 2024 ENGINEER	OWNER/ PROJECT TITLE/ LOCATION  REPAIR OF THE POULTRY OFFICE BUILDING BSU LA TRINIDAD CAMPUS, BALILI, LA TRINIDAD, BENGUET	CONFORME:  BERNARD B. BALAG JR. END-USERS	RECOMMENDING APPROVAL:  ALLAN CASALDO SACPA SECTOR VICE PRESIDENT	APPROVED:  FELIPE SALANG COMILA PRESIDENT	SHEET CONTENT: AS SHOWN	SHEET 
		ARCHITECT	ENGINEER	OWNER/ PROJECT TITLE/ LOCATION	CONFORME:	RECOMMENDING APPROVAL:	APPROVED:

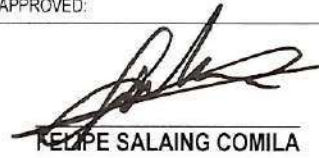

E CONVENIENCE OUTLET ELECTRICAL LAYOUT
 01/01 SCALE 1 : 1 0 0 M T S

<p>ARCH. HAZELINE N. TIBANGAY, UAP PRC REG. NO. 028540 - NOV.18, 2024 PTR NO. _____ - LA TRINIDAD - _____</p> <p>ARCHITECT</p>	<p>ENGINEER</p>	<p>DRAFTED BY: ERGD 2024</p> <p> OWNER/ PROJECT TITLE/ LOCATION</p> <p>REPAIR OF THE POULTRY OFFICE BUILDING BSU LA TRINIDAD CAMPUS, BALILI, LA TRINIDAD, BENGUET</p>	<p>CONFORME:</p> <p> BERNARD B. BALAG JR. END USERS</p>	<p>RECOMMENDING APPROVAL:</p> <p> ALLAN CASALDO SACPA SECTOR VICE PRESIDENT</p>	<p>APPROVED:</p> <p> FELIPE SALAING COMILA PRESIDENT</p>	<p>SHEET CONTENT:</p> <p>AS SHOWN</p>	<p>SHEET</p> <p>E 03-04</p>
--	-----------------	---	---	---	--	---------------------------------------	---

P A N E L B O A R D L O A D T A B U L A T I O N															
CKT. NO.	DESCRIPTION	QTY.					VOLTS	WATTS	VA	AMPERE	TRIP BEAKER	P	KAIC	WIRE SIZE	CONDUIT SIZE
		L.O.	C.O.	S ₁	S ₂	S ₃									
CKT. 01	6" DIA. LED PIN LIGHTING, 25W; T8 LED TUBE LIGHTING, 36W	8		5			230V	25-36	255 W	1.109 AMP	15 AT	2	10	2-2.0mm ² THHN	15mm Ø Conduit PVC
CKT. 02	6" DIA. LED PIN LIGHTING, 25W	12		4			230V	25	300 W	1.304 AMP	15 AT	2	10	2-2.0mm ² THHN	15mm Ø Conduit PVC
CKT. 03	SINGLE CONVENIENCE OUTLET		1				230V	1000	1000 W	4.348 AMP	20 AT	2	10	2-3.5mm ² THHN	15mm Ø Conduit PVC
CKT. 04	SINGLE CONVENIENCE OUTLET		1				230V	1000	1000 W	4.696 AMP	20 AT	2	10	2-3.5mm ² THHN	15mm Ø Conduit PVC
CKT. 05	DUPLEX CONVENIENCE OUTLET		9				230V	180	1620 W	7.043 AMP	20 AT	2	10	2-3.5mm ² THHN	15mm Ø Conduit PVC
CKT. 06	SPARE						230V	1000	1000 W	4.348 AMP	20 AT	2	10	2-3.5mm ² THHN	15mm Ø Conduit PVC
TOTAL		20	11	9					5175 W	22.848 AMP	30 AT			2-5.5 mm ² THHN	20mm Ø Conduit PVC

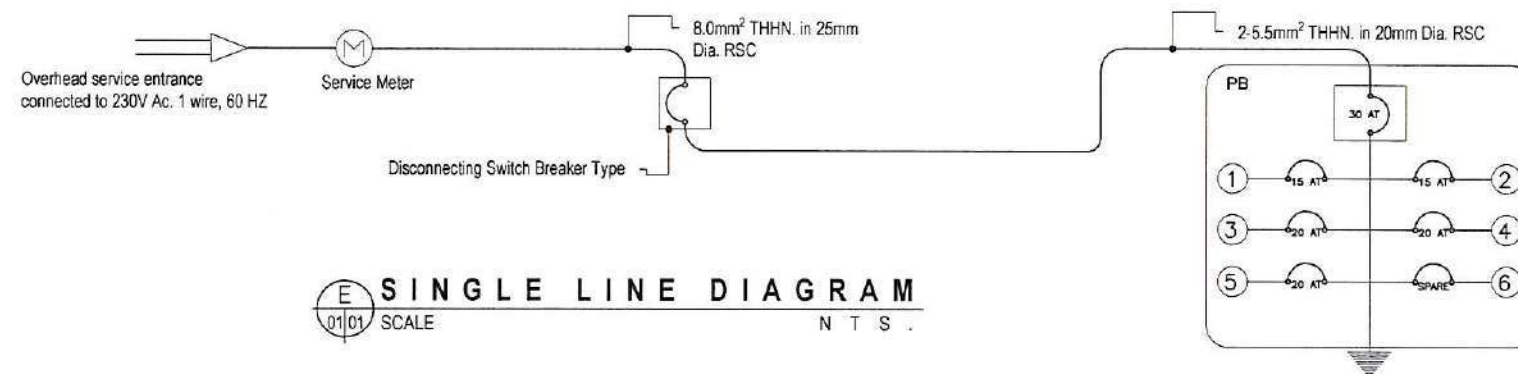
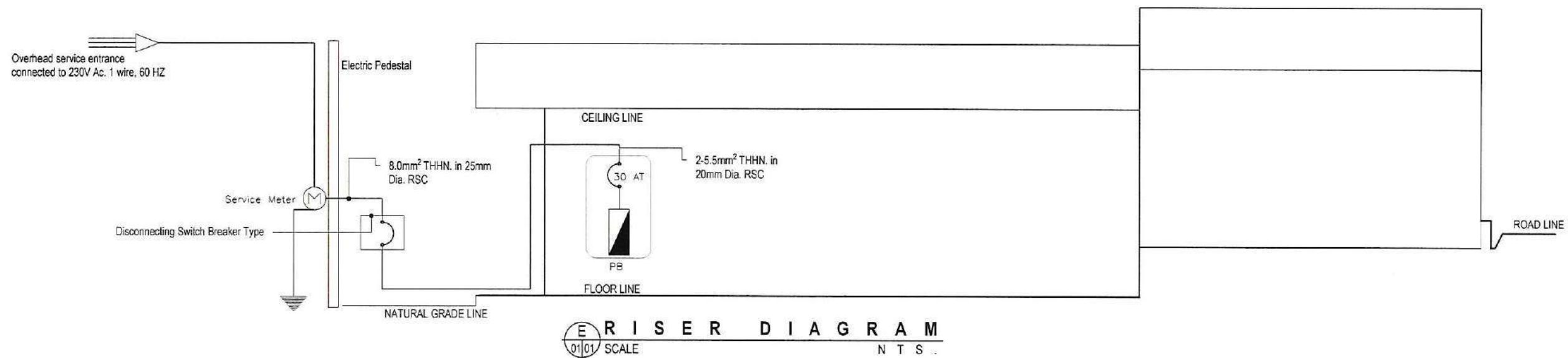





LOAD COMPUTATION:

TOTAL CONNECTED LOAD= 5175 VA
 $I_{TOTAL} = 80\% \text{ DEMAND FACTOR, AS PERMITTED BY THE NATIONAL ELECTRICAL CODE}$

$\frac{5175 \times 80\%}{230 \text{ VOLTS}} = 18 \text{ AMP.}$

USE: 30 AT, 2P, 230V, 10 KAIC FOR MAIN SERVICE PROTECTION
 SUB-FEEDER AND PROTECTION USE: 8.0mm² or NO. 8 THW. COOPER WIRE
 PVC CONDUIT PIPE USE 25mm Dia. PIPE

$I_{TOTAL} = \frac{18 \times 230V}{1000} \times 120\% = 4.97 \text{ KVA}$

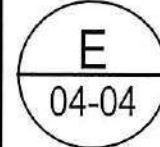
ARCH. HAZELINE N. TIBANGAY, UAP PRC REG. NO. 028540 - NOV.18, 2024 PTR NO. _____ - LA TRINIDAD - _____ ARCHITECT	ENGINEER	DRAFTED BY: ERGD 2024	OWNER/ PROJECT TITLE/ LOCATION  REPAIR OF THE POULTRY OFFICE BUILDING BSU LA TRINIDAD CAMPUS, BALILI, LA TRINIDAD, BENGUET	CONFORME:  BERNARD B. BALAG JR. END-USERS	RECOMMENDING APPROVAL:  ALLAN CASALDO SACPA SECTOR VICE PRESIDENT	APPROVED:  FELIPE SALAING COMILA PRESIDENT	SHEET CONTENT: AS SHOWN	SHEET 
			ARCHITECT	ENGINEER	ARCHITECT	END-USERS	SECTOR VICE PRESIDENT	PRESIDENT

GENERAL NOTES:

- ALL PLUMBING WORKS TO BE DONE AND SIZES OF PIPES TO BE USED SHALL BE IN ACCORDANCE WITH THE LATEST EDITION OF THE NATIONAL PLUMBING CODE OF THE PHILIPPINES AND LOCAL REGULATIONS AND ORDINANCES.
- ALL PIPES SHALL BE INSTALLED AS INDICATED IN THE WORKING DRAWINGS. ANY RELOCATION REQUIRED FOR PROPER EXECUTION OF OTHER TRADES SHALL BE UPON THE APPROVAL OF THE SANITARY ENGINEER.
- WRITTEN DIMENSIONS SHALL TAKE PRECEDENCE OVER SCALED DIMENSIONS.
- ALL PIPES SHALL BE PROVIDED W/ PROPER HANGER AND SUPPORT.
- ALL FIXTURES SHALL BE VENTED INDIVIDUALLY AND WATERLINES SHALL BE VALVE BY GROUP.
- UNLESS OTHERWISE SPECIFIED, ALL PLUMBING FIXTURES SHALL BE PROPERLY VENTED. MAXIMUM DISTANCE OF VENTILATION FROM FIXTURES SHALL BE 1.50m MEASURED ALONG THE LENGTH OF PIPE.
- ALL PLUMBING FITTINGS SHALL BE ACCESSIBLE FOR MAINTENANCE. PROVIDE MANHOLE IF SUCH INSTALLATIONS ARE INSIDE THE CEILING.
- ALL CHANGES IN DIRECTION SHALL BE MADE BY APPROPRIATE USE OF FORTY-FIVE DEGREES (45') WYES, LONG SWEEP QUARTER BEND, ONE EIGHT WHEN THE CHANGE OF FLOW IS FROM HORIZONTAL TO VERTICAL A SINGLE BEND COMBINATION MAY BE USED ONLY ON VENT PIPE.
- NO DOUBLE HUB OR DOUBLE TEE BRANCH SHALL BE USED ON HORIZONTAL SOIL OR WASTE LINES.
- PROVIDE PIPE SLEEVES AT WALL, COLUMNS OR SLAB TO PROTECT FROM BREAKAGE.
- ALL EXPOSED PIPINGS AND FITTINGS IN THE AREAS SHALL BE CHROME PLATED.
- THE BRAND AND OTHER DETAILED PLUMBING FIXTURES SHALL BE IN ACCORDANCE WITH THE SCHEDULE FURNISHED BY THE ARCHITECT.
- GATE VALVE SHALL BE BRONZE BODY, SOLID WEDGE TYPE, SCREWED OR FLANGE END.
- USE POLYPROPYLENE RANDOM, TYPE 3, PN20 FOR ALL WATER PIPING SYSTEM.
- USE UPVC SANITARY PIPING SYSTEM SERIES 1000 FOR 100 Ø AND SMALLER AND GRAVITY SEWER MAIN UPVC PIPING SYSTEM FOR 150 Ø AND BIGGER.
- ENGINEER-IN-CHARGE TO VERIFY ACTUAL LOCATION AND ELEVATION OF STREET DRAINAGE, STREET SEWER AND STREET WATER MAINS FOR CONNECTION BEFORE CONSTRUCTION.

MATERIAL SPECIFICATIONS

- COLD WATER LINE (FOR INTERIOR PIPES)** - POLYPROPYLENE BY VESBO, UNITEC, WIRSBO & REHAU, OR APPROVED EQUIVALENT.
- VENT & DOWNSPOUT** - 50 TO 150mm. Ø SHALL BE POLYVINYL CHLORIDE (PVC) PIPE SERIES 1000. (FOR EXTERIOR AND EXPOSED PIPES) PNS/SAO 374. MANUFACTURED ACCORDING TO ASTM 2729.
- DRAINAGE LINE** - 50 TO 160mm. Ø SHALL BE POLYVINYL CHLORIDE (PVC) PIPE, SERIES 1000. MANUFACTURED ACCORDING TO ASTM 2729.
 - 300mm. Ø LARGER SHALL BE REINFORCED CONCRETE PIPE, CONFORMING TO ASTM-76 & NON-REINFORCED CONCRETE PIPE 200mm. TO 350mm. Ø TO ASTM-C14.
- SEWER LINE** - 50 TO 160mm. Ø SHALL BE POLYVINYL CHLORIDE (PVC) PIPE, SDR-35 MANUFACTURED ACCORDING TO ASTM 3034.
- PIPE DIAMETER** - ALL PIPE DIAMETERS INDICATED IN THE DRAWINGS ARE INSIDE DIAMETERS.

PLUMBING LEGENDS



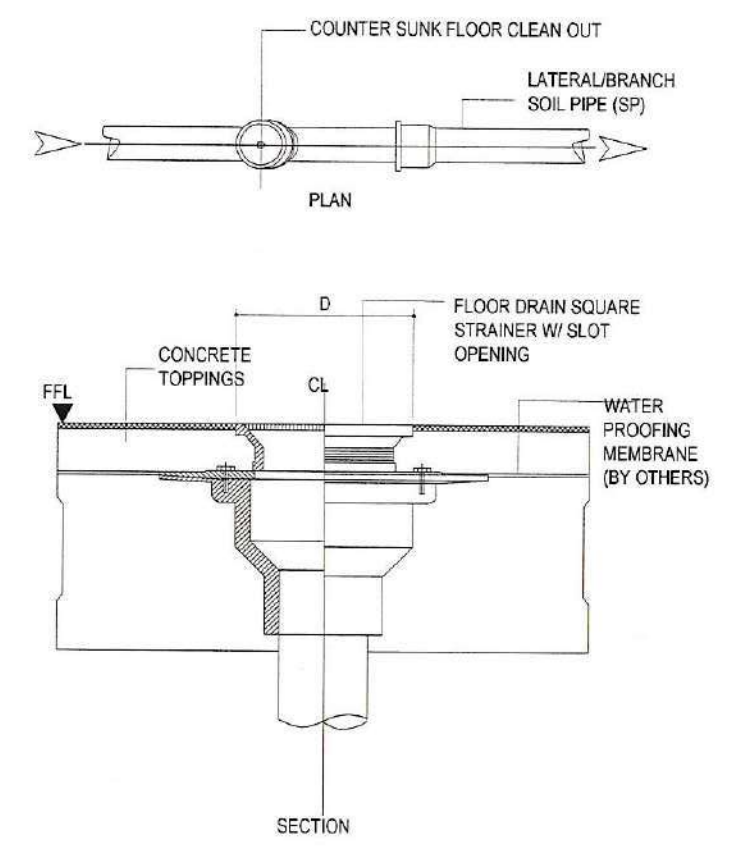
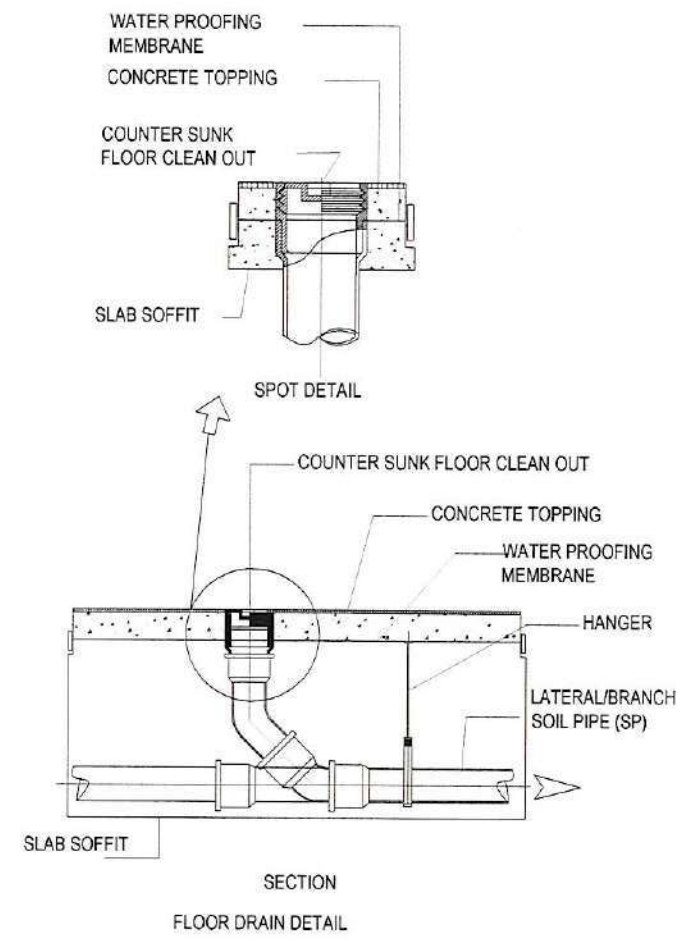
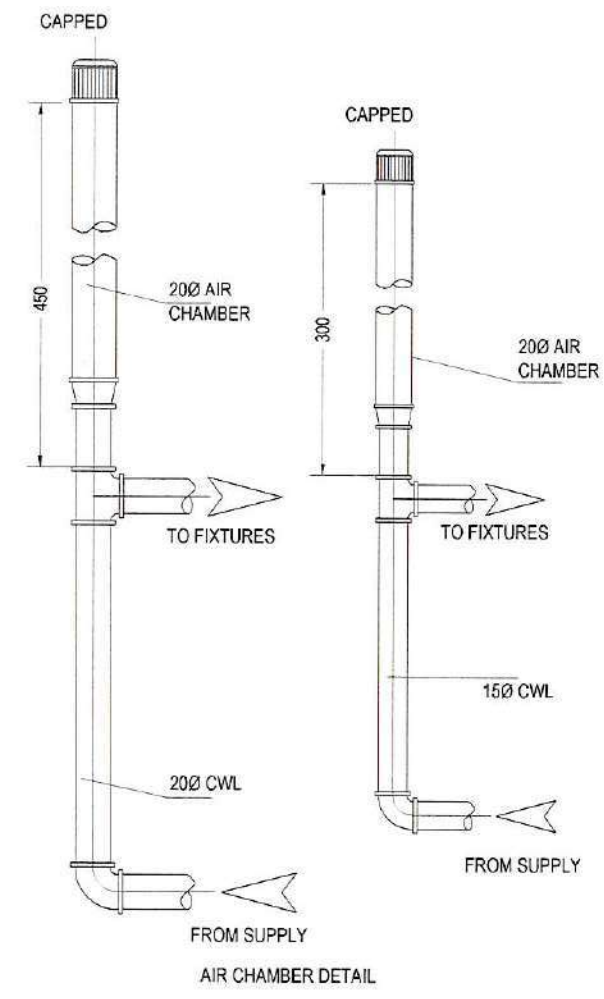

SYMBOLS	DESCRIPTION	SYMBOLS	DESCRIPTION
	GATE VALVE		FLOOR DRAIN
	URINAL		LAVATORY
	FLOW DIRECTION		WATER CLOSET
	WYE TEE PIPE		SINK
	ANGLE FITTING PIPE		STACK VENT
	P-TRAP PIPE		PIPE CLEAN-OUT
	DOWNSPOUT		WATER TAP

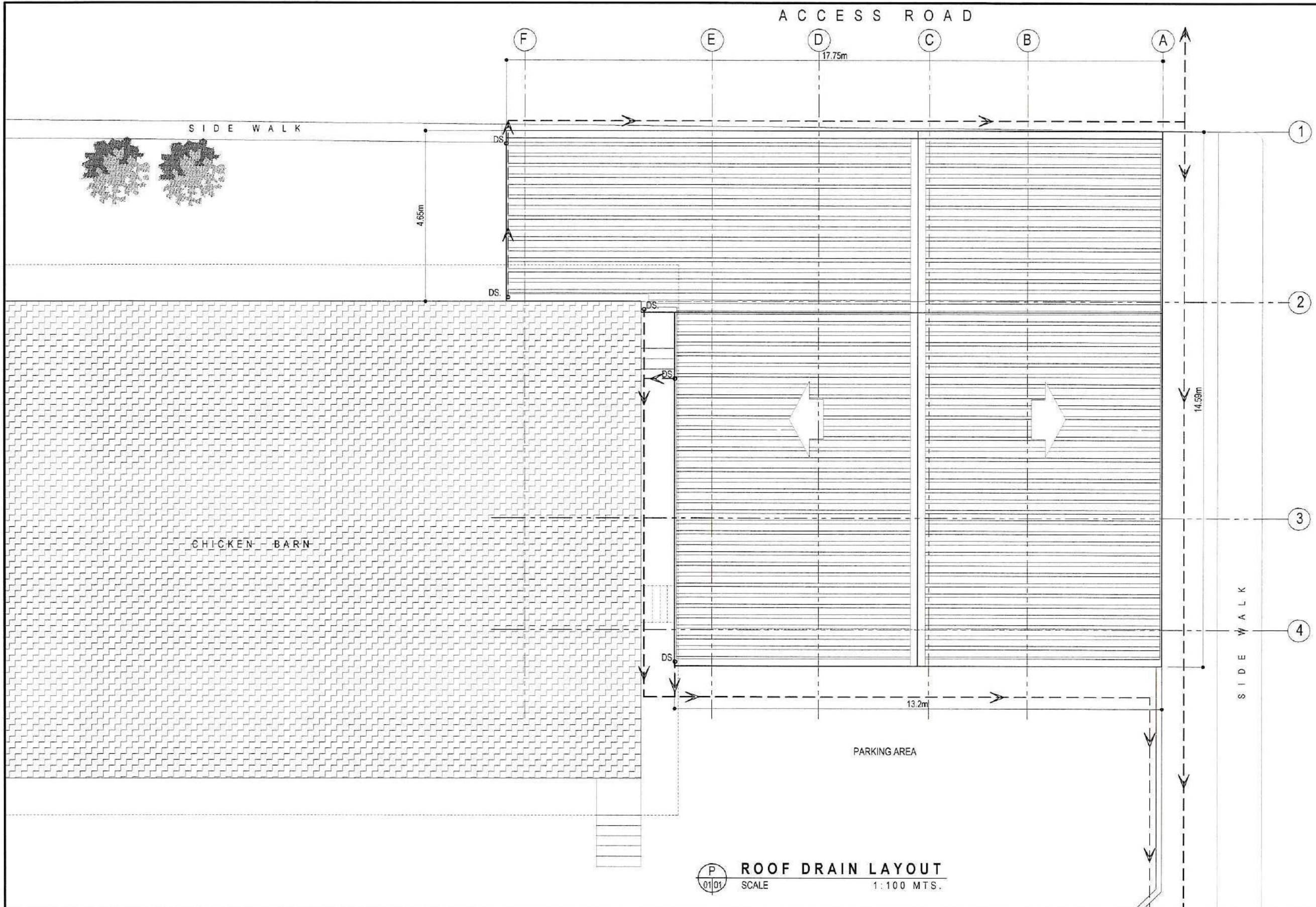
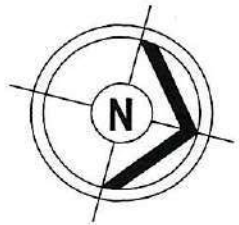

ARCH. HAZELINE N. TIBANGAY, UAP PRC REG. NO. 028540 - NOV. 18, 2024 PTR NO. LA TRINIDAD ARCHITECT	ENGINEER	ERGD 2024 OWNER/ PROJECT TITLE/ LOCATION REPAIR OF THE POULTRY OFFICE BUILDING BSU LA TRINIDAD CAMPUS, BALILI, LA TRINIDAD, BENGUET	CONFORME: BERNARD B. BALAG JR. END-USER	RECOMMENDING APPROVAL: ALLAN CASALDO SACPA SECTOR VICE PRESIDENT	APPROVED: FELIPE SALAING COMILA PRESIDENT	SHEET CONTENT: AS SHOWN	SHEET P 01-05





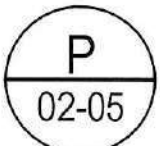

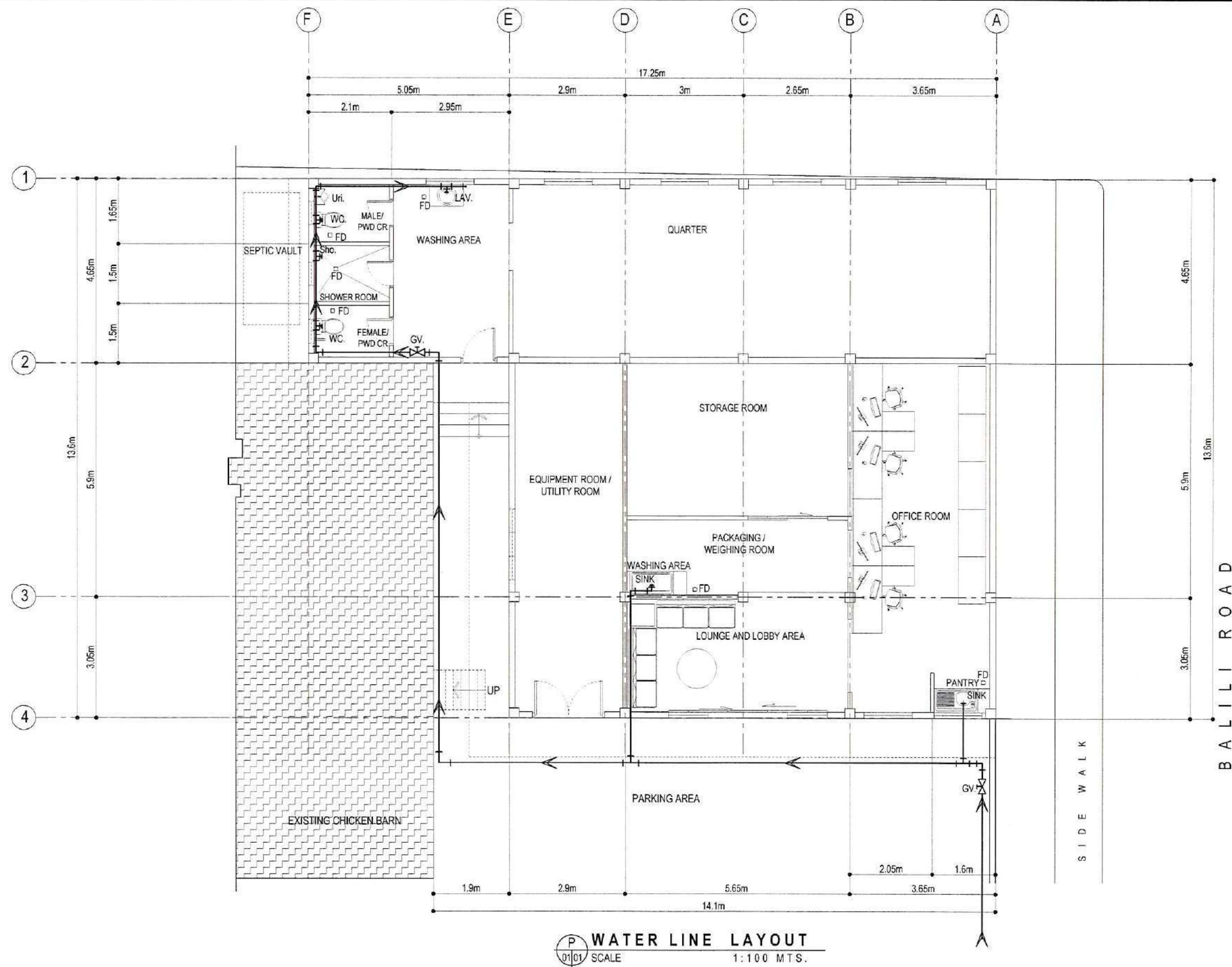
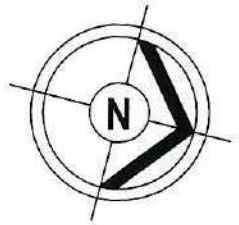
P
01/01 **ROOF DRAIN LAYOUT**
SCALE 1:100 MTS.

ARCH. HAZELINE N. TIBANGAY, UAP PRC REG. NO. 028540 - NOV.18, 2024 PTR NO. _____ - LA TRINIDAD _____ ARCHITECT	DRAFTED BY: ERGD 2024	OWNER/ PROJECT TITLE/ LOCATION  REPAIR OF THE POULTRY OFFICE BUILDING BSU LA TRINIDAD CAMPUS, BALILI, LA TRINIDAD, BENGUET	CONFORME:  BERNARD B. BALAG JR. END-USERS	RECOMMENDING APPROVAL:  ALLAN CASALDO SACPA SECTOR VICE PRESIDENT	APPROVED:  FELVIE SALAING COMILA PRESIDENT	SHEET CONTENT: AS SHOWN	SHEET 
		ARCHITECT	ENGINEER	ARCHITECT	ARCHITECT	ARCHITECT	ARCHITECT





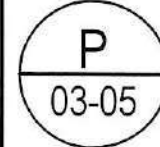

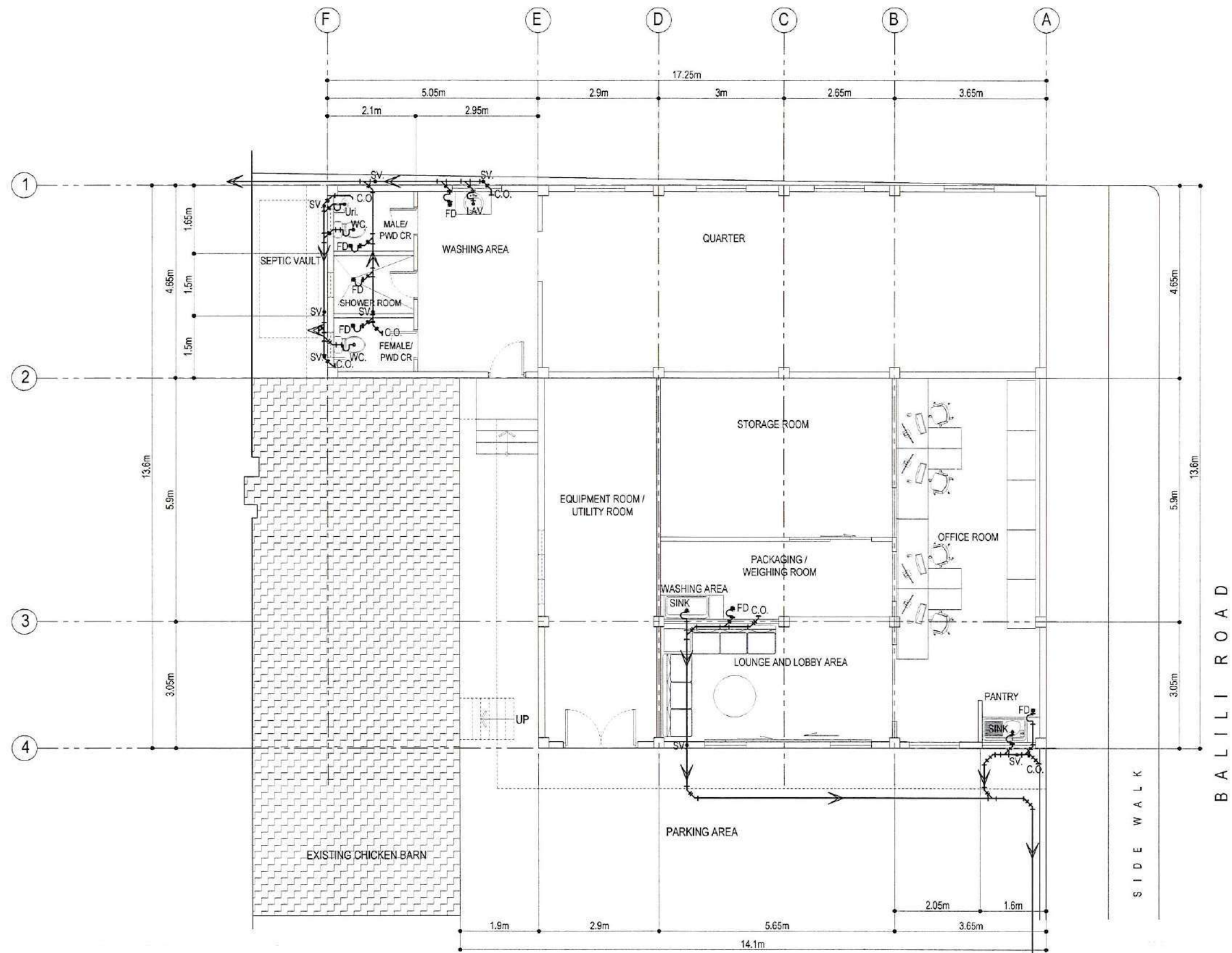
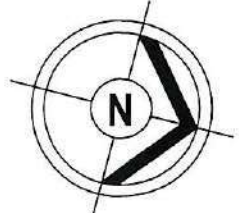
P WATER LINE LAYOUT
 01/01 SCALE 1:100 MTS.

ARCH. HAZELINE N. TIBANGAY, UAP PRC REG. NO. 028540 - NOV. 18, 2024 PTR. NO. - LA TRINIDAD - ARCHITECT	ENGINEER	DRAFTED BY: ERGD 2024	OWNER/ PROJECT TITLE/ LOCATION  REPAIR OF THE POULTRY OFFICE BUILDING BSU LA TRINIDAD CAMPUS, BALILI, LA TRINIDAD, BENGUET	CONFORME:  BERNARD B. BALAG JR. END-USER	RECOMMENDING APPROVAL:  ALLAN CASALDO SACPA SECTOR VICE PRESIDENT	APPROVED:  FELIPE SALAING COMILA PRESIDENT	SHEET CONTENT: AS SHOWN	SHEET 
			ARCHITECT	ENGINEER	ARCHITECT	END-USER	SECTOR VICE PRESIDENT	PRESIDENT





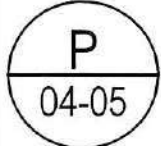

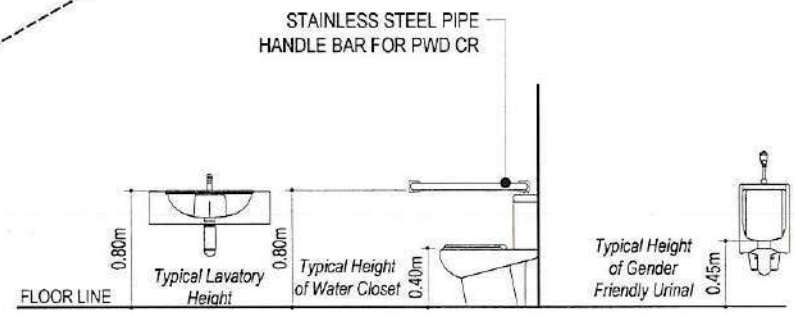
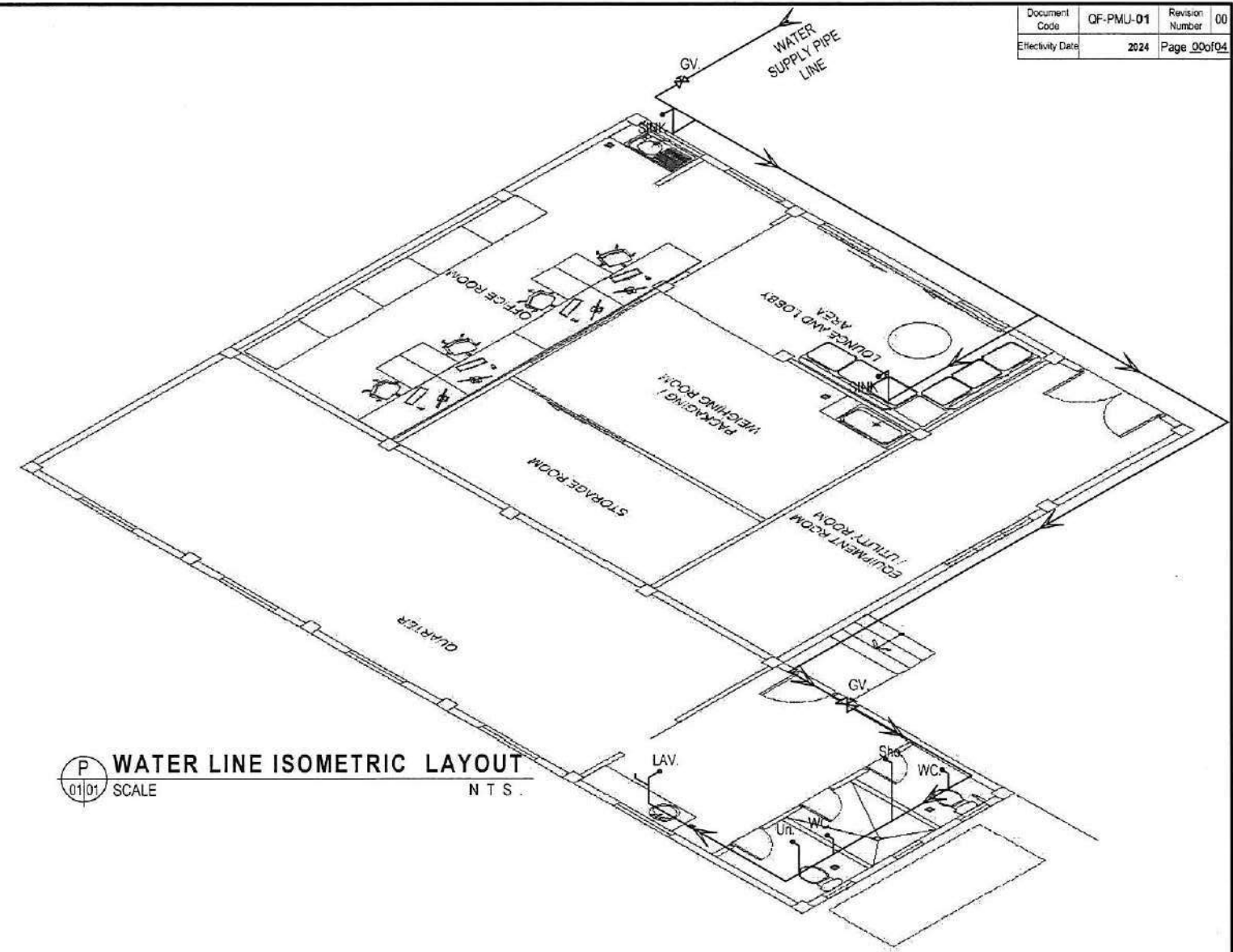
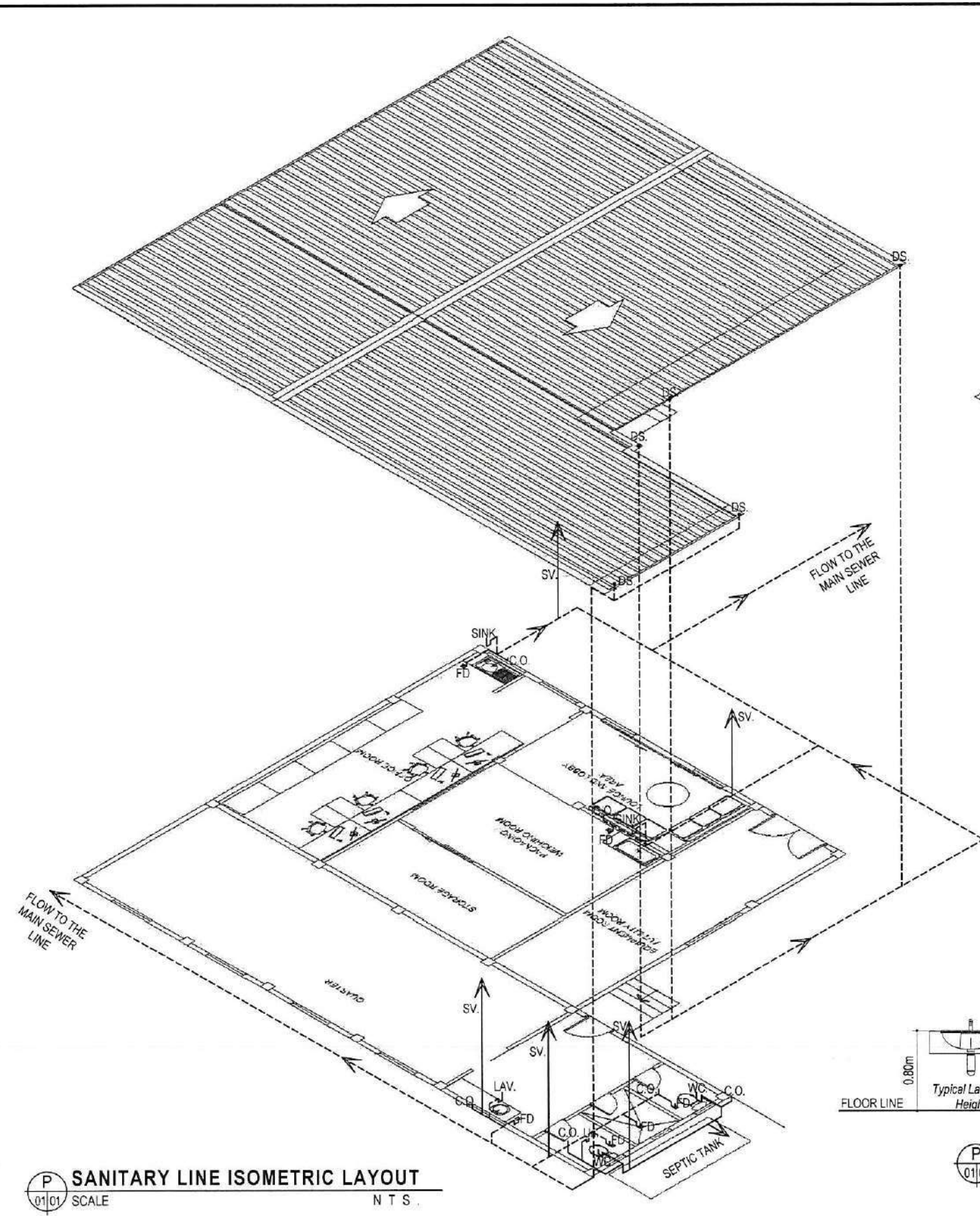
P SANITARY LINE LAYOUT
 SCALE 1:100 MTS.

ARCH. HAZELINE N. TIBANGAY, UAP PRC REG. NO. 028540 - NOV. 18, 2024 PTR. NO. - LA TRINIDAD - ARCHITECT	ENGINEER	DRAFTED BY: ERGD 2024  REPAIR OF THE POULTRY OFFICE BUILDING BSU LA TRINIDAD CAMPUS, BALILI, LA TRINIDAD, BENGUET	OWNER/ PROJECT TITLE/ LOCATION	CONFORME:  BERNARD B. BALAG JR. END-USERS	RECOMMENDING APPROVAL:  ALLAN CASALDO SACPA SECTOR VICE PRESIDENT	APPROVED:  FELIPE SALAING COMILA PRESIDENT	SHEET CONTENT: AS SHOWN	SHEET 
			ARCHITECT	ENGINEER	DRAFTED BY: ERGD 2024	OWNER/ PROJECT TITLE/ LOCATION	CONFORME: BERNARD B. BALAG JR. END-USERS	RECOMMENDING APPROVAL: ALLAN CASALDO SACPA SECTOR VICE PRESIDENT



P 01|01 SCALE 1:50 M T S .
FIXTURES HEIGHT DIMENSION

PLUMBING ANALYSIS			
FIXTURES	QTY.	EQUIVALENT FIXTURE UNIT	TOTAL FIXTURE UNIT
1. LAVATORY	1	1	1 FIXTURE UNIT
2. WATER CLOSET	2	6	12 FIXTURE UNIT
3. URINAL	1	2	2 FIXTURE UNIT
3. FLOOR DRAIN	6	2	12 FIXTURE UNIT
4. SINK	2	2	4 FIXTURE UNIT
TOTAL = 31 FIXTURE UNIT			
IN THE PRESENCE OF WATER CLOSET USE MINIMUM SIZE OF DISCHARGE PIPE = 75mm DIA. RECOMMENDED SOIL PIPE SIZE = 101mm DIA. MINIMUM PIPE SIZE FOR FLOOR DRAIN DISCHARGE PIPE SIZE = 75mm DIA. USE MINIMUM VENT PIPE SIZE = 50 MM DIA.			

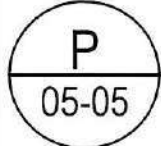
ARCH. HAZELINE N. TIBANGAY, UAP PRC REG. NO. 026540 - NOV.18, 2024 PTR. NO. _____ - LA TRINIDAD - _____ ARCHITECT	ENGINEER	DRAFTED BY: ERGD 2024	OWNER/ PROJECT TITLE/ LOCATION  REPAIR OF THE POULTRY OFFICE BUILDING BSU LA TRINIDAD CAMPUS, BALILI, LA TRINIDAD, BENGUET	CONFORME:  BERNARD B. BALAG JR. END-USERS	RECOMMENDING APPROVAL:  ALLAN CASALDO SACPA SECTOR VICE PRESIDENT	APPROVED:  FELIPE SALAING COMILA PRESIDENT	SHEET CONTENT: AS SHOWN	SHEET 
			ARCHITECT	ENGINEER	ARCHITECT	END-USERS	SECTOR VICE PRESIDENT	PRESIDENT

GENERAL CONSTRUCTION NOTES

GENERAL NOTES

1. IN THE INTERPRETATION OF THE DRAWING, INDICATED DIMENSIONS SHALL GOVERN AND DISTANCES AND SIZES SHALL NOT BE SCALED FOR CONSTRUCTION PURPOSES.
2. IN REFERENCE TO THE OTHER DRAWINGS, SEE ARCHITECTURAL DRAWINGS FOR DEPRESSIONS IN FLOOR SLABS, OPENING IN THE WALLS AND SLABS, INTERIOR PARTITIONS, LOCATION OF DRAINS, ETC.
3. IN CASE OF DISCREPANCIES AS TO THE LAYOUT, DIMENSIONS, AND ELEVATIONS BETWEEN THE STRUCTURAL PLANS, AND ARCHITECTURAL DRAWINGS, THE CONTRACTOR SHALL NOTIFY BOTH THE STRUCTURAL ENGINEER AND ARCHITECT.
4. ALL CONCRETE WORK SHALL BE DONE IN ACCORDANCE WITH THE ACI 318-95 BUILDING CODE REQUIREMENTS FOR REINFORCED CONCRETE AND ALL STRUCTURAL STEEL WORK ACCORDING WITH AISC SPECIFICATION (9th EDITION) IN SO FAR AS THEY DO NOT CONFLICT WITH THE LOCAL BUILDING CODE REQUIREMENT.
5. ACI REFERS TO AMERICAN CONCRETE INSTITUTE, AISC TO AMERICAN INSTITUTE OF STEEL CONSTRUCTION, AND ASTM TO AMERICAN SOCIETY FOR TESTING MATERIALS.
6. CONSTRUCTION NOTES AND TYPICAL DETAILS APPLY TO ALL DRAWINGS UNLESS OTHERWISE SHOWN OR NOTED. MODIFY TYPICAL DETAILS AS DIRECTED TO MEET SPECIAL CONDITIONS.
7. SHOP DRAWINGS WITH ERECTION AND PLACING DIAGRAMS OF ALL STRUCTURAL STEELS, MISCELLANEOUS IRON, PRE-CAST CONCRETE, ETC. SHALL BE SUBMITTED FOR ENGINEERS APPROVAL BEFORE FABRICATION.
8. CONTRACTOR SHALL NOTE AND PROVIDE ALL MISCELLANEOUS CURBS, SILLS, STOOLS, EQUIPMENT'S AND MECHANICAL BASES THAT ARE REQUIRED BY THE ARCHITECTURAL, ELECTRICAL, AND MECHANICAL DRAWINGS.
9. ALL RESULTS OF MATERIAL TESTING FOR CONCRETE, REINFORCING BARS, AND STRUCTURAL STEEL MUST BE NOTED AND APPROVED BY THE STRUCTURAL DESIGNER.

NOTES ON CONCRETE MIXES & PLACING

1. ALL CONCRETE SHALL DEVELOP A MINIMUM COMPRESSIVE STRENGTH AT THE END OF THE TWENTY EIGHTH (28) DAYS WITH CORRESPONDING MAXIMUM SIZE AGGREGATE AND SLUMPS AS FOLLOWS.

LOCATION	28 DAYS STRENGTH	MAX. SIZE OF AGG.	MAX. SLUMP
ALL OTHERS, INCLUDING			
SUSPENDED SLAB	3000 PSI (20.7 MPa)	20 mm	100 mm
COLUMNS	3000 PSI (20.7 MPa)	20 mm	100 mm
BEAMS, SLABS	3000 PSI (20.7 MPa)	20 mm	100 mm
SLAB ON FILL	3000 PSI (20.7 MPa)	20 mm	100 mm

2. MAINTAIN MINIMUM CONCRETE COVER FOR REINFORCING STEEL AS FOLLOWS.

SUSPENDED SLABS	20mm
SLAB ON GRADE	40mm
WALLS ABOVE GRADE	25mm
BEAM STIRRUPS AND COLUMN TIES	40mm
WHERE CONCRETE IS EXPOSED	
TO EARTH BUT POURED AGAINST FORMS	50mm
WHERE CONCRETE IS DEPOSITED	
DIRECTLY AGAINST EARTH	75mm

3. CONCRETE SHALL BE DEPOSITED IN ITS FINAL POSITION WITHOUT SEGREGATION. RE-HANDLING OR PLACING SHALL BE DONE PREFERABLY WITH BUGGIES, BUCKETS OR WHEELBORROWS, NO CHUTES WILL BE ALLOWED EXCEPT TO TRANSFER CONCRETE FROM HOPPERS TO BUGGIES, WHEELBORROWS OR BUCKETS IN WHICH CASE THEY SHALL NOT EXCEED SIX (6) METERS IN AGGREGATE LENGTH.
4. NO DEPOSITING OF CONCRETE SHALL BE ALLOWED WITHOUT THE USE OF VIBRATORS UNLESS AUTHORIZED IN WRITING BY THE DESIGNERS AND ONLY FOR UNUSUAL CONDITIONS WHERE VIBRATIONS ARE EXTREMELY DIFFICULT TO ACCOMPLISH.
5. ALL ANCHOR BOLTS, DOWELS, AND OTHER INSERTS, SHALL BE PROPERLY POSITIONED & SECURED IN PLACE PRIOR TO PLACING OF CONCRETE.
6. ALL CONCRETE SHALL BE KEPT MOIST FOR A MINIMUM OF SEVEN (7) CONSECUTIVE DAYS IMMEDIATELY AFTER POURING BY THE USE OF WET BURLAP, FOG SPRAYING, CURING COMPOUNDS OR OTHER APPROVED METHODS.
7. STRIPPING OF FORMS AND SHORES:

FOUNDATION	24 HRS.
SUSPENDED SLAB EXCEPT WHEN	
ADDITIONAL LOADS ARE IMPOSED	8 DAYS

WALLS	21 DAYS
BEAMS	14 DAYS
COLUMNS	21 DAYS

8. THE CONTRACTOR SHALL SUBMIT THE SCHEDULE OF POURING AND THE LOCATION OF THE CONSTRUCTION JOINTS TO THE STRUCTURAL ENGINEER AT LEAST FOUR (4) DAYS PRIOR TO THE POURING FOR APPROVAL.
9. THE CONTRACTOR SHALL FURNISH AND MAINTAIN ADEQUATE FORMS AND SHORING UNTIL THE CONCRETE MEMBERS HAVE ATTAINED THEIR WORKING CONDITION AND STRENGTH.

NOTES ON FOOTINGS

1. FOOTINGS ARE DESIGNED FOR AN ALLOWABLE SOIL BEARING PRESSURE OF 120 KPA. CONTRACTOR SHALL REPORT TO THE ENGINEER, IN WRITING, THE ACTUAL SOIL CONDITIONS UNCOVERED AND CONFIRM ACTUAL BEARING CAPACITY OF SOIL BEFORE DEPOSITING CONCRETE.
2. FOOTING SHALL REST AT LEAST 1500MM BELOW NATURAL GRADE LINES UNLESS OTHERWISE INDICATED IN THE PLANS. NO FOOTING SHALL REST OF FILL.
3. MINIMUM CONCRETE PROTECTION FOR REINFORCEMENTS SHALL BE 75MM CLEAR FOR CONCRETE DEPOSITED THE GROUND AND 50MM FOR CONCRETE DEPOSITED AGAINST A FORMWORK.

NOTES ON REINFORCEMENT

1. UNLESS OTHERWISE NOTED IN THE PLANS, THE YIELD STRENGTH OF REINFORCING BARS SHALL BE:

A. FOOTINGS, FOOTING BEAMS AND GIRDERS	FY = 414 MPA (60,000 PSI)
B. COLUMNS AND SHEAR WALLS	FY = 414 MPA (60,000 PSI)
C. BEAMS AND GIRDERS	FY = 414 MPA (60,000 PSI)
D. NON-LOAD BEARING WALL PARTITIONS, BEDDED SLABS, FLOOR AND ROOF SLABS, PARAPETS, CATCH BASIN, SIDE WALK	FY = 227.5 MPA (33,000 PSI)

2. ALL REINFORCING BARS SIZE 10MM OR LARGER SHALL BE DEFORMED IN ACCORDANCE WITH ASTM A 706. BARS SMALLER THAN 10MM MAY BE PLAIN.
3. SPLICES SHALL BE SECURELY WIRED TOGETHER & SHALL LAP OR EXTEND IN ACCORDANCE WITH TABLE A AND TABLE B (TABLE OF LAP SPLICE & ANCHORAGE LENGTH) UNLESS OTHERWISE SHOWN ON DRAWINGS, SPLICES SHALL BE STAGGERED WHENEVER POSSIBLE.

NOTES ON CONCRETE SLABS

1. ALL SLAB REINFORCEMENTS SHALL BE 20MM CLEAR MINIMUM FROM BOTTOM AND FROM THE TOP OF SLAB.
2. UNLESS OTHERWISE SHOWN, REINFORCEMENT IN CONTINUOUS ELEVATED SLAB SHALL BE CUT AS FOLLOWS:

TYPICAL BAR BENDING AND CUTTING DETAILS FOR SLABS

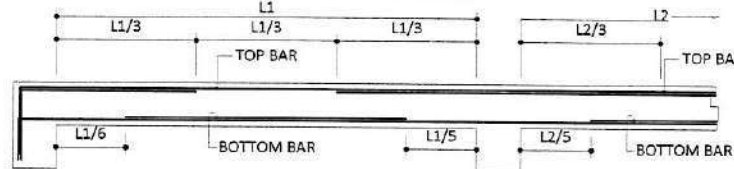

3. IF SLABS ARE REINFORCED BOTH WAYS BARS ALONG THE SHORTER SPAN SHALL BE PLACED BELOW THOSE ALONG THE LONG SPAN AT THE CENTER AND OVER THE LONGER SPAN FOR REINFORCING BARS NEAR THE SUPPORTS. THE SPACING OF THE BARS AT THE COLUMN STRIPS SHALL NOT BE MORE THAN ONE AND A HALF (1 1/2) SLAB THICKNESS.
4. TEMPERATURE BARS FOR SLAB SHALL BE GENERALLY PLACED NEAR THE FACE IN TENSION AND SHALL NOT BE LESS THAN 0.0025 X GROSS CROSS-SECTIONAL AREA (Ag) OF THE SLAB (SEE SCHEDULE BELOW):

THICKNESS	MINIMUM TEMPERATURE BARS
100 mm	10 mm Ø @ 250 mm EACH WAY
125 mm	10 mm Ø @ 225 mm EACH WAY
150 mm	10 mm Ø @ 185 mm EACH WAY
175 mm	10 mm Ø @ 150 mm EACH WAY
200 mm	10 mm Ø @ 140 mm EACH WAY

5. UNLESS OTHERWISE NOTED IN THE PLANS, ALL BEDDED SLABS SHALL BE REINFORCED WITH 10mm Ø @ 250mm O.C. EACH WAY TO CENTER OF SLAB AND CONSTRUCTION JOINTS FOR SAME SHALL NOT BE LESS THAN 3.65 METERS APART.
6. PROVIDE EXTRA REINFORCEMENTS FOR CORNER SLAB (TWO ADJACENT DISCONTINUOUS EDGES) AS SHOWN BELOW.
7. CONCRETE SLAB REINFORCEMENTS SHALL BE PROPERLY SUPPORTED WITH 10MM Ø STEEL CHAIR OR APPROVED EQUIVALENT SPACED AT 1.0 METER ON CENTER BOTH WAYS.

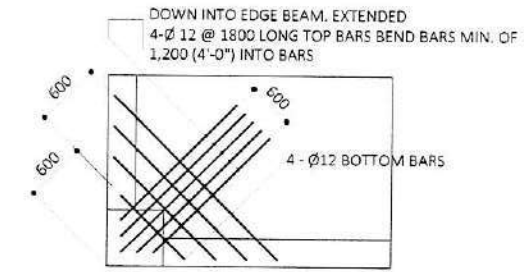

NOTES ON COLUMNS

1. PROVIDE EXTRA SETS OF TIES AT 100MM O.C. FOR TIED COLUMN REINFORCEMENT ABOVE AND BELOW BEAM-COLUMN CONNECTIONS FOR A DISTANCE FROM FACE OF CONNECTION EQUAL TO THE GREATER OF THE OVERALL THICKNESS OF COLUMN, 1/6 THE CLEAR HEIGHT OF COLUMN OR 450MM.
2. COLUMN TIES SHALL BE PROTECTED EVERYWHERE BY A COVERING OF CONCRETE CAST MONOLITHICALLY WITH THE CORE WITH THE MINIMUM THICKNESS OF 40MM AND NOT LESS THAN 40 TIMES THE MAXIMUM SIZE OF COARSE AGGREGATE IN MILLIMETERS.
3. WHERE COLUMNS CHANGE IN SIZE, VERTICAL REINFORCEMENTS SHALL BE OFFSET AT A SLOPE OF NOT MORE THAN 1 IN 6 AND EXTRA 10MM TIES AT 100MM SHALL BE PROVIDED THROUGHOUT THE OFFSET REGION.
4. UNLESS OTHERWISE INDICATED IN THE PLANS, LAP SPLICES FOR VERTICAL COLUMN REINFORCEMENT SHALL BE MADE WITHIN THE CENTER HALF OF COLUMN HEIGHT, AND THE SPLICE LENGTH SHALL NOT BE LESS THAN 40 BAR DIAMETERS.

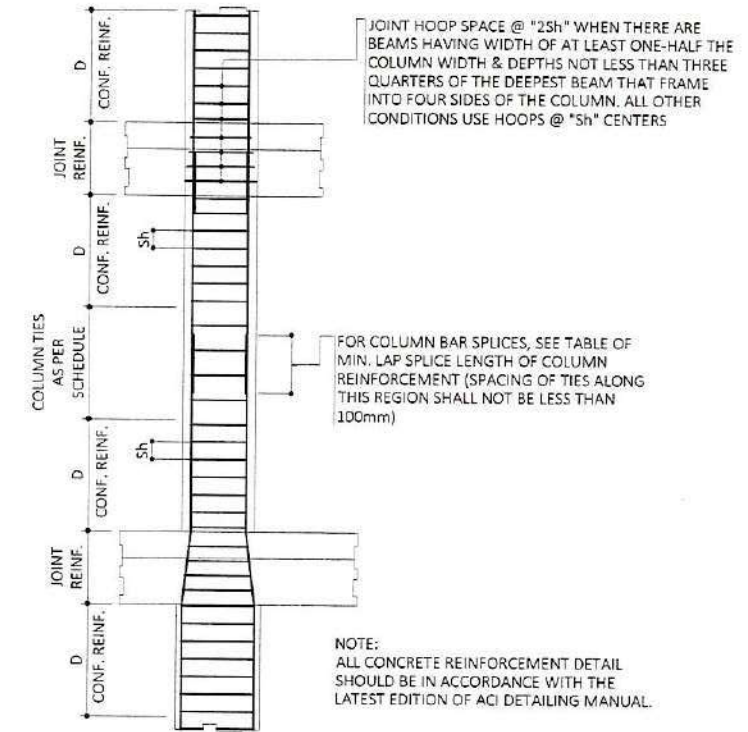

TYPICAL COLUMN ELEVATION SHOWING DOWELS AND TIES SPACING

NOTES ON BEAMS AND GIRDERS

1. UNLESS, OTHERWISE NOTED IN PLANS, CAMBER ALL BEAMS AND GIRDER AT LEAST 6MMØ FOR EVERY 4.5M OF SPAN. EXCEPT CANTILVERS FOR WHICH THE CAMBER SHALL BE AS NOTED IN PLANS OR AS ORDERED BY THE ENGINEER BUT IN NO CASE LESS THAN 20MM FOR EVERY 3.0M OF FREE SPAN.
2. TYPICAL BARS BENDING AND CUTTING DETAILS FOR BEAMS SHALL BE AS SHOWN IN FIGURE B-2.
3. IF THE BEAM REINFORCING BARS END IN A WALL, THE CLEAR DISTANCE FROM THE BAR TO THE FARTHER FACE OF THE WALL NOT BE LESS THAN 25MM. EMBEDMENT LENGTH SHALL BE AS SHOWN IN TABLE 'A' FOR TENSION BARS AND TABLE 'B' FOR COMPRESSION BARS UNLESS SPECIFIED IN PLAN. TOP BAR SHALL NOT BE SPLICED WITHIN THE COLUMN OR WITHIN A DISTANCE TWICE THE MEMBER DEPTH FROM THE FACE OF THE COLUMN. AT LEAST TWO STIRRUPS SHALL BE PROVIDED AT ALL SPLICES.
4. IF THERE ARE TWO OR MORE LAYERS OF REINFORCING BARS, USE 25MMØ BAR SEPARATORS SPACED AT 1.0M ON CENTER. IN NO CASE SHALL THERE BE LESS THAN TWO (2) SEPARATORS BETWEEN TWO LAYERS OF BARS.
5. MINIMUM CONCRETE PROTECTION FOR REINFORCING BARS OR STEEL SHAPES SHALL BE AS SHOWN IN FIGURE B-1 UNLESS SPECIFIED ELSEWHERE.

<p>ARCH. HAZELINE N. TIBANGAY, UAP PRC REG. NO. 028540 - NOV.18, 2024 PTR NO. - LA TRINIDAD -</p> <p>ARCHITECT</p>	<p>ENGINEER</p>	<p>OWNER/ PROJECT TITLE/ LOCATION</p> <p>REPAIR OF THE POULTRY OFFICE BUILDING BSU LA TRINIDAD CAMPUS, BALILI, LA TRINIDAD, BENGUET</p>	<p>CONFORME:</p> <p>BERNARD B. BALAG JR. END-USERS</p>	<p>RECOMMENDING APPROVAL:</p> <p>ALLAN CASALDO SACPA SECTOR VICE PRESIDENT</p>	<p>APPROVED:</p> <p>FELIPE SALAING COMILA PRESIDENT</p>	<p>SHEET CONTENT:</p> <p>AS SHOWN</p>	<p>SHEET</p> <p>S 01-05</p>
			<p>DRAFTED BY: ERGD 2024</p>	<p>CONFORME:</p>	<p>RECOMMENDING APPROVAL:</p>	<p>APPROVED:</p>	<p>SHEET CONTENT:</p>

6. WHEN A BEAM CROSSES A GIRDER, REST BEAM ON TOP OF GIRDER BARS, BEAM REINFORCING BAR SHALL BE SYMMETRICAL ABOUT CENTER LINE WHENEVER POSSIBLE.

7. GENERALLY, NO SPLICE SHALL BE PERMITTED AT POINTS WHERE CRITICAL BENDING STRESSES OCCUR. SPLICES WHERE SO PERMITTED SHALL BE INDICATED IN THE TABLE 'A' AND 'B'. WELDED SPLICES SHALL DEVELOP IN TENSION AT LEAST 125% OF THE SPECIFIED YIELD STRENGTH OF THE BAR. NOT MORE THAN 50% OF THE BARS AT ANY ONE SECTION IS ALLOWED TO BE SPLICED THEREIN.

NOTES ON CONCRETE HOLLOW BLOCK WALLS

- UNLESS OTHERWISE SHOWN IN THE PLANS, ALL CONCRETE HOLLOW BLOCKS AND CERAMIC BLOCKS ARE REINFORCED AS SHOWN IN THE SCHEDULE OF CONCRETE HOLLOW BLOCKS AND CERAMIC BLOCK REINFORCEMENT.
- PROVIDE 150mm x 300mm STIFFENER COLUMN REINFORCED WITH 4-12mm WITH 6mmØ TIES AT 150mm ON CENTER WHERE CONCRETE HOLLOW BLOCK TERMINATES AND AT EVERY 3.0m LENGTH OF CONCRETE HOLLOW BLOCK WALLS UNLESS NOTED IN THE STRUCTURAL PLANS.

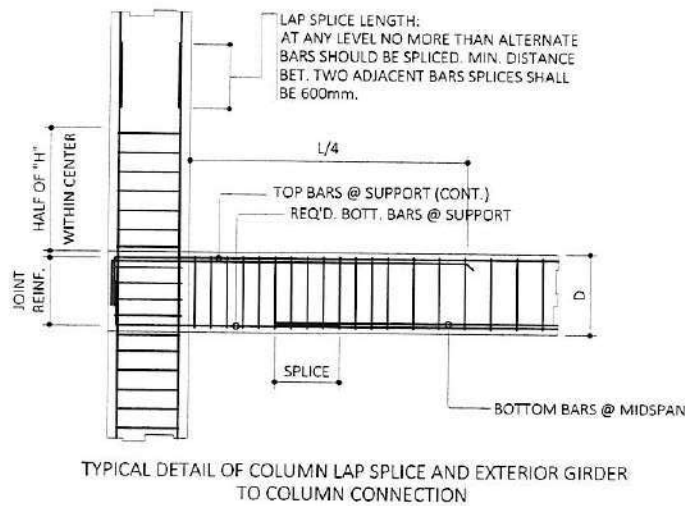

BLOCK THICKNESS	REINFORCEMENT		NOTES
	HORIZONTAL	VERTICAL	
75mm	10mmØ @ 600mm OC.	10mmØ @ 600mm OC.	A. MINIMUM LAPS AT SPLICE = 0.25m B. PROVIDE RIGHT ANGLED REINFORCEMENT AT CORNERS 0.92m LONG C. WHERE CHB OR CERAMIC BLOCK WALL DOWELS JOIN COL. R.C. BEAMS AND WALL DOWELS WITH THE SAME SIZE AS VERTICAL OR HORIZONTAL REINFORCEMENT SHALL BE PROVIDED.
125mm	10mmØ @ 600mm OC.	10mmØ @ 600mm OC.	
150mm	10mmØ @ 600mm OC.	10mmØ @ 600mm OC.	
200mm	12mmØ @ 600mm OC.	12mmØ @ 600mm OC.	

NOTES ON EMBEDDED PIPES

- ALL EMBEDDED PIPES FOR UTILITIES, ETC., THAT PASS THROUGH BEAMS SHALL NOT EXCEED 100mm IN DIAMETER OR 1/3 BEAM DEPTH WHICHEVER IS LESS, UNLESS OTHERWISE APPROVED IN WRITING BY THE STRUCTURAL ENGINEER.
- NO PIPES SHALL BE ALLOWED TO PASS THROUGH BEAMS VERTICALLY.
- NO PIPES SHALL BE EMBEDDED IN COLUMNS.

NOTES ON STIRRUPS

- ALL REINFORCEMENT SHALL BE BENT COLD UNLESS OTHERWISE PERMITTED BY THE STRUCTURAL ENGINEER.
- REINFORCEMENT PARTIALLY EMBEDDED IN CONCRETE SHALL NOT BE FILLED BENT, EXCEPT AS SHOWN IN THE DESIGN DRAWINGS OR PERMITTED BY THE STRUCTURAL ENGINEER.
- TIES AND CLOSE STIRRUPS MUST BE BENT AT 135°.

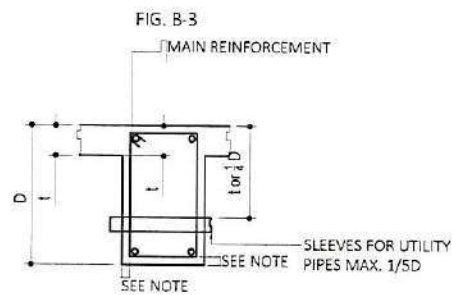
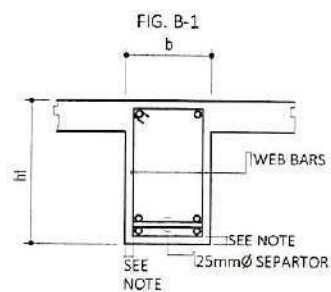

TYPICAL DETAILS FOR SLEEVES THRU CONCRETE BEAM

NOTE
 1: 20mm CLEAR FOR JOIST
 40mm CLEAR FOR BEAMS AND GIRDERS

TABLE 'A'
 TENSION BARS
 EMBEDMENT LENGTHS AND LAPPED SPLICES IN MILLIMETERS

BAR SIZE (DEFORMED)	f _c = 20.7MPa (3,000 psi)		f _c = 27.6MPa (4,000 psi)	
	EMBEDMENT	LAPPED	EMBEDMENT	LAPPED
10mm DIA.	300	300	300	300
12mm DIA.	300	300	300	300
16mm DIA.	300	400	300	400
20mm DIA.	400	550	350	500
25mm DIA.	600	800	550	750
28mm DIA.	750	1000	650	850
32mm DIA.	950	1300	850	1100

TABLE 'B'
 COMPRESSION BARS
 EMBEDMENT LENGTHS AND LAPPED SPLICES IN MILLIMETERS

BAR SIZE (DEFORMED)	f _c = 20.7MPa (3,000 psi)		f _c = 27.6MPa (4,000 psi)	
	EMBEDMENT	LAPPED	EMBEDMENT	LAPPED
10mm DIA.	225	300	200	300
12mm DIA.	275	300	250	300
16mm DIA.	350	400	325	400
20mm DIA.	450	500	350	500
25mm DIA.	550	625	550	625
28mm DIA.	625	675	625	675
32mm DIA.	700	775	700	775

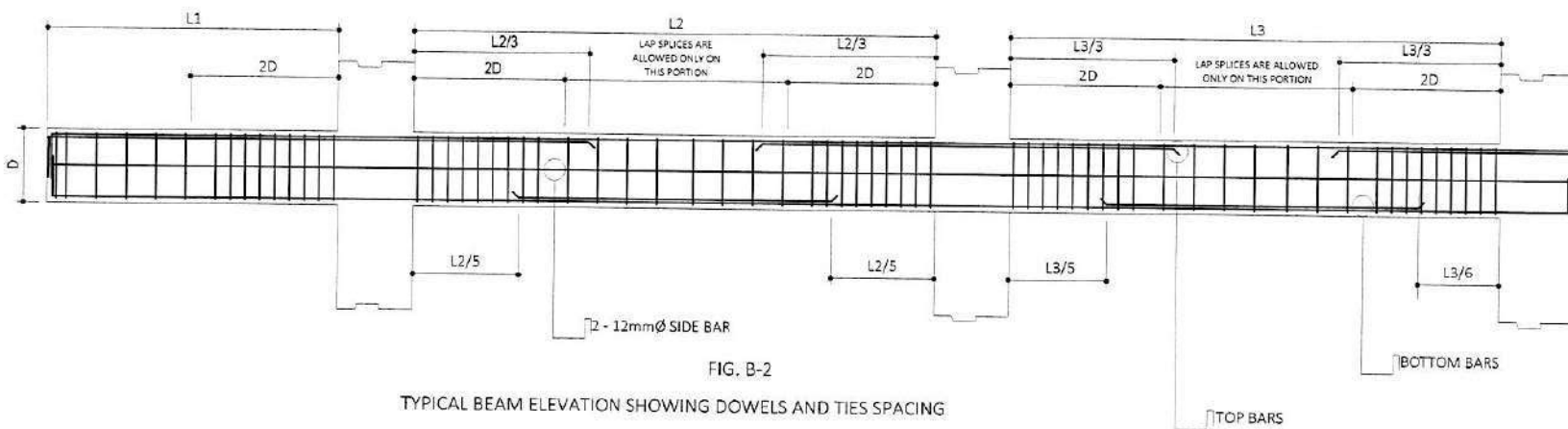



TYPICAL BEAM ELEVATION SHOWING DOWELS AND TIES SPACING

NOTES ON WELDS

- USE E70xx ELECTRODES FOR ALL MEMBERS WELDED.
- WELDS SHALL DEVELOP THE FULL STRENGTH OF MEMBERS JOINED UNLESS OTHERWISE SHOWN OR DETAILED IN THE DRAWINGS.

NOTES ON STRUCTURAL STEEL

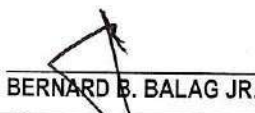
- STRUCTURAL STEEL TO BE USED FOR FABRICATION AND ERECTION OF THIS STRUCTURE SHALL COMPLY WITH ALL THE PERTINENT PROVISIONS OF AISC SPECIFICATION FOR THE DESIGN, FABRICATION AND ERECTION OF STRUCTURAL STEEL FOR BUILDING LATEST EDITION.
- ALL STRUCTURAL STEEL SHAPES SHALL CONFORM TO ASTM A36 STRUCTURAL STEEL UNLESS OTHERWISE INDICATED.
- ALL WELDED CONNECTIONS SHALL DEVELOP THE FULL STRENGTH OF THE MEMBERS CONNECTED.
- UNLESS OTHERWISE SPECIFIED, ALL WELDING RODS SHALL CONFORM AWS E60 ELECTRODES.
- ALL BOLTS USED UNLESS OTHERWISE SPECIFIED SHALL BE ASTM A 307 BOLTS.

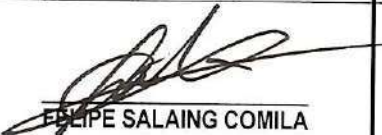
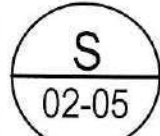
ARCH. HAZELINE N. TIBANGAY, UAP PRC REG. NO. 028540 - NOV.18, 2024 PTR NO. - LA TRINIDAD - ARCHITECT	ENGINEER	DRAFTED BY: ERGD 2024	OWNER/ PROJECT TITLE/ LOCATION  REPAIR OF THE POULTRY OFFICE BUILDING BSU LA TRINIDAD CAMPUS, BALILI, LA TRINIDAD, BENGUET	CONFORME:  BERNARD B. BALAG JR. END USERS	RECOMMENDING APPROVAL:  ALLAN CASALDO SACPA SECTOR VICE PRESIDENT	APPROVED:  FELIPE SALAING COMILA PRESIDENT	SHEET CONTENT: AS SHOWN	SHEET 

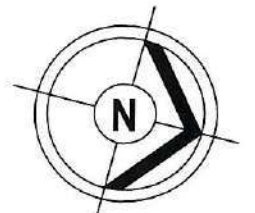

C O L U M N S C H E D U L E				
LEVEL	COLUMN MARK	COLUMN DIMENSION	REINFORCING BAR	
			MAIN BAR	LATERAL TIES
FOOTING TO ROOF	C1	300mm X 300mm	6PCS - 16mm Dia.	10mm DIA. - 2 @75mm, 5 @100mm, REST @150mm TO MIDHEIGHT
FOOTING TO STAIR LANDING	C2	300mm X 300mm	4PCS - 16mm Dia.	10mm DIA. - 2 @100mm, 5 @150mm, REST @200mm TO MIDHEIGHT

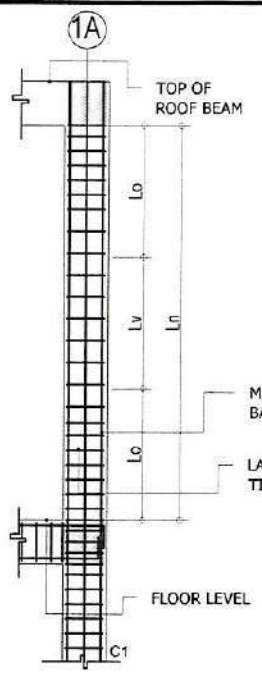

150 mm THK. CONCRETE SUSPENDED SLAB REINFORCED WITH 10mm Dia. BAR SPACED @ 0.15m, O.C. - B/W
 100 mm THK. CONCRETE SLAB ON FILL REINFORCED WITH 10mm Dia. BAR SPACED @ 0.2m, O.C. - B/W

B E A M S C H E D U L E										
BEAM MARK	BEAM DIMENSIONS (mm) W H	DESCRIPTION	BAR SIZE	REINFORCING BARS						STIRRUPS (10mm Ø RSB UNLESS OTHERWISE INDICATED)
				LEFT SUPPORT		MIDSPAN		RIGHT SUPPORT		
B-1	250 300	BEAM	16mm DIA.	TOP 2	BOTTOM 3	TOP 2	BOTTOM 3	TOP 2	BOTTOM 3	2 @75mm, 10 @100mm, REST @150mm UP TO MIDLENGTH
B-2	250 300	BEAM	16mm DIA.	2	2	2	2	2	2	2 @75mm, 10 @100mm, REST @150mm UP TO MIDLENGTH/END
RB-1	250 300	ROOF BEAM	16mm DIA.	2	3	2	3	2	3	2 @75mm, 10 @100mm, REST @150mm UP TO MIDLENGTH

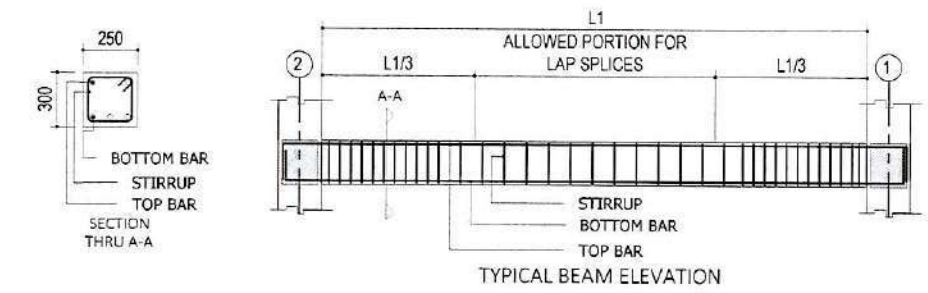

S L A B S C H E D U L E								
SLAB MARK	THICKNESS,mm	REBAR SIZE	REINFORCING BAR ALONG SHORT SPAN				REINFORCING BAR ALONG LONG SPAN	
			LEFT SUPPORT		MIDSPAN		RIGHT SUPPORT	
S1	100	10	TOP 200	BOTTOM 200	TOP 200	BOTTOM 200	TOP 200	BOTTOM 200
REMARKS		REBAR SIZE	LEFT SUPPORT TOP	LEFT SUPPORT BOTTOM	MIDSPAN TOP	MIDSPAN BOTTOM	RIGHT SUPPORT TOP	RIGHT SUPPORT BOTTOM
SUSPENDED SLAB		10mm DIA.	200	200	200	200	200	200

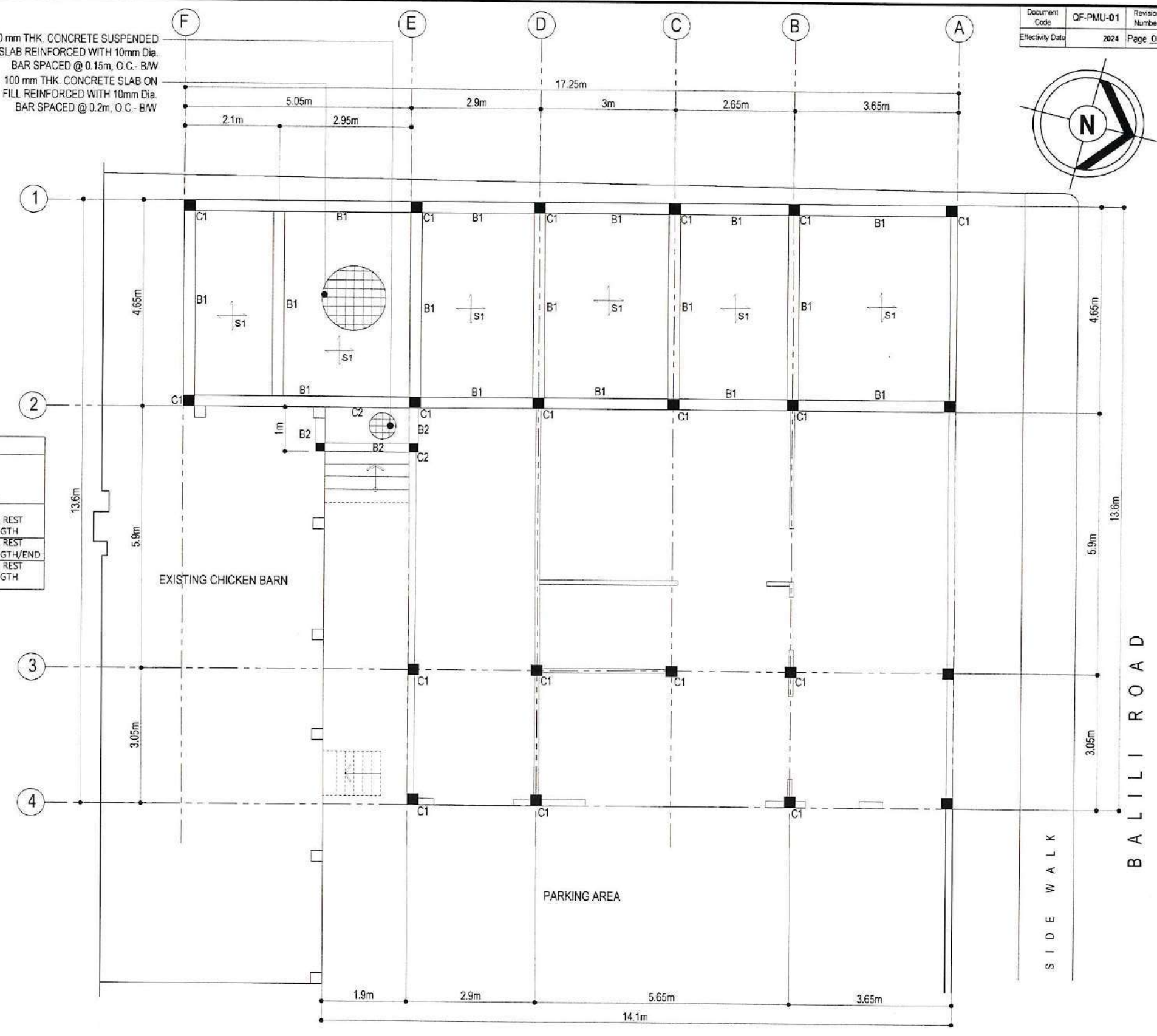
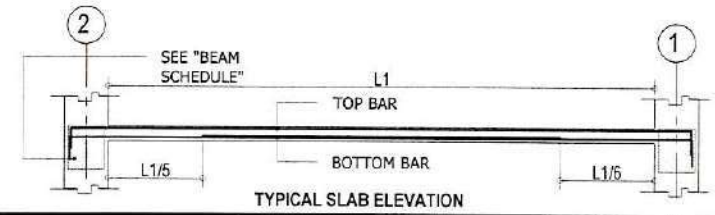

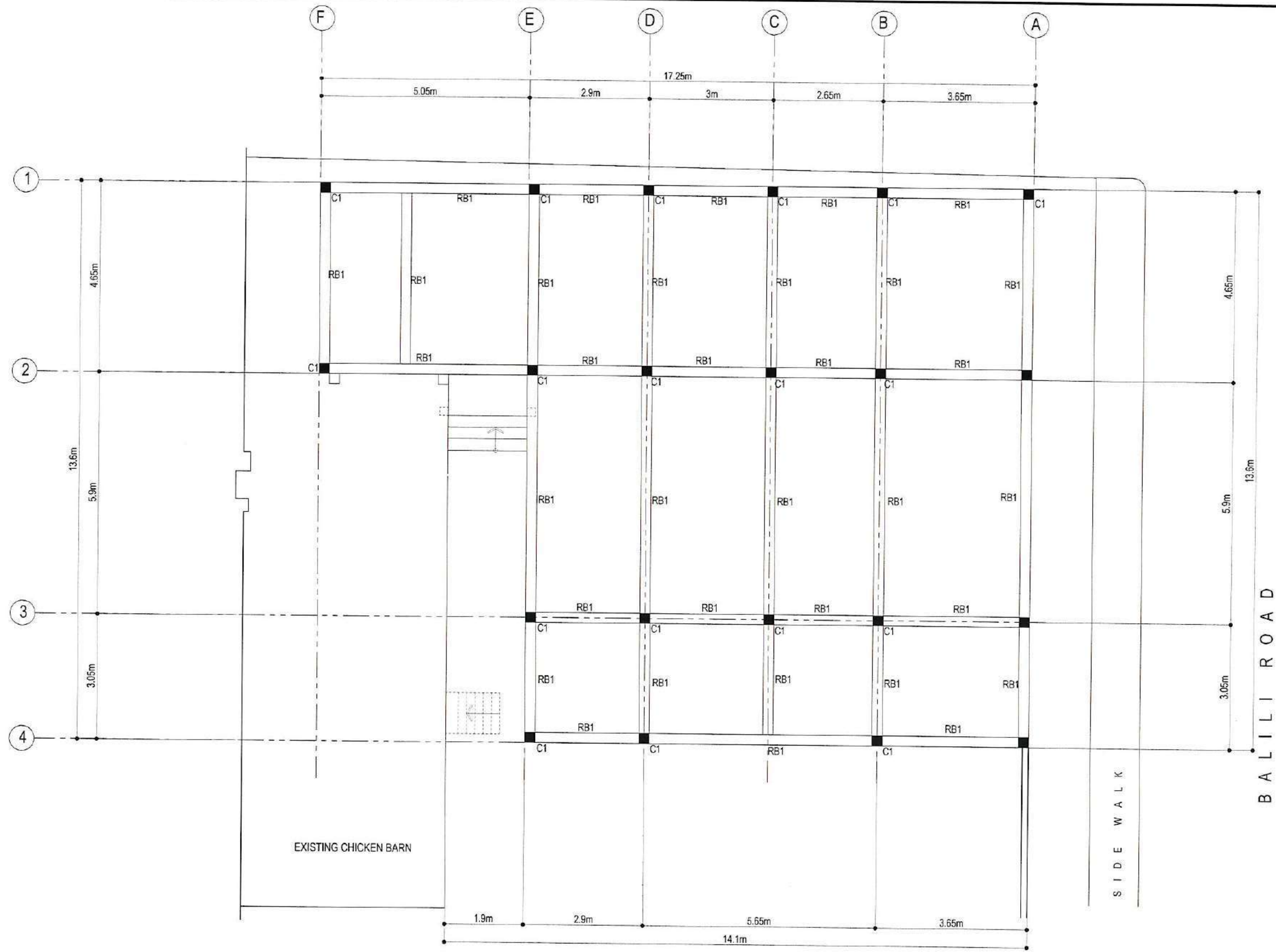
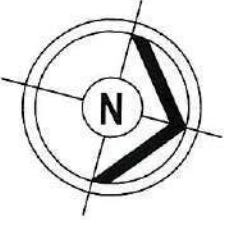

S FLOOR FRAMING LAYOUT
 SCALE: 1:100 MTS.

ARCH. HAZELINE N. TIBANGAY, UAP PRC REG. NO. 028540 - NOV. 18, 2024 PTR NO. - LA TRINIDAD - ARCHITECT	ERGD 2024 ENGINEER	OWNER/ PROJECT TITLE/ LOCATION REPAIR OF THE POULTRY OFFICE BUILDING BSU LA TRINIDAD CAMPUS, BALILI, LA TRINIDAD, BENGUET	CONFORME: BERNARD B. BALAG JR. END-USER	RECOMMENDING APPROVAL: ALLAN CASALDO SACPA SECTOR VICE PRESIDENT	APPROVED: FELIPE SALAING COMILA PRESIDENT	SHEET CONTENT: AS SHOWN	SHEET S 03-05
		DRAFTED BY: ERGD 2024					

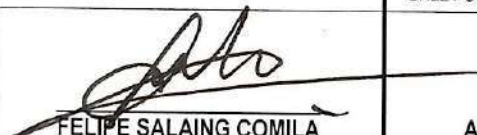
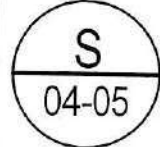

ROOF BOTTOM CHORD FRAMING LAYOUT
 SCALE: 1:100 MTS.

ARCH. HAZELINE N. TIBANGAY, UAP PRC REG. NO. 028540 - NOV. 18, 2024 PTR NO. - LA TRINIDAD - ARCHITECT	ENGINEER	DRAFTED BY: ERGD 2024	OWNER/ PROJECT TITLE/ LOCATION  REPAIR OF THE POULTRY OFFICE BUILDING BSU LA TRINIDAD CAMPUS, BALILI, LA TRINIDAD, BENGUET	CONFORME:  BERNARD B. BALAG JR. END-USERS	RECOMMENDING APPROVAL:  ALLAN CASALDO SACPA SECTOR VICE PRESIDENT	APPROVED:  FELIPE SALAING COMILA PRESIDENT	SHEET CONTENT: AS SHOWN	SHEET 

50mm X 75mm C- PURLINS
 SPACED @ 50CM O.C.

SCHEDULE OF TRUSS- 5		
MARK	DESCRIPTION	SIZE
W1	TOP CHORD	2 - 2" x 2"
W1	BOTTOM CHORD	1 - 2" x 2"
W2	WEB MEMBERS	1 - 1" x 1"

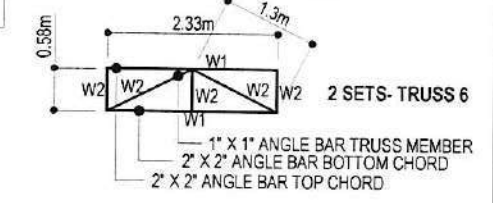

SCHEDULE OF TRUSS- 5		
MARK	DESCRIPTION	SIZE
W1	TOP/BOTTOM CHORD	2 - 2" x 2"
W2	WEB MEMBERS	2 - 1" x 1"

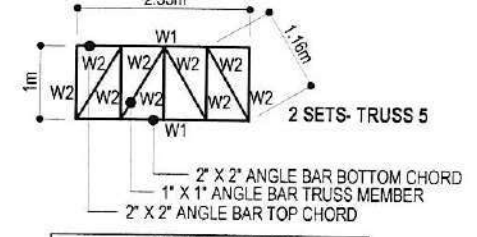

SCHEDULE OF TRUSS- 4		
MARK	DESCRIPTION	SIZE
W1	TOP/BOTTOM CHORD	2 - 2" x 2"
W2	WEB MEMBERS	2 - 1" x 1"

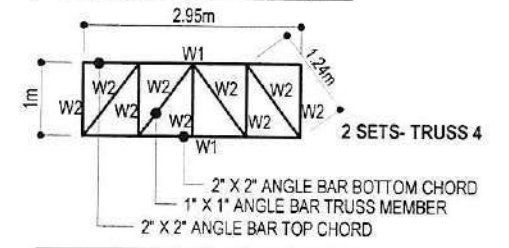

SCHEDULE OF TRUSS- 3		
MARK	DESCRIPTION	SIZE
W1	TOP/BOTTOM CHORD	2 - 2" x 2"
W2	WEB MEMBERS	2 - 1" x 1"

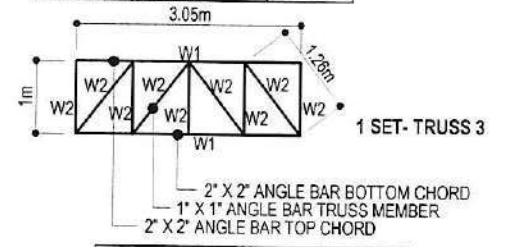

SCHEDULE OF TRUSS- 2		
MARK	DESCRIPTION	SIZE
W1	TOP/BOTTOM CHORD	2 - 2" x 2"
W2	WEB MEMBERS	2 - 1" x 1"

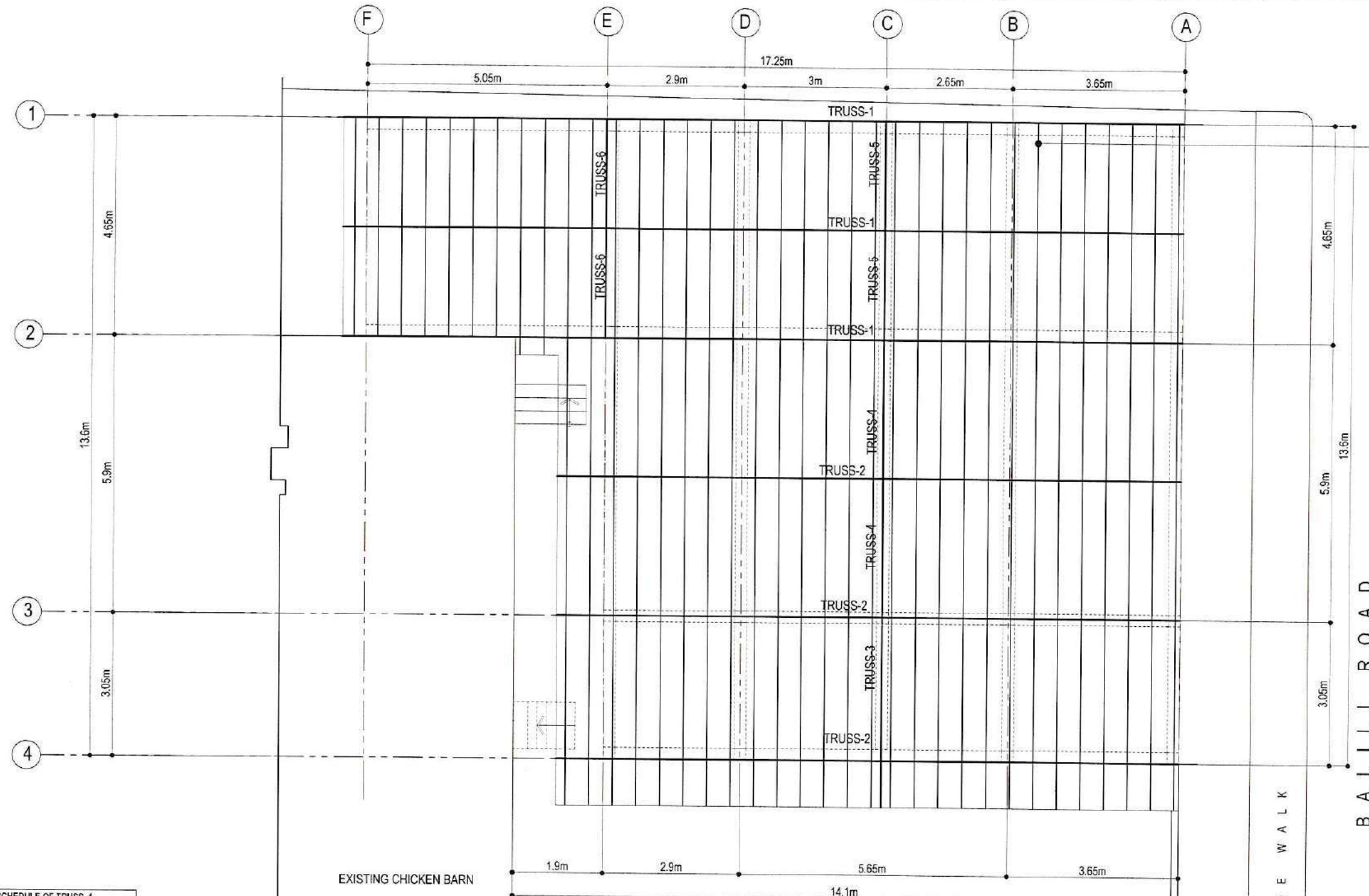
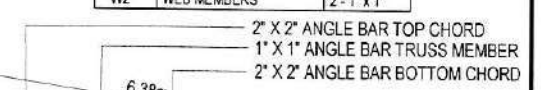



ROOF TOP CHORD FRAMING LAYOUT
 SCALE: 1:100 MTS.

SCHEDULE OF TRUSS- 1		
MARK	DESCRIPTION	SIZE
W1	TOP/BOTTOM CHORD	2 - 2" x 2"
W2	WEB MEMBERS	2 - 1" x 1"

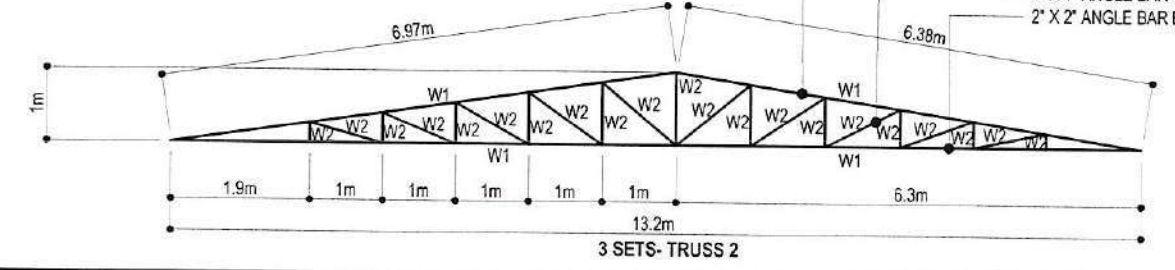
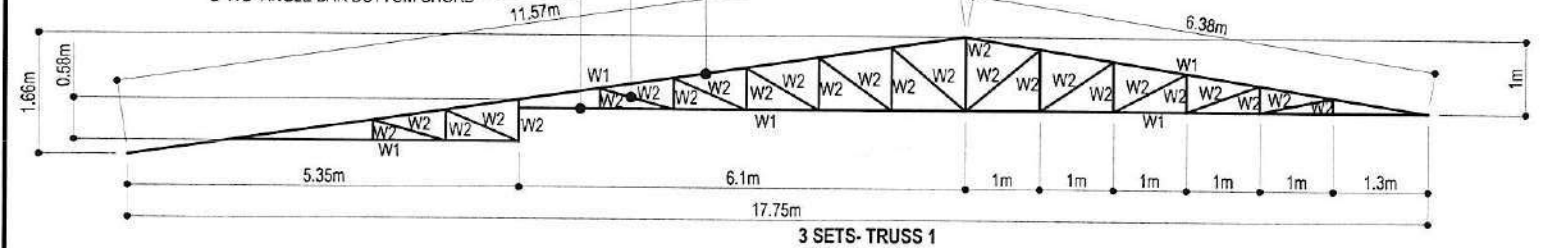
2" X 2" ANGLE BAR TOP CHORD
 1" X 1" ANGLE BAR TRUSS MEMBER
 2" X 2" ANGLE BAR BOTTOM CHORD

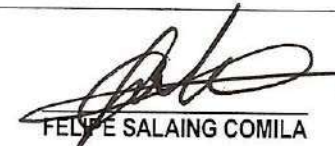
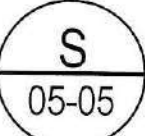

ARCH. HAZELINE N. TIBANGAY, UAP PRC REG. NO. 028540 - NOV. 18, 2024 PTR NO. - LA TRINIDAD - ARCHITECT	ERGD 2024 DRAFTED BY:	OWNER/ PROJECT TITLE/ LOCATION  REPAIR OF THE POULTRY OFFICE BUILDING BSU LA TRINIDAD CAMPUS, BALILI, LA TRINIDAD, BENGUET	CONFORME:  BERNARD B. BALAG JR. END-USERS	RECOMMENDING APPROVAL:  ALLAN CASALDO SACPA SECTOR VICE PRESIDENT	APPROVED:  FELIPE SALAING COMILA PRESIDENT	SHEET CONTENT: AS SHOWN	SHEET  05-05
		ARCHITECT	ENGINEER	ENGINEER	END-USERS	SECTOR VICE PRESIDENT	PRESIDENT