



Republic of the Philippines
Benguet State University
 2601 La Trinidad, Benguet
 www.bsu.edu.ph

REQUEST FOR QUOTATION (RFQ)
(ALL ENTRIES ARE MANDATORY)

Name of Owner/ Corporation/ Cooperative/ Agency: _____

Name of Business : _____

Address: _____

Email address: _____ Telephone No. _____

QUOTATION NO. 65
 DATE: FEB 13 2025
 P.R. NO.: 2025-01-14
 ABC: Php. 225,000.00
 FUND SOURCE: SPRINT-Hort Project 1

The Benguet State University through its Bids and Awards Committee will undertake NP - SVP for the item/s listed below under the following terms and conditions:

- All entries must be written legibly and accurately.
- Delivery period is within 6 months calendar days.
- Warranty period shall be for a minimum of three months, in case of expendable supplies, and a minimum of one year in case of non- expendable supplies from date of acceptance by the University.
- Price validity shall be for a period of 30 calendar days.
- Compliance with specifications: Kindly specify in the column provided below whether the offer fully complies with the specifications or a counter offer.
- Deadline of submission of quotation is on or before 5:00 pm of Feb. 18, 2025. Offers may be submitted in sealed or open quotation in person, or through facsimile (074-661-1839) or email (procurement@bsu.edu.ph)
- The item/s shall be procured by: a) line item; b) lot; c) sub-lot
- Business Permit Number : _____, date of issue: _____, place of issue: _____, (If renewal of Business Permit is still on process, please indicate OR No: _____, date of OR: _____ for the payment of renewal).
- * PhilGEPS Registration Number: _____

SAMUEL S. POLIDEN
 Chairperson, BAC (Goods & Services)

College/Dept./Office: **CE-SPRINT-Hort Project 1**

Item No.	Qty	Unit	Item	Technical Specifications (Brand and Model)		ABC	Unit Cost	Total Cost
				COMPLY	COUNTER OFFER			
			CAPITAL OUTLAY, AGRICULTURAL EQUIPMENT					
1	1	unit	CARROT WASHER, Continuous Fed, Supply of Materials, Labor and Fabrication) see attached details			225,000.00		
			TOTAL			<u>225,000.00</u>		
			XXXXXXXXXX					

Counter offers:

Delivery Period: _____
 Warranty: _____
 Price Validity: _____

We hereby submit our quotations, accept the general conditions for the above items and be bound by our offer.

 Signature over Printed Name

 Date and Time of Receipt of RFQ

* Not a ground for disqualification for failure to indicate but required as a condition for award.

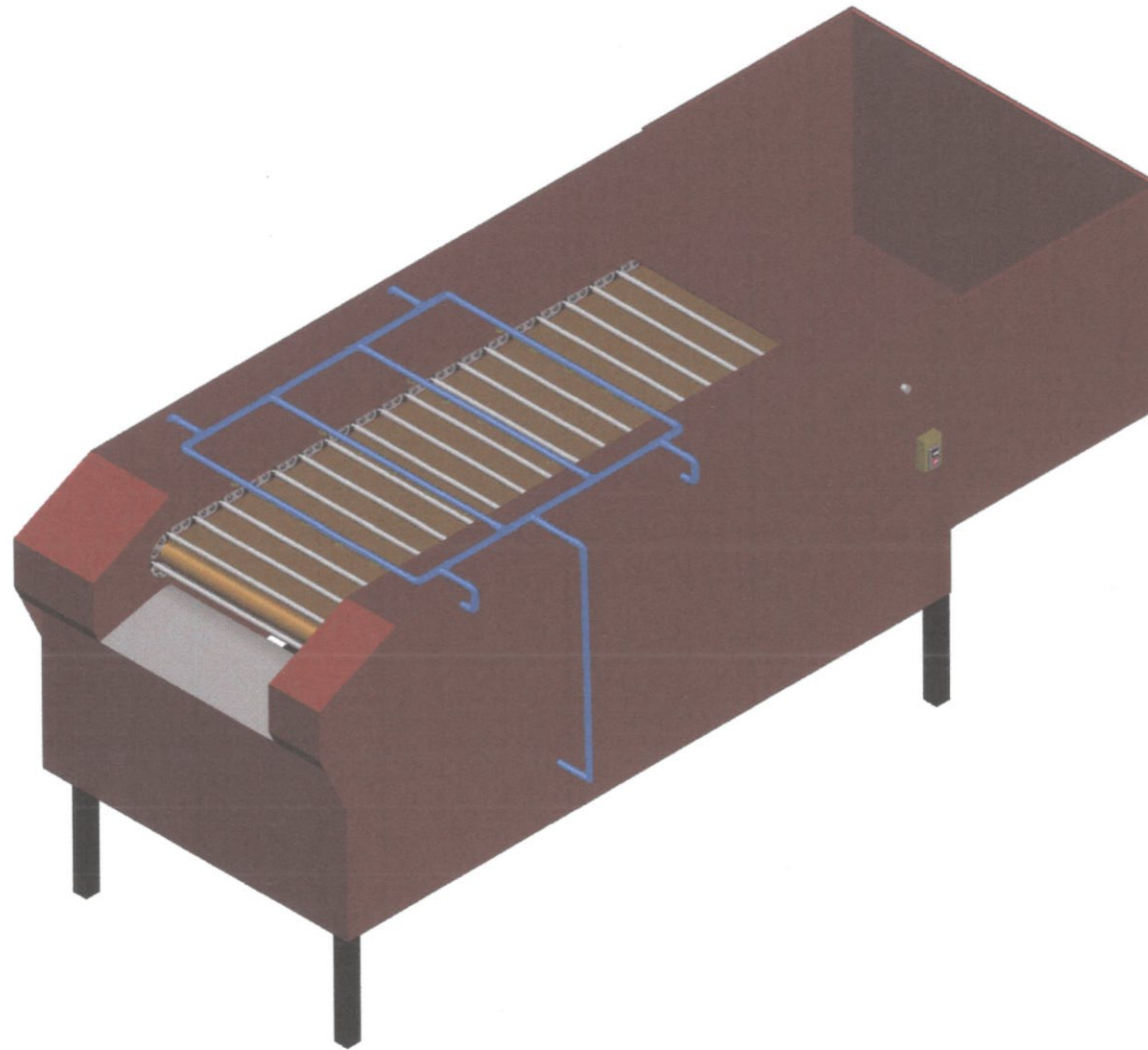

COLLEGE OF ENGINEERING
Benguet State University
 La Trinidad, Benguet

Project: SPRINT-Hort Project 1 - Postharvest Systems Improvement of Selected Horticultural Value Chains

Funding Agency:
 Philippine Council for Agriculture, Aquatic and Natural Resources Research and Development (PCAARRD)

Implementing Agency:
 Benguet State University

Prepared by: 
LEONARDO D. DUMALHIN
 Project Leader

Scope of Work:
 Supply of Materials, Labor and Fabrication of Continuous Fed Carrot Washer Machine

Sheet Content
MACHINE ISOMETRIC VIEW

Date:

Scale 1 : NTS

Page No: $\frac{1}{5}$

Note: Design may vary depending on the result of pre testing

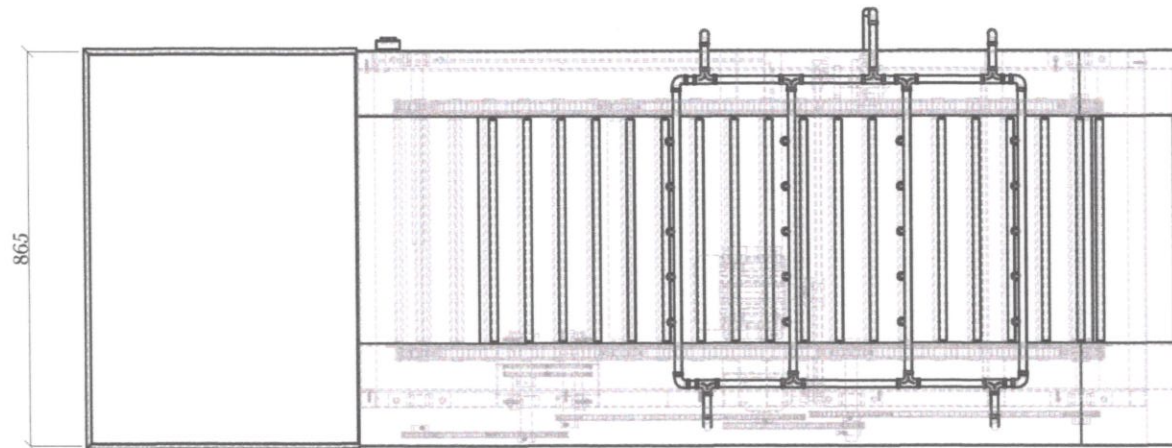

TOP VIEW

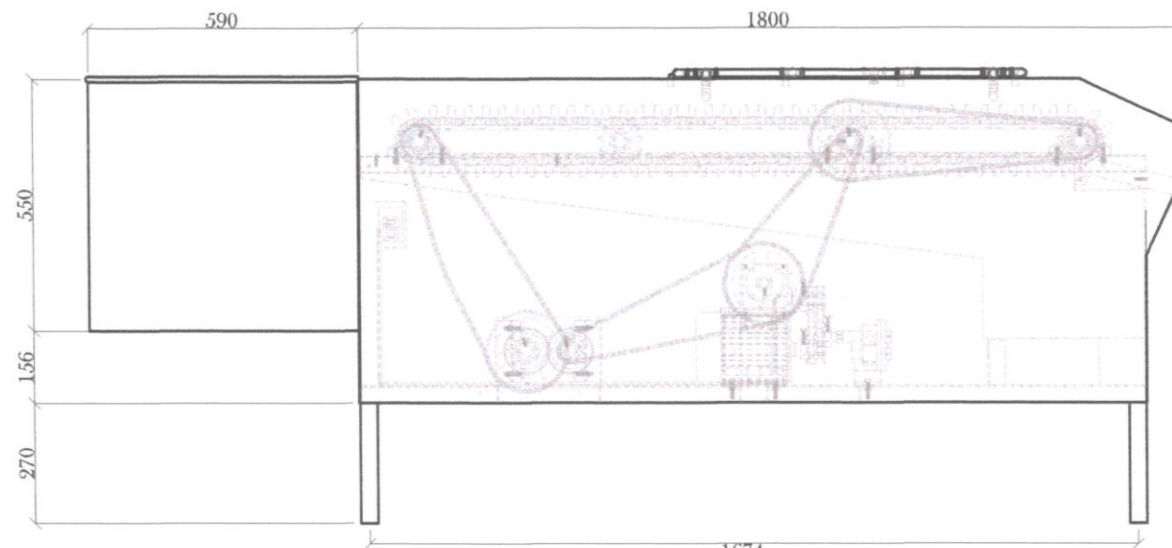

SIDE VIEW

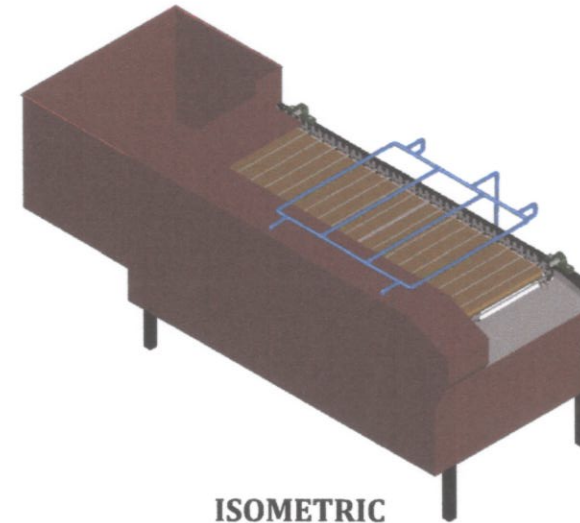

ISOMETRIC VIEW

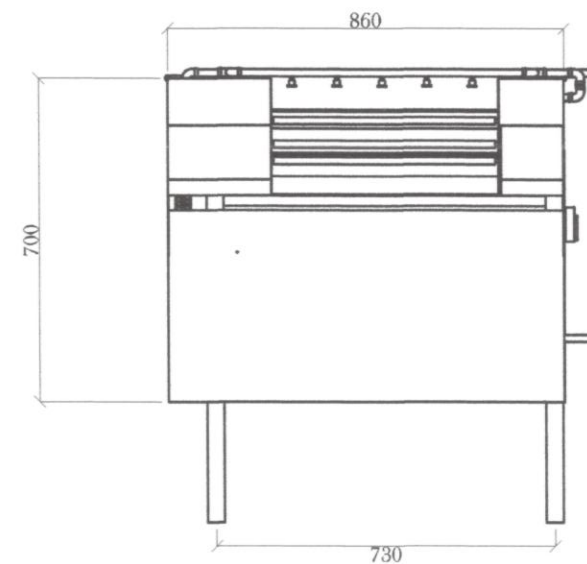

FRONT VIEW



COLLEGE OF ENGINEERING
Benguet State University
 La Trinidad, Benguet

Project: SPRINT-Hort Project 1 - Postharvest Systems Improvement of Selected Horticultural Value Chains

Funding Agency:
 Philippine Council for Agriculture, Aquatic and Natural Resources Research and Development (PCAARRD)

Implementing Agency:
 Benguet State University

Prepared by: 
LEONARDO D. DUMALHIN
 Project Leader

Scope of Work:
 Supply of Materials, Labor and Fabrication of Continuous Fed Carrot Washer Machine

Sheet Content

ORTHOGRAPHIC VIEW

Date:

Scale 1 : 15

Page No: $\frac{3}{5}$

Note: Design may vary depending on the result of pre testing

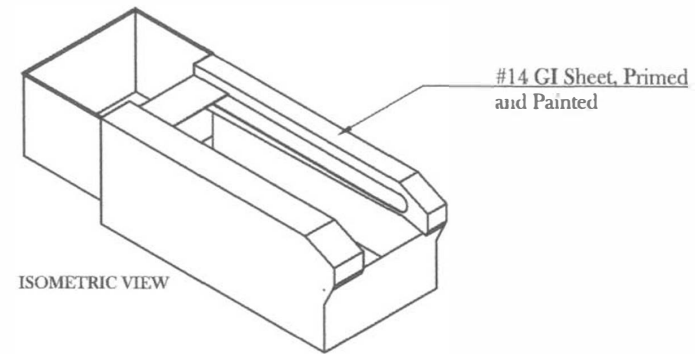
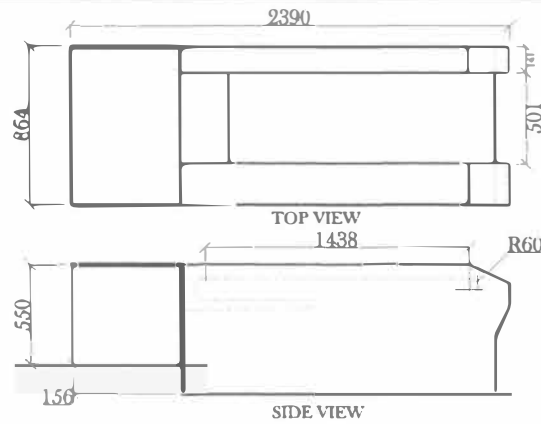

Body Cover Details
Scale..... 1:30

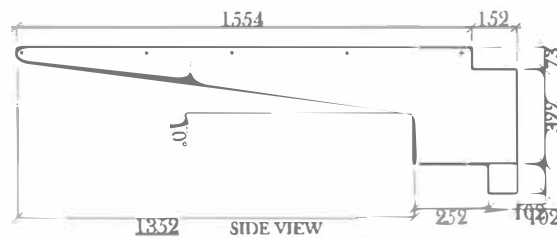
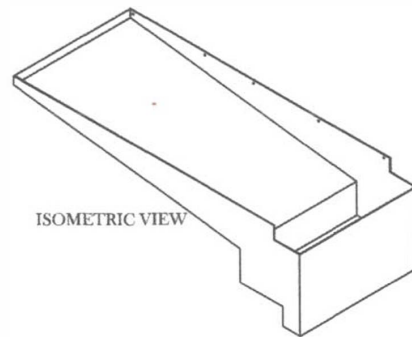
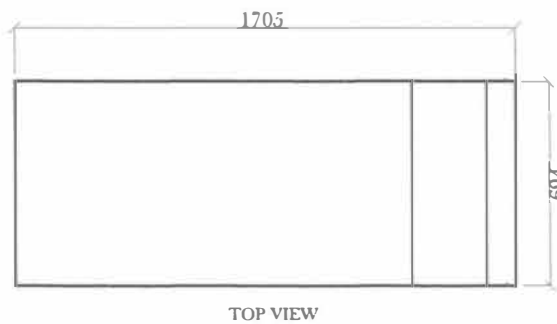

Water Collector Details
Scale..... 1:25

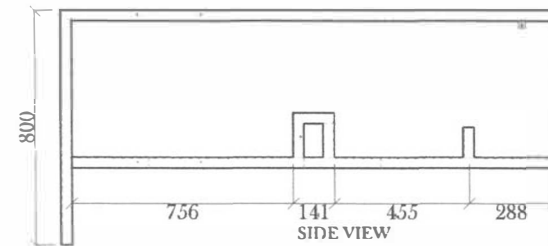
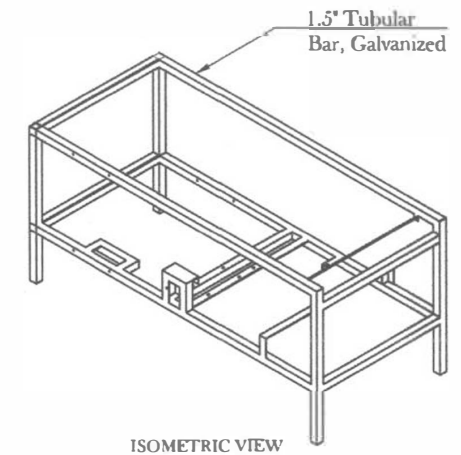
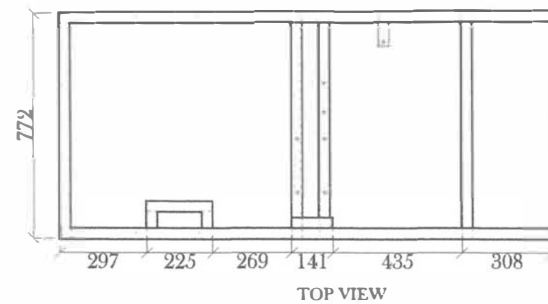

Body Frame Details
Scale..... 1:25

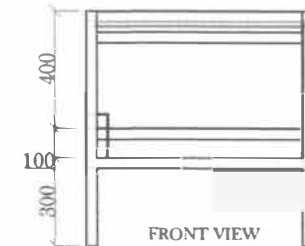

COLLEGE OF ENGINEERING
Benguet State University
La Trinidad, Benguet

Project: SPRINT-Hort Project 1 - Postharvest Systems Improvement of Selected Horticultural Value Chains

Funding Agency:
Philippine Council for Agriculture, Aquatic and Natural Resources Research and Development (PCAARRD)

Implementing Agency:
Benguet State University

Prepared by:
LEONARDO D. DUMALHIN
Project Leader

Scope of Work:
Supply of Materials, Labor and Fabrication of Continuous Fed Carrot Washer Machine

Sheet Content

AS SHOWN

Date:

Scale 1 : NTS

Page No:

4/5

Note: Design may vary depending on the result of pre testing
 For further details, please coordinate with to the end user

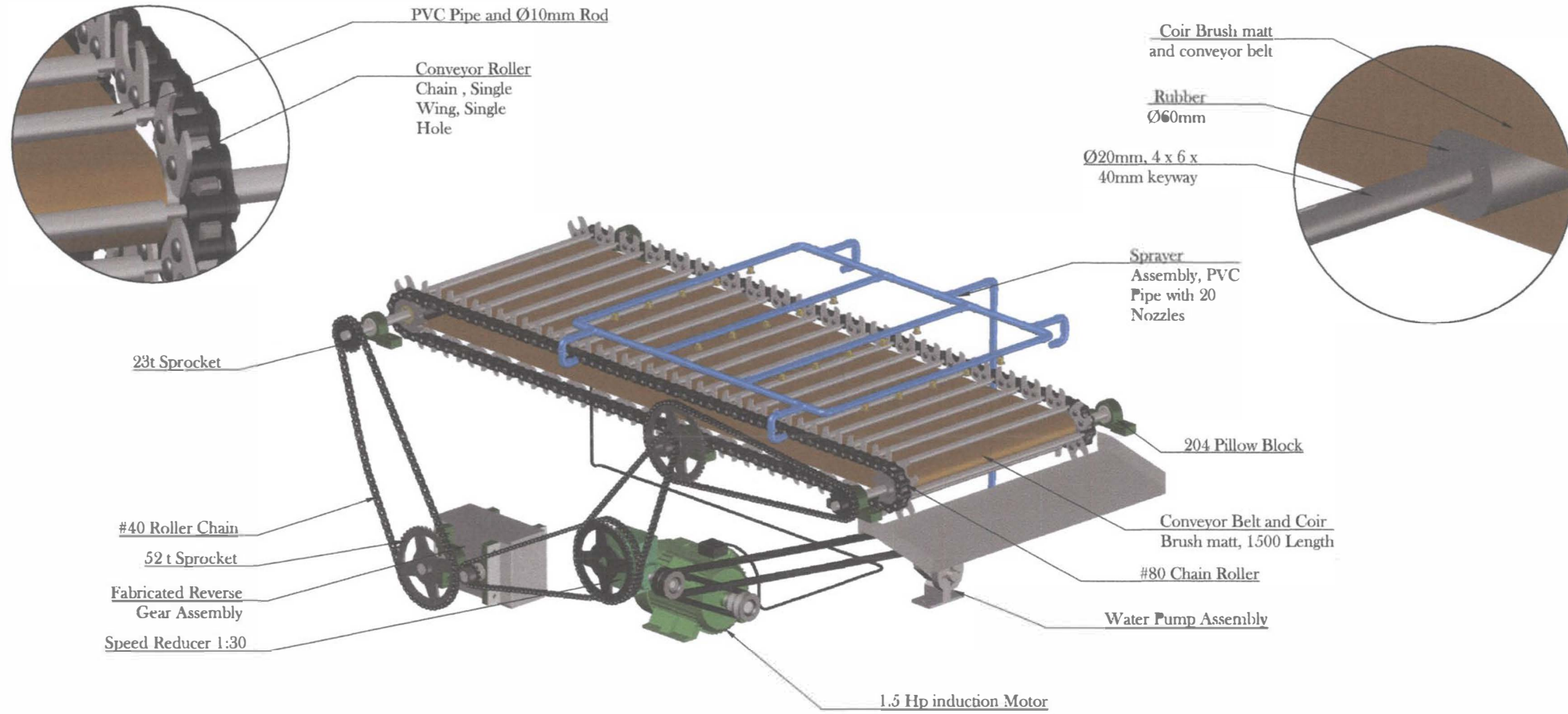

COLLEGE OF ENGINEERING
 Benguet State University
 La Trinidad, Benguet

Project: SPRINT-Hort Project 1 - Postharvest Systems Improvement of Selected Horticultural Value Chains

Funding Agency:
 Philippine Council for Agriculture, Aquatic and Natural Resources Research and Development (PCAARRD)

Implementing Agency:
 Benguet State University

Prepared by:
LEONARDO D. DUMALHIN
 Project Leader

Scope of Work:
 Supply of Materials, Labor and Fabrication of Continuous Fed Carrot Washer Machine

Sheet Content
Power Transmission Assembly Details

Date: _____
 Scale 1 : NTS
 Page No: $\frac{5}{5}$